

INSTALLATION MANUAL

R-22 OUTDOOR SPLIT-SYSTEM AIR CONDITIONING SHIPPED WITH NITROGEN CHARGE ONLY

MODELS: 13 SEER - GCGD
1.5 TO 5 TONS



LIST OF SECTIONS

GENERAL	1	EVACUATION	5
SAFETY	1	SYSTEM CHARGE	5
UNIT INSTALLATION	2	ELECTRICAL CONNECTIONS	6
ORIFICE INSTALLATION	4	INSTRUCTING THE OWNER	12
TXV INSTALLATIONS	5	Wiring Diagram	13

LIST OF FIGURES

Typical Installation	2	Typical Field Wiring (Air Handler / Electrical Heat)	7
Installation of Vapor Line	3	Thermostat Chart - Single Stage AC with PSC Air Handler	8
Underground Installation	3	Thermostat Chart - Single Stage AC with PSC Air Handler	9
Heat Protection	4	Thermostat Chart - Single Stage AC with PSC Furnace	10
Orifice Installation	5	Thermostat Chart - Single Stage AC with PSC Furnace	11
Outdoor Unit Control Box	7	Wiring Diagram	13

LIST OF TABLES

Application Limitations	2	R-22 Saturated Properties	6
-------------------------------	---	---------------------------------	---

SECTION I: GENERAL

The outdoor units are designed to be connected to a matching indoor coil with sweat connect lines. Sweat connect units have been shipped from the factor with a nitrogen holding charge.

The refrigerant charge may need to be changed for some indoor-outdoor unit combinations, elevation differences or total line lengths. Refer to Application Data covering "General Piping Recommendations and Refrigerant Line Length" (Part Number 247077).

CAUTION

This unit does not contain any refrigerant. It contains a nitrogen holding charge. Operating this unit with the nitrogen holding charge will damage the compressor.

IMPORTANT

Before operating this unit, vent the nitrogen and evacuate the entire system below 500 microns. Weigh in the refrigerant using the Tabular Data Sheet and Installation Manual.

SECTION II: SAFETY



This is a safety alert symbol. When you see this symbol on labels or in manuals, be alert to the potential for personal injury.

Understand and pay particular attention to the signal words **DANGER**, **WARNING**, or **CAUTION**.

DANGER indicates an **imminently** hazardous situation, which, if not avoided, **will result in death or serious injury**.

WARNING indicates a **potentially** hazardous situation, which, if not avoided, **could result in death or serious injury**.

CAUTION indicates a potentially hazardous situation, which, if not avoided **may result in minor or moderate injury**. It is also used to alert against unsafe practices and hazards involving only property damage.

WARNING

Improper installation may create a condition where the operation of the product could cause personal injury or property damage.

Improper installation, adjustment, alteration, service or maintenance can cause injury or property damage. Refer to this manual for assistance or for additional information, consult a qualified contractor, installer or service agency.

CAUTION

This product must be installed in strict compliance with the enclosed installation instructions and any applicable local, state, and national codes including, but not limited to building, electrical, and mechanical codes.

INSPECTION

As soon as a unit is received, it should be inspected for possible damage during transit. If damage is evident, the extent of the damage should be noted on the carrier's delivery receipt. A separate request for inspection by the carrier's agent should be made in writing. See Local Distributor for more information.

LIMITATIONS

The unit should be installed in accordance with all National, State and Local Safety Codes and the limitations listed below:

1. Limitations for the indoor unit, coil, and appropriate accessories must also be observed.
2. The outdoor unit must not be installed with any duct work in the air stream. The outdoor fan is the propeller type and is not designed to operate against any additional external static pressure.
3. The maximum and minimum conditions for operation must be observed to ensure a system that will give maximum performance with minimum service.

TABLE 1: Application Limitations

Ambient Air Temperature on Outdoor Coil		Air Temperature on Indoor Coil	
Min. DB	Max. DB	Min. WB	Max. WB
50 °F	115 °F	57 °F	72 °F

- The unit should not be operated at outdoor temperatures below 50° F without an approved low ambient operation accessory kit installed.
- The maximum allowable line length for this product is 75 feet.

SECTION III: UNIT INSTALLATION

LOCATION

Before starting the installation, select and check the suitability of the location for both the indoor and outdoor unit. Observe all limitations and clearance requirements.

The outdoor unit must have sufficient clearance for air entrance to the condenser coil, air discharge, and service access. See Figure 1.

NOTICE

For multiple unit installations, units must be spaced a minimum of 24 inches apart (coil face to coil face).

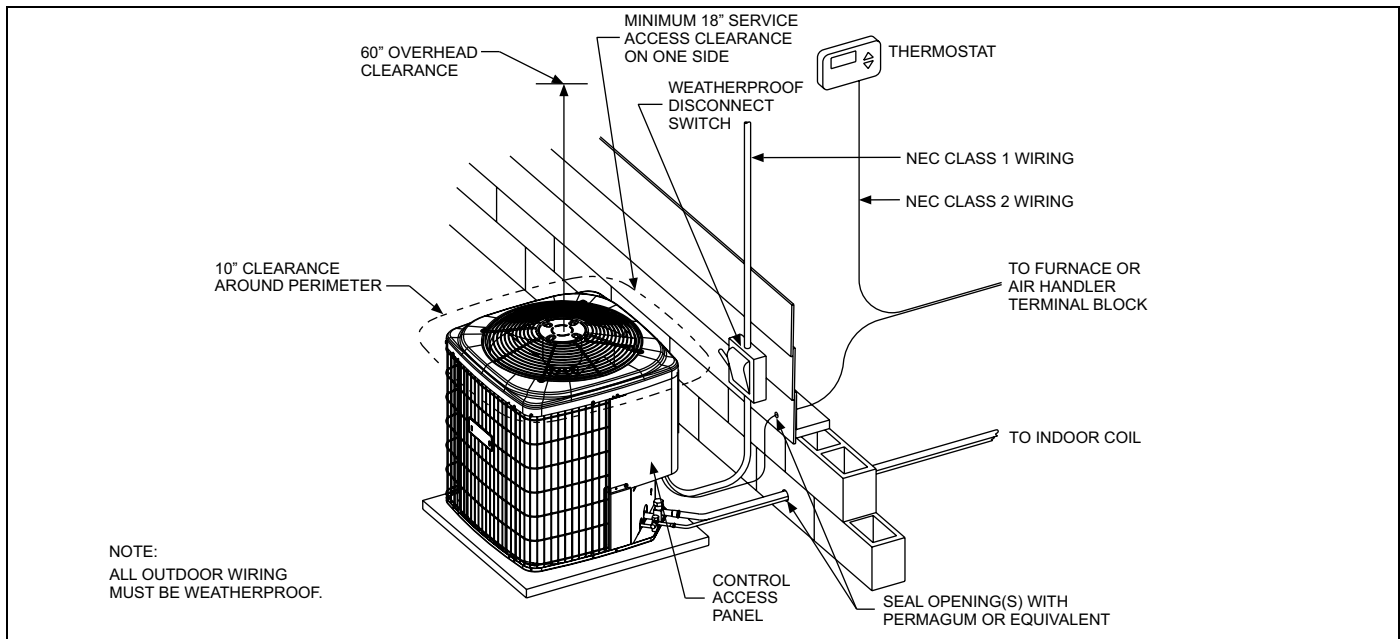

FIGURE 1: Typical Installation

GROUND INSTALLATION

The unit should be installed on a solid base that is 2" above grade and will not shift or settle, causing strain on the refrigerant lines and possible leaks. Maintain the clearances shown in Figure 1 and install the unit in a level position. The base pad should not come in contact with the foundation or side of the structure because sound may be transmitted to the residence.

The length of the refrigerant tubing between the outdoor unit and indoor coil should be as short as possible to avoid capacity and efficiency losses. Excessive spacing of the outdoor unit from the home can result in the refrigerant lines being restricted by trampling or being punctured by lawn mowers. Locate the outdoor unit away from bedroom windows or other rooms where sound might be objectionable.

If the unit is to be installed on a hot sun exposed roof or a black-topped ground area, the unit should be raised sufficiently above the roof or ground to avoid taking the accumulated layer of hot air into the outdoor unit.

Provide an adequate structural support.

ADD-ON REPLACEMENT/RETROFIT

The following steps should be performed in order to insure proper system operation and performance.

- Change-out the indoor coil, if required, to an approved R-22 coil/condensing unit combination with the appropriate metering device.
- If the outdoor unit is being replaced due to a compressor burnout, then installation of a 100% activated alumina suction-line filter drier in the suction-line is required, in addition to the factory installed liquid-line drier. Operate the system for 10 hours. Monitor the suction drier pressure drop. If the pressure drop exceeds 3 psig, replace both the suction-line and liquid-line driers. After a total of 10 hours run time where the suction-line pressure drop has not exceeded 3 psig, replace the liquid line drier, and remove the suction-line drier. Never leave a suction-line drier in the system longer than 50 hours of run time.

Adverse effects of snow or sleet accumulating on the outdoor coil can be eliminated by placing the outdoor unit where the prevailing wind does not blow across the unit. Trees, shrubs, corners of buildings, and fences standing off from the coil can reduce capacity loss due to wind chill effect.

Provide ample clearance from shrubs to allow adequate air to pass across the outdoor coil without leaves or branches being pulled into the coil.

ROOF INSTALLATION

When installing units on a roof, the structure must be capable of supporting the total weight of the unit, including a pad, lintels, rails, etc., which should be used to minimize the transmission of sound or vibration into the conditioned space.

LIQUID LINE FILTER-DRIER

The air conditioning unit's copper spun filter/dryer is located on the liquid line.

NOTICE

Replacements for the liquid line drier *must be exactly the same as marked on the original factory drier. See Source 1 for O.E.M. replacement driers.*

CAUTION

Failure to do so or using a substitute drier or a granular type may result in damage to the equipment.

Filter-Drier Source 1 Part No.	Apply with Models
S1-02922156000	1.5 to 3 Tons
S1-02922157000	3.5 to 5 Tons

PIPING CONNECTIONS

The outdoor condensing unit must be connected to the indoor evaporator coil using field supplied refrigerant grade (ACR) copper tubing that is internally clean and dry. Units should be installed only with the tubing sizes for approved system combinations as specified in tabular data sheet. The charge given is applicable for total tubing lengths up to 15 feet. See Application Data Part Number 247077 for installing tubing of longer lengths and elevation differences.

NOTICE

Using a larger than specified line size could result in oil return problems. Using too small a line will result in loss of capacity and other problems caused by insufficient refrigerant flow. Slope horizontal vapor lines at least 1" every 20 feet toward the outdoor unit to facilitate proper oil return.

PRECAUTIONS DURING LINE INSTALLATION

1. Install the lines with as few bends as possible. Care must be taken not to damage the couplings or kink the tubing. Use clean hard drawn copper tubing where no appreciable amount of bending around obstruction is necessary. If soft copper must be used, care must be taken to avoid sharp bends which may cause a restriction.
2. The lines should be installed so that they will not obstruct service access to the coil, air handling system, or filter.
3. Care must also be taken to isolate the refrigerant lines to minimize noise transmission from the equipment to the structure.
4. The vapor line must be insulated with a minimum of 1/2" foam rubber insulation (Armaflex or equivalent). Liquid lines that will be exposed to direct sunlight, high temperatures, or excessive humidity must also be insulated.
5. Tape and suspend the refrigerant lines as shown. DO NOT allow tube metal-to-metal contact. See Figure 2.
6. Use PVC piping as a conduit for all underground installations as shown in Figure 3. Buried lines should be kept as short as possible to minimize the build up of liquid refrigerant in the vapor line during long periods of shutdown
7. Pack fiberglass insulation and a sealing material such as perma-gum around refrigerant lines where they penetrate a wall to reduce vibration and to retain some flexibility.
8. For systems with total line length exceeding 50 feet, see APPLICATION DATA and worksheet "General Piping Recommendations and Refrigerant Line Length" for vapor and liquid line sizing, calibration of liquid line pressure loss or gain, determination of vapor line velocity, elevation limitations, orifice connections, system charging, traps, etc.

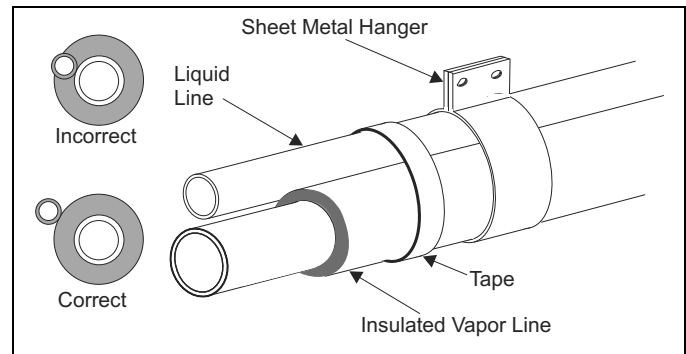

FIGURE 2: Installation of Vapor Line

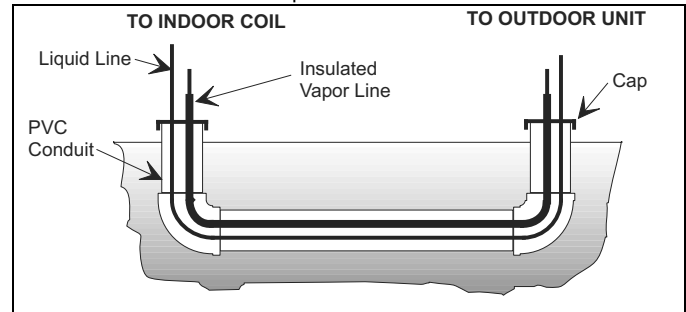

FIGURE 3: Underground Installation

PRECAUTIONS DURING BRAZING OF LINES

All outdoor unit and evaporator coil connections are copper-to-copper and should be brazed with a phosphorous-copper alloy material such as Silfos-5 or equivalent. DO NOT use soft solder. The outdoor units have reusable service valves on both the liquid and vapor connections. Units are shipped from factory with a nitrogen holding charge. Refer to Tabular Data Sheet for refrigerant charge quantities. Reusable service valves are provided to evacuate and charge per this instruction.

Serious service problems can be avoided by taking adequate precautions to assure an internally clean and dry system.

CAUTION

Dry nitrogen should always be supplied through the tubing while it is being brazed, because the temperature required is high enough to cause oxidation of the copper unless an inert atmosphere is provided. The flow of dry nitrogen should continue until the joint has cooled. Always use a pressure regulator and safety valve to insure that only low pressure dry nitrogen is introduced into the tubing. Only a small flow is necessary to displace air and prevent oxidation.

PRECAUTIONS DURING BRAZING SERVICE VALVE

Precautions should be taken to prevent heat damage to service valve by wrapping a wet rag around it as shown in Figure 4. Also, protect all painted surfaces, insulation, and plastic base during brazing. After brazing, cool joint with wet rag.

WARNING

This is not a backseating valve. The service access port has a valve core. Opening or closing valve does not close service access port. If the valve stem is backed out past the chamfered retaining wall, the O-ring can be damaged causing leakage or system pressure could force the valve stem out of the valve body possibly causing personal injury.

Valve can be opened by removing the plunger cap and fully inserting a hex wrench into the stem and backing out counter-clockwise until valve stem just touches the chamfered retaining wall.

Connect the refrigerant lines using the following procedure:

1. Remove the cap and Schrader core from both the liquid and vapor service valve service ports at the outdoor unit. Connect low pressure nitrogen to the liquid line service port.
2. Braze the liquid line to the liquid valve at the outdoor unit. Be sure to wrap the valve body with a wet rag. Allow the nitrogen to continue flowing.
3. Carefully remove the plugs from the evaporator liquid and vapor connections at the indoor coil.

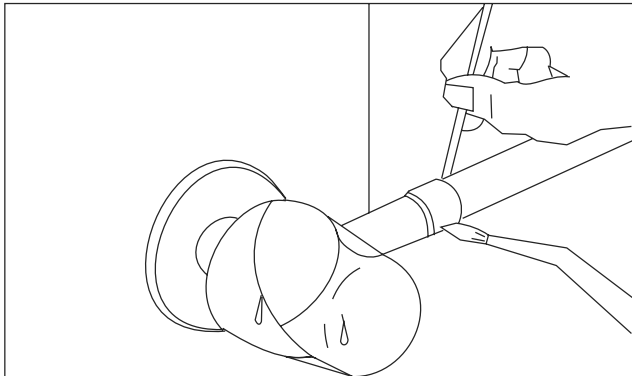

FIGURE 4: Heat Protection

CAUTION

Do not install any coil in a furnace which is to be operated during the heating season without attaching the refrigerant lines to the coil. The coil is under 30 to 35 psig inert gas pressure which must be released to prevent excessive pressure build-up and possible coil damage.

4. Braze the liquid line to the evaporator liquid connection. Nitrogen should be flowing through the evaporator coil.
5. Slide the grommet away from the vapor connection at the indoor coil. Braze the vapor line to the evaporator vapor connection. After the connection has cooled, slide the grommet back into original position.
6. Protect the vapor valve with a wet rag and braze the vapor line connection to the outdoor unit. The nitrogen flow should be exiting the system from the vapor service port connection. After this connection has cooled, remove the nitrogen source from the liquid fitting service port.
7. Vent the nitrogen holding charge in the outdoor unit by opening both service valves slowly and waiting for the pressure to dissipate. Open both the liquid and vapor valves by removing the plunger cap and with an allen wrench back out counter-clockwise until valve stem just touches the chamfered retaining wall. If the service valve is a ball valve, use a crescent wrench to turn valve stem one-quarter turn counterclockwise to open. Do not overturn or the valve stem may break or become damaged. See "PRECAUTIONS DURING BRAZING SERVICE VALVE".
8. Replace the Schrader core in the liquid and vapor valves.
9. Go to "SECTION V" or "SECTION IV" for orifice or TXV installation depending on application.
10. Leak test all refrigerant piping connections including the service port flare caps to be sure they are leak tight. DO NOT OVERTIGHTEN (between 40 and 60 inch - lbs. maximum).

NOTICE

Line set and indoor coil can be pressurized to 250 psig with dry nitrogen and leak tested with a bubble type leak detector. Then release the nitrogen charge.

11. Evacuate the vapor line, evaporator, and liquid line to 500 microns or less.
12. Replace cap on service ports. Do not remove the flare caps from the service ports except when necessary for servicing the system.

CAUTION

Do not connect manifold gauges unless trouble is suspected. Approximately 3/4 ounce of refrigerant will be lost each time a standard manifold gauge is connected.

13. Release the refrigerant charge into the system since these units have been shipped from the factory with a nitrogen holding charge.
14. Replace plunger cap finger tight, then tighten an additional 1/12 turn (1/2 hex flat). Cap must be replaced to prevent leaks.

WARNING

Never attempt to repair any brazed connections while the system is under pressure. Personal injury could result.

See "System Charge" section for checking and recording system charge.

Supplied with the outdoor unit is a Schrader Valve Core and Orifice for highest sales volume indoor coil. The valve core must be installed in equalizer fitting of the indoor coil.

SECTION IV: ORIFICE INSTALLATION

WARNING

Failure to install Schrader Valve Core on orifice applications could result in total refrigerant loss of the system!

Install Schrader Valve Core as follows:

1. Slide indoor coil out of cabinet far enough to gain access to equalizer fitting on the suction line.
2. After holding charge is completely discharged remove black plastic cap on equalizer fitting.
3. Install Schrader Valve Core supplied with the outdoor unit into equalizer fitting using a valve core tool.
4. Loosen and remove the liquid line fitting from the orifice distributor assembly. Note that the fitting has right hand threads.
5. Install proper size orifice supplied with outdoor unit. Refer to supplied Tabular Data Sheet for specific orifice size and indoor coil match up.
6. After orifice is installed reinstall the liquid line to the top of the orifice distributor assembly. Hand tighten and turn an additional 1/8 turn to seal. Do not over tighten fittings.
7. Leak test system.
8. Replace black plastic cap on equalizer fitting.
9. Slide indoor coil back into cabinet.

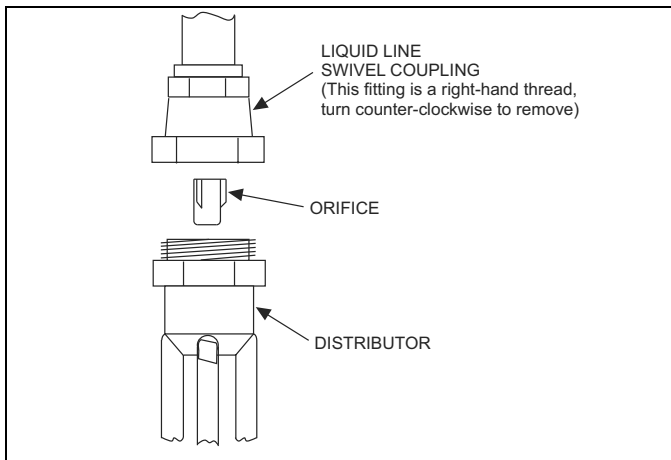

FIGURE 5: Orifice Installation

SECTION V: TXV INSTALLATIONS

CAUTION

When using a TXV, models 18-48 require a hard start kit.

The following are the basic steps for installation. For detailed instructions, refer to the Installation Instructions accompanying the TXV kit. Install TXV kit as follows:

1. Relieve the holding charge by pulling off the rubber cap plug on the suction manifold line of the coil.
2. After holding charge is completely discharged, loosen and remove the schraeder cap seal.
3. Loosen and remove distributor cap seal.
4. Install the thermal expansion valve to the orifice distributor assembly with supplied fittings. Hand tighten and turn an additional 1/4 turn to seal. Do not overtighten fittings.
5. Install the liquid line to the top of the thermal expansion valve with fitting supplied with the liquid line. Hand modify the liquid line to align with casing opening. Hand tighten the liquid line and an additional 1/4 turn to seal.
6. Install the TXV equalizer line into the vapor line as follows:
 - a. Hand tighten the 1/4" SAE nut to the schraeder fitting and an additional 1/3 turn to seal.
7. Install the TXV bulb to the vapor line near the equalizer line, using the bulb clamp(s) furnished with the TXV assembly. Ensure the bulb is making maximum contact.
 - a. Bulb should be installed on a horizontal run of the vapor line if possible. The bulb should be installed on top of the line.
 - b. If bulb installation is made on a vertical run, the bulb should be located at least 16 inches from any bend, and on the tubing sides opposite the plane of the bend. The bulb should be positioned with the bulb tail at the top, so that the bulb acts as a reservoir.
 - c. Bulb should be insulated using thermal insulation provided to protect it from the effect of the surrounding ambient temperature. Cover completely to insulate from air-stream.

CAUTION

In all cases, mount the TXV bulb after vapor line is brazed and has had sufficient time to cool.

WARNING

Schraeder valve core **MUST NOT** be installed with TXV installation. Poor system performance or system failure could result.

SECTION VI: EVACUATION

It will be necessary to evacuate the system to 500 microns or less. If a leak is suspected, leak test with dry nitrogen to locate the leak. Repair the leak and test again.

To verify that the system has no leaks, simply close the valve to the vacuum pump suction to isolate the pump and hold the system under vacuum. Watch the micron gauge for a few minutes. If the micron gauge indicates a steady and continuous rise, it's an indication of a leak. If the gauge shows a rise, then levels off after a few minutes and remains fairly constant, it's an indication that the system is leak free but still contains moisture and may require further evacuation if the reading is above 500 microns.

SECTION VII: SYSTEM CHARGE

See tabular data sheet provided in unit literature packet for charge requirements. These units have been shipped from factory with a nitrogen holding charge.

CAUTION

This unit does not contain any refrigerant. It contains a nitrogen holding charge. Operating this unit with the nitrogen holding charge will damage the compressor.

CAUTION

Do not leave the system open to the atmosphere.

The "TOTAL SYSTEM CHARGE" must be permanently stamped on the unit data plate.

Total system charge is determined as follows:

1. Determine initial unit charge from tabular data sheet.
2. Calculate the line charge using the tabular data sheet if line length is greater than 15 feet.
3. Total system charge = item 1 + item 2.
4. Permanently stamp the unit data plate with the total amount of refrigerant in the system.

Use the following charging method whenever additional refrigerant is required for the system charge.

WARNING

DO NOT attempt to pump "Total System Charge" into outdoor unit for maintenance, service, etc. This may cause damage to the compressor and/or other components. The outdoor unit only has enough volume for the factory charge, not the "Total System Charge".

CAUTION

Refrigerant charging should only be carried out by a qualified air conditioning contractor.

CAUTION

Compressor damage will occur if system is improperly charged. On new system installations, charge system per tabular data sheet for the matched coil and follow guidelines in this instruction.

If a calibrated charging cylinder or accurate weighing device is available, add refrigerant accordingly. Otherwise, model-specific charging charts are provided on the access panel of the unit.

SUPERHEAT CHARGING METHOD - PISTON INDOOR

1. Operate system until temperatures and pressures stabilize (minimum of 10 minutes).
2. Measure and record indoor wet bulb (WB) temperature using a sling psychrometer and the outdoor dry bulb (DB) temperature using a thermometer.
3. Measure and record the suction pressure at the suction service valve port.
4. Using charts located on the unit, note the superheat value corresponding to the intersection of the indoor wet bulb and the outdoor dry bulb.
5. With the superheat value obtained in step 4 and the suction pressure value from step 3, find the intersection of the values on the chart. This is the required suction tube temperature at the suction service valve.
6. To bring the tube temperature in line with the required value from chart, add refrigerant to the service port to cause the tube temperature to fall and reclaim refrigerant to cause the temperature to rise.

SUBCOOLING CHARGING METHOD - TXV INDOOR

The recommended subcooling is 10°F

1. Set the system running in the cooling mode by setting the thermostat at least 6°F below the room temperature.
2. Operate the system for a minimum of 15-20 minutes.
3. Refer to the tabular data sheet for the recommended airflow and verify this indoor airflow (it should be about 400 SCFM per ton).
4. Measure the liquid refrigerant pressure P and temperature T at the service valve.
5. Calculate the saturated liquid temperature ST from Table 2.
6. Subcooling temperature TC = Saturated Temperature (ST) - Liquid Temp (T).

Example: The pressure P and temperature T measured at the liquid service port is 196 psig and 90°F, respectively. From Table 2, the saturated temperature for 196 psig is 100°F. The subcooling temperature TC = 100°-90°=10°F

Add charge if the calculated subcooling temperature TC in Step 6 is lower than the recommended level. Remove and recover the refrigerant if the subcooling TC is higher than the recommended level. See Table 2.

Check flare caps on service ports to be sure they are leak tight. DO NOT OVERTIGHTEN (between 40 and 60 inch - lbs. maximum).

TABLE 2: R-22 Saturated Properties

Pressure PSIG	Temp °F	Pressure PSIG	Temp °F	Pressure PSIG	Temp °F	Pressure PSIG	Temp °F	Pressure PSIG	Temp °F	Pressure PSIG	Temp °F
80	48	110	64	140	78	170	91	200	101	230	111
82	49	112	65	142	79	172	91	202	102	232	112
84	50	114	66	144	80	174	92	204	103	234	112
86	51	116	67	146	81	176	93	206	103	236	113
88	52	118	68	148	82	178	94	208	104	238	114
90	54	120	69	150	83	180	94	210	105	240	114
92	55	122	70	152	84	182	95	212	105	242	115
94	56	124	71	154	84	184	96	214	106	244	115
96	57	126	72	156	85	186	97	216	107	246	116
98	58	128	73	158	86	188	97	218	107	248	117
100	59	130	74	160	87	190	98	220	108	250	117
102	60	132	75	162	88	192	99	222	109	252	118
104	61	134	76	164	88	194	99	224	109	254	118
106	62	136	77	166	89	196	100	226	110	256	119
108	63	138	78	168	90	198	101	228	111	258	119

CAUTION

IT IS UNLAWFUL TO KNOWINGLY VENT, RELEASE OR DISCHARGE REFRIGERANT INTO THE OPEN AIR DURING REPAIR, SERVICE, MAINTENANCE OR THE FINAL DISPOSAL OF THIS UNIT.

WHEN THE SYSTEM IS FUNCTIONING PROPERLY AND THE OWNER HAS BEEN FULLY INSTRUCTED, SECURE THE OWNER'S APPROVAL.

CAUTION

All field wiring must USE COPPER CONDUCTORS ONLY and be in accordance with Local, National, Fire, Safety & Electrical Codes. This unit must be grounded with a separate ground wire in accordance with the above codes.

The complete connection diagram and schematic wiring label is located on the inside surface of the unit service access panel.

SECTION VIII: ELECTRICAL CONNECTIONS

GENERAL INFORMATION & GROUNDING

Check the electrical supply to be sure that it meets the values specified on the unit nameplate and wiring label.

Power wiring, control (low voltage) wiring, disconnect switches and over current protection must be supplied by the installer. Wire size should be sized per NEC requirements.

FIELD CONNECTIONS POWER WIRING

1. Install the proper size weatherproof disconnect switch outdoors and within sight of the unit.
2. Remove the screws at the top and sides of the corner cover. Slide corner cover down and remove from unit.
3. Run power wiring from the disconnect switch to the unit.
4. Route wires from disconnect through power wiring opening provided and into the unit control box as shown in Figure 6.
5. Install the proper size time-delay fuses or circuit breaker, and make the power supply connections.

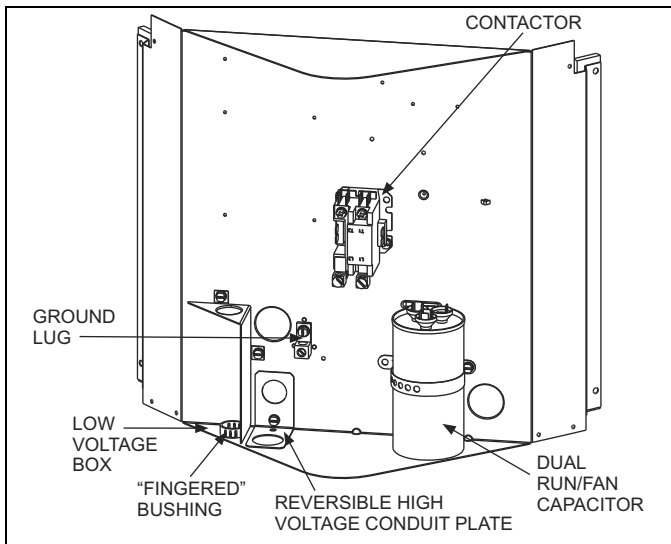

FIGURE 6: Outdoor Unit Control Box

FIELD CONNECTIONS CONTROL WIRING

1. Route low voltage wiring into bottom of control box as shown in Figure 6. Make low voltage wiring connections inside the low voltage box per Figures 7 - 11.
2. The complete connection diagram and schematic wiring label is located on the inside surface of the unit service access panel.
3. Replace the corner cover removed in Step 2.
4. All field wiring to be in accordance with national electrical codes (NEC) and/or local-city codes.

NOTICE

A Start Assist Kit is available and recommended for long line set applications or in areas of known low voltage problems.

5. Mount the thermostat about 5 ft. above the floor, where it will be exposed to normal room air circulation. Do not place it on an outside wall or where it is exposed to the radiant effect from exposed glass or appliances, drafts from outside doors or supply air grilles.
6. Route the 24-volt control wiring (NEC Class 2) from the outdoor unit to the indoor unit and thermostat.

NOTICE

To eliminate erratic operation, seal the hole in the wall at the thermostat with permagum or equivalent to prevent air drafts affecting the operation of in the thermostat.

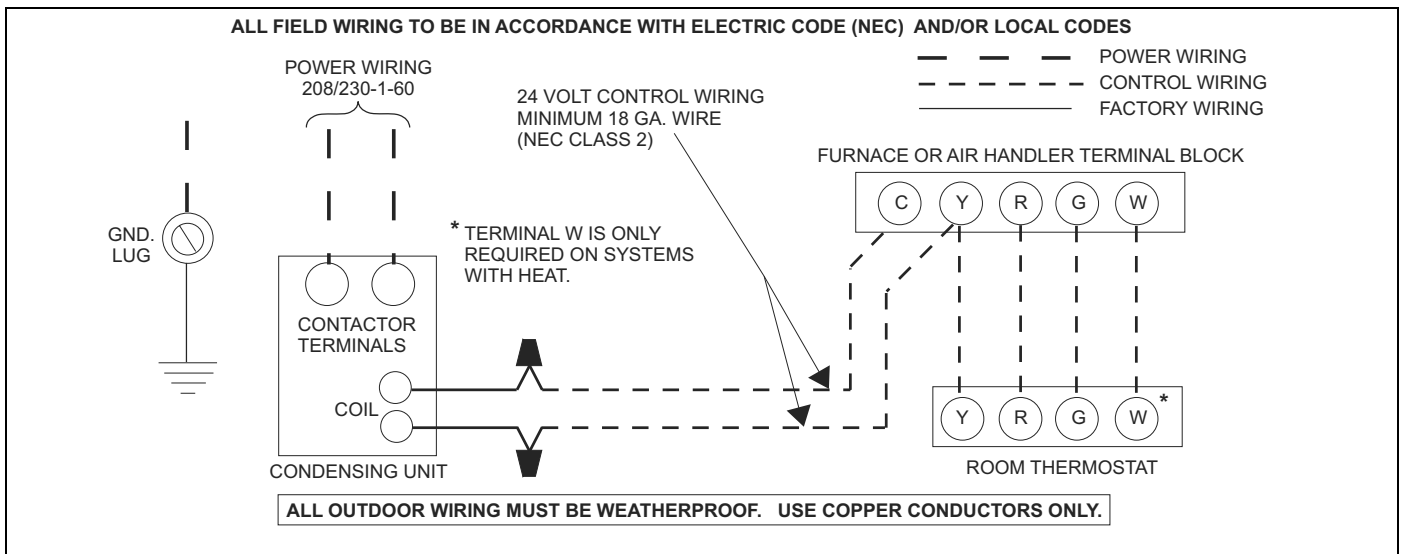

FIGURE 7: Typical Field Wiring (Air Handler / Electrical Heat)

AC 1B Single Stage Air Conditioner – PSC Air Handler

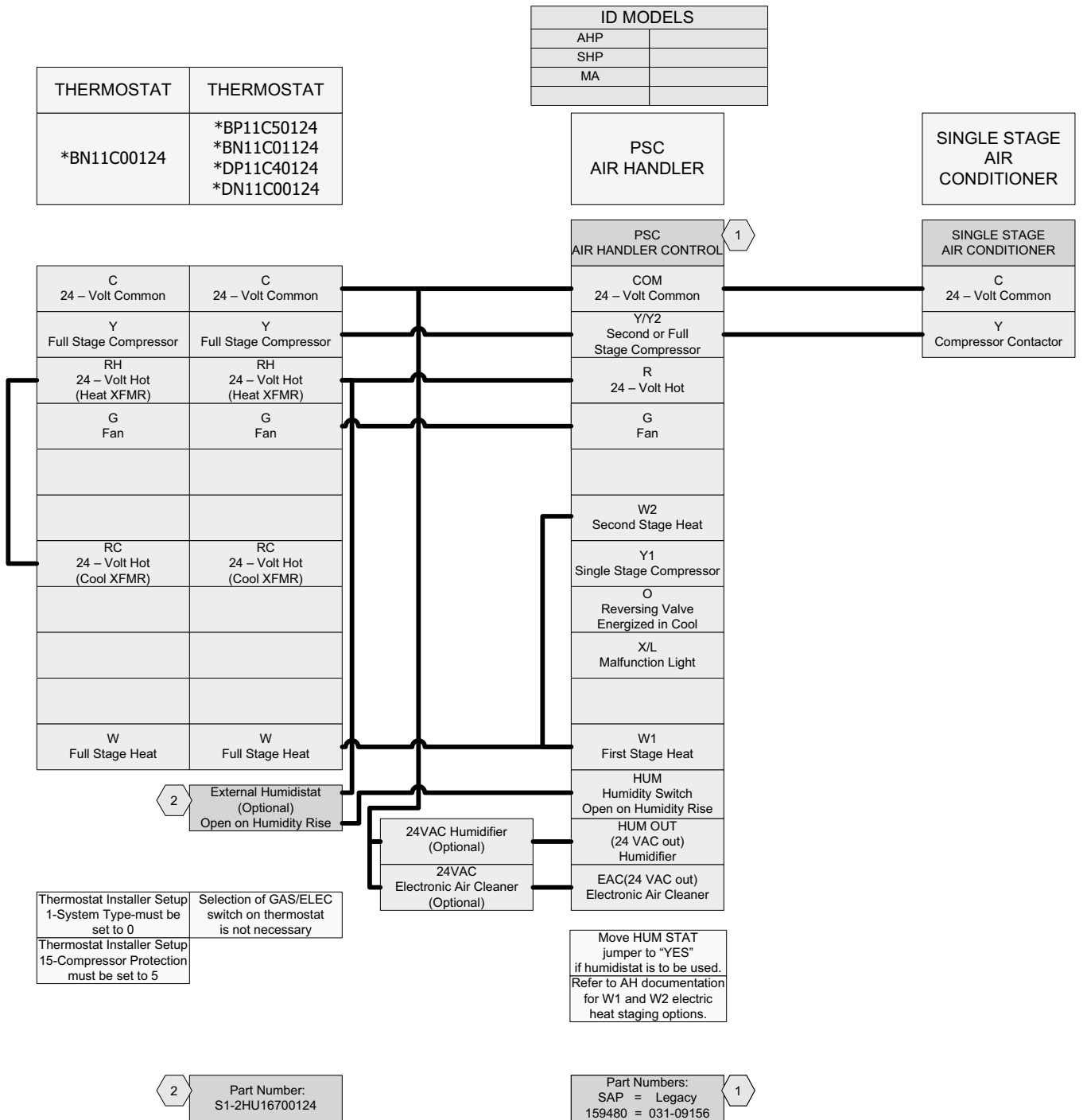

FIGURE 9: Thermostat Chart - Single Stage AC with PSC Air Handler

AC 5A Single Stage Air Conditioner – Single Stage PSC Furnace

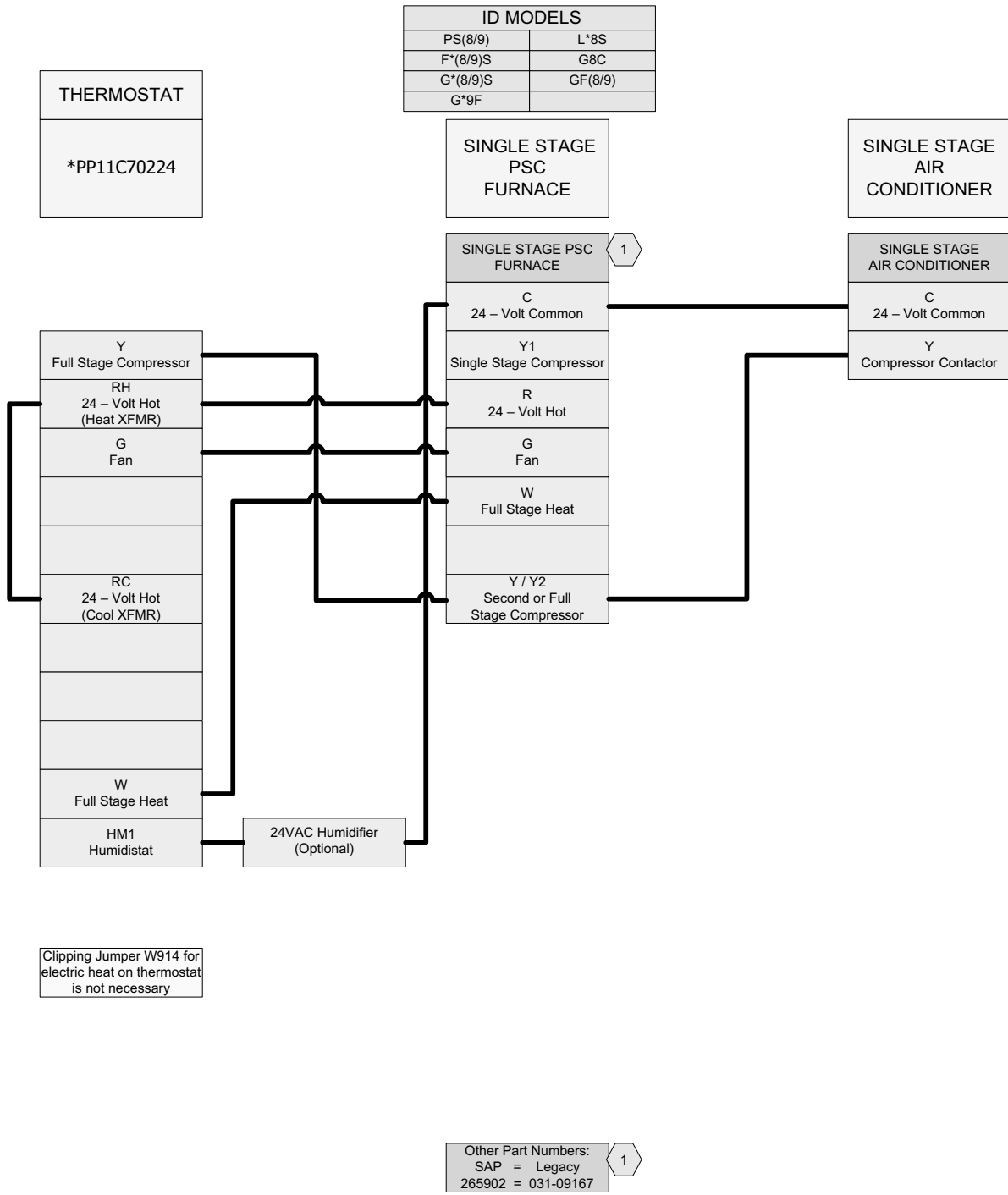

FIGURE 10: Thermostat Chart - Single Stage AC with PSC Furnace

AC 5B

Single Stage Air Conditioner – Single Stage PSC Furnace

THERMOSTAT	THERMOSTAT
*BN11C00124	*BP11C50124 *BN11C01124 *DP11C40124 *DN11C00124

ID MODELS	
PS(8/9)	L*8S
F*(8/9)S	G8C
G*(8/9)S	GF(8/9)
G*9F	

SINGLE STAGE PSC FURNACE

SINGLE STAGE AIR CONDITIONER

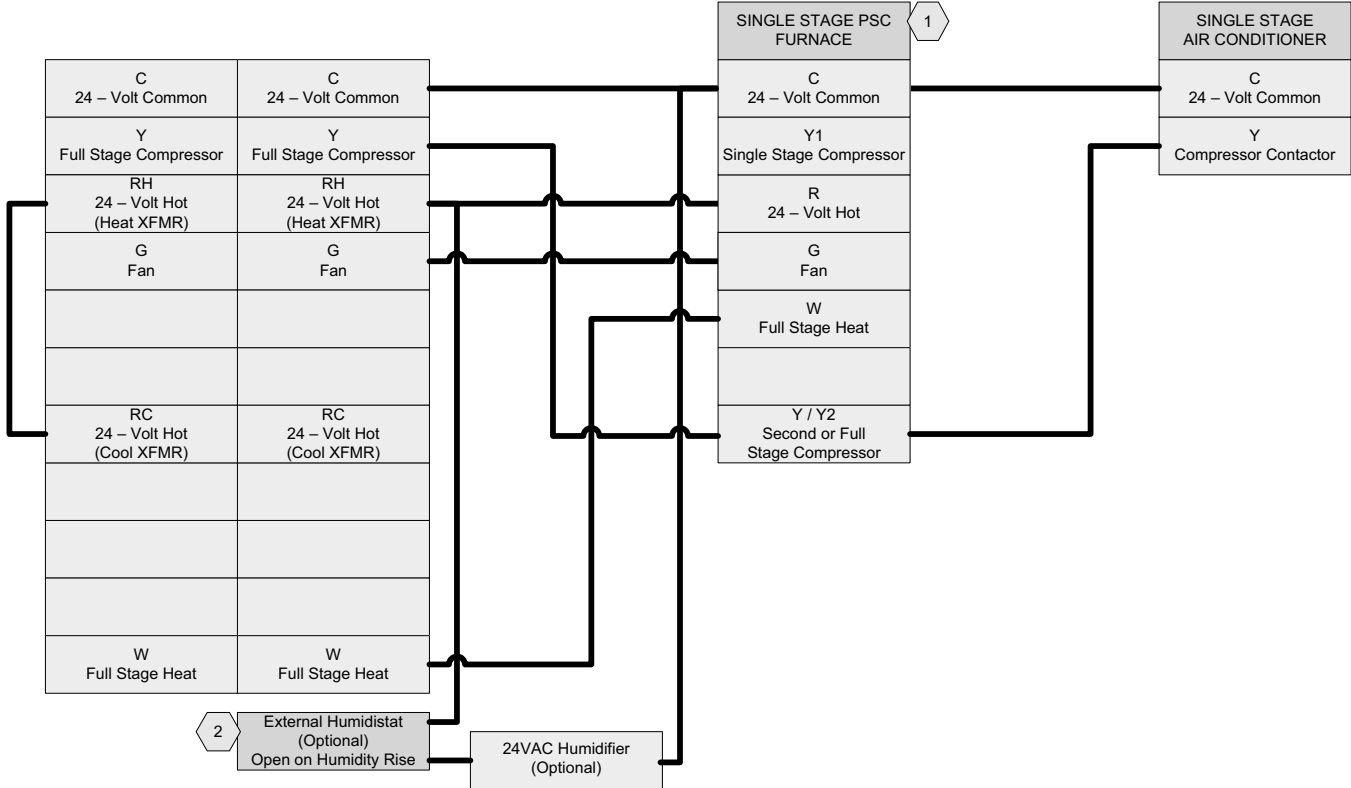

Thermostat Installer Setup 1-System Type-must be set to 0	Selection of GAS/ELEC switch on thermostat is not necessary
Thermostat Installer Setup 15-Compressor Protection must be set to 5	

2 Part Number: S1-2HU16700124

Other Part Numbers:
SAP = Legacy
265902 = 031-09167 1

FIGURE 11: Thermostat Chart - Single Stage AC with PSC Furnace

SECTION IX: INSTRUCTING THE OWNER

Assist owner with processing warranty cards and/or online registration. Review Owners Guide and provide a copy to the owner and guidance on proper operation and maintenance. Instruct the owner or the operator how to start, stop and adjust temperature setting.

When applicable, instruct the owner that the compressor is equipped with a crankcase heater to prevent the migration of refrigerant to the compressor during the "OFF" cycle. The heater is energized only when the unit is not running. If the main switch is disconnected for long periods of shut down, do not attempt to start the unit until 8 hours after the switch has been connected. This will allow sufficient time for all liquid refrigerant to be driven out of the compressor.

The installer should also instruct the owner on proper operation and maintenance of all other system components.

MAINTENANCE

1. Dirt should not be allowed to accumulate on the outdoor coils or other parts in the air circuit. Clean as often as necessary to keep the unit clean. Use a brush, vacuum cleaner attachment, or other suitable means.

2. The outdoor fan motor is permanently lubricated and does not require periodic oiling.
3. If the coil needs to be cleaned, use clean water to wash dust, dirt, and debris from outdoor condensing coil.

NOTICE

DO NOT use coil cleaners to clean outdoor condensing coil. Cleaners containing HF-, hydroxides, chlorides, and sulfates can greatly reduce the lifetime of the aluminum condensing coil.

4. Refer to the furnace or air handler instructions for filter and blower motor maintenance.
5. The indoor coil and drain pan should be inspected and cleaned regularly to prevent odors and assure proper drainage.

CAUTION

IT IS UNLAWFUL TO KNOWINGLY VENT, RELEASE OR DISCHARGE REFRIGERANT INTO THE OPEN AIR DURING REPAIR, SERVICE, MAINTENANCE OR THE FINAL DISPOSAL OF THIS UNIT.

WHEN THE SYSTEM IS FUNCTIONING PROPERLY AND THE OWNER HAS BEEN FULLY INSTRUCTED, SECURE THE OWNER'S APPROVAL.

SECTION X: WIRING DIAGRAM

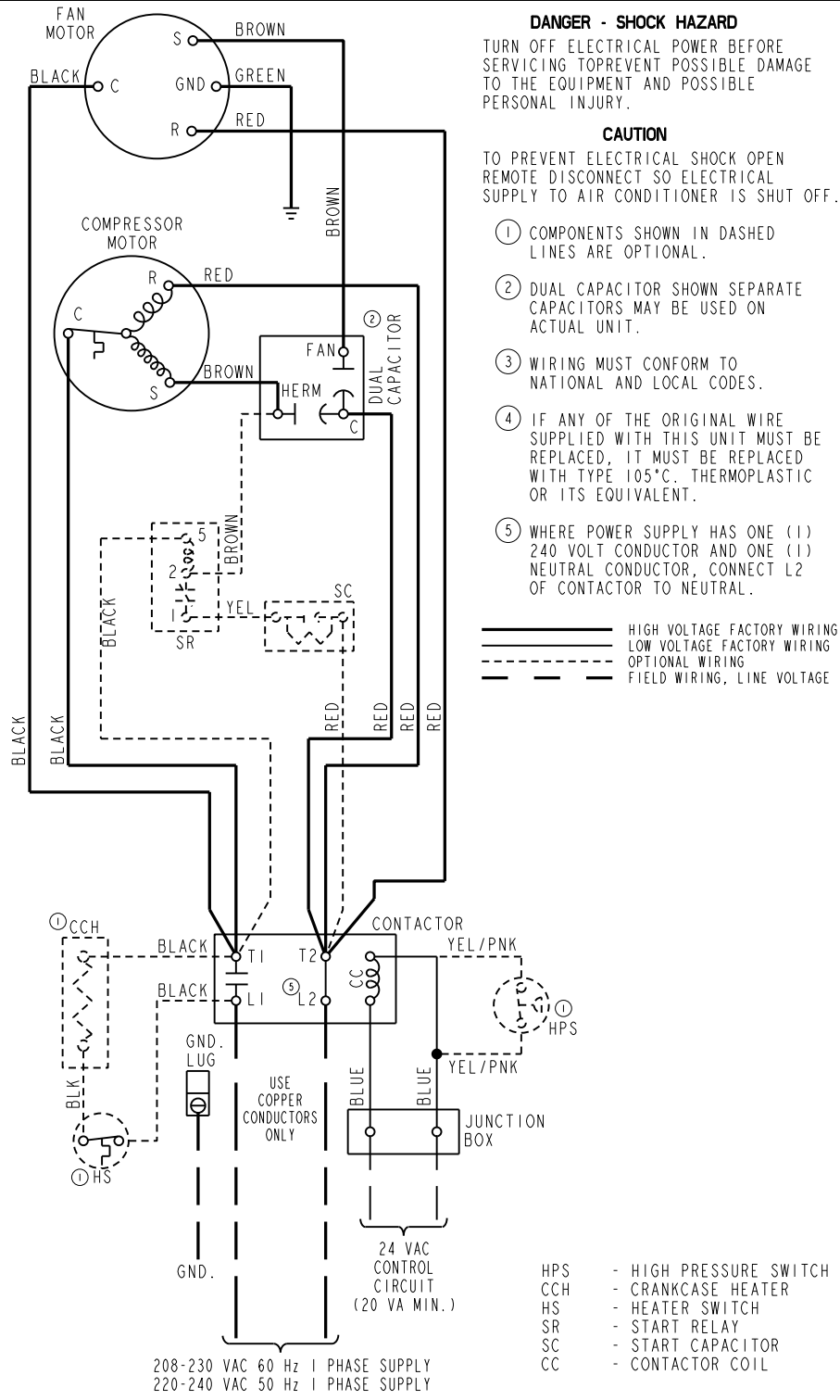

167242-UWD-D-1009

FIGURE 12: Wiring Diagram

NOTES
