

Spirit series^{by}

Thermo Products, LLC

OIL FIRED UPFLOW FURNACE SPECIFICATIONS

MODEL NO.	VH8FA119P60B VH8FA119T60B (BECKETT AFG)		
HEATING CAPACITY	High Fire	* Med Fire	Low Fire
HEAT INPUT RATE (BTUH)	156,250	140,000	119,000
OUTPUT BTUH ¹	132,000	119,000	101,000
SEASONAL EFFICIENCY ²	* 85.0%		
LARGEST REC A/C ³	5 Tons		
NOMINAL TEMP RISE	66°	66°	66°
CASING HEIGHT (IN.):	50-1/8"		
CASING WIDTH (IN.):	24-1/2"		
CASING DEPTH (IN.):	36-1/2"		
NOMINAL FLUE OUTLET DIA.	7"		
APPROX SHIPPING WEIGHT (LBS)	316		
APPROVAL AGENCY	ETL		
QTY AND SIZE OF PERMANENT FILTERS	(1) 24-3/4" X 19-3/4"		
ELECTRICAL REQUIREMENTS	120/60/1		
MAX FUSE SIZE	20		
TOTAL CURRENT(AMPS) PSC / CTM	16 / 14.1		
HEIGHT FROM FLOOR TO CENTER OF FLUE	42-3/4"		
SUPPLY AIR OUTLET SIZE (W-IN. X D-IN.)	20" X 20"		
RETURN AIR DUCTWORK CONNECTION FLANGE SIZE ON FILTER RACK (D-IN. X H-IN.)	23-3/4" X 19"		
RETURN AIR INLET OPENING SIZE IN SIDE CASING (TO BE CUT-OUT BY DEALER) (D-IN. X H-IN.)	23" X 16-3/8"		
PROGRAMMABLE T-STAT STD/DELUXE	350164 / 350165		
FIELD VENT TERMINATION KIT	AOPS8414		
SIDEWALL VENT ACCESSORIES KIT	AOPS8394		
COMBUSTION AIR KIT FOR BECKETT	AOPS8397		
BLOCKED VENT KIT ⁴	AOPS2687		

* AS SHIPPED SETTING

- SEE NEXT PAGE FOR MORE DATA -

1 OUTPUT BTUH BASED ON ANNUAL FUEL UTILIZATION EFFICIENCY RATED BY MANUFACTURER.

2 SEASONAL EFFICIENCY (ALSO CALLED AFUE - ANNUAL FUEL UTILIZATION EFFICIENCY) RATINGS ARE BASED ON TESTS FOLLOWING U.S. DEPARTMENT OF ENERGY TEST PROCEDURES.

3 TO PERMIT LARGEST RECOMMENDED AIR CONDITIONING (AT .5 STATIC PRESSURE), SELECTION OF THE HIGHEST MOTOR SPEED IS REQUIRED.

ALL SPECIFICATIONS ARE SUBJECT TO CHANGE WITHOUT NOTICE.

4 NOT TO BE USED IN SIDEWALL VENT APPLICATIONS, USE ONLY WHEN CHIMNEY VENTED.

OIL FIRED UPFLOW FURNACE SPECIFICATIONS

Model Number Digit	1	2	3	4	5	6	7	8	9	10	11	12
	Brand	Configuration	Heat Exchanger Identifier	Flue	Design Change	Capacity	Capacity	Capacity	Blower Motor Type	Airflow Capacity for Cooling	Airflow Capacity for Cooling	Burner
Oil Furnace Model Nomenclature	V	H	8	F	A	1	1	9	P	6	0	B
Example Model Numbers	V	H	8	F	A	1	1	9	T	6	0	B
V= Spirit	V											
H = Highboy		H										
8= Heat Exchanger Identifier			8									
F = Vertical Front Flue				F								
Design Change					A							
Heating Output MBTUH (000's) – factory shipped						1	1	9				
P = PSC¹, T = CTM²									P			
Airflow: 60MBTUH = 5 Tons @ 400cfm/ton										6	0	
B = Beckett AFG												B

- SEE NEXT PAGE FOR MORE DATA -

¹ PSC = PERMANENT SPLIT CAPACITOR
² CTM = CONSTANT TORQUE MOTOR E.C.M.

OIL FIRED UPFLOW FURNACE SPECIFICATIONS

BLOWER DATA:	VH8FA119P60B	VH8FA119T60B
BLOWER MODEL	DD 12-11T	DD 12-11T
MOTOR H.P.	3/4 HP	1 HP
MOTOR TYPE & NUMBER OF SPEEDS	PSC - 4	CTM - 5
HIGH SPEED AIRFLOW (SCFM) @ 0.5 IN. W.G. EXTERNAL STATIC PRESSURE:	2069	2045
Diameter x Width	11 x 11	11 x 11

BURNER DATA	BECKETT "AFG" S - PLATE 3383 (2-3/4U) 31517 CERAMIC		
AIR TUBE LENGTH (IN.)	4 ½"		
BURNER HEAD TYPE:	F6		
FUEL TYPE:	#2		
NOZZLE RATING (GPH):	1.10	1.00	0.85
SPRAY ANGLE (DEG.):	80°	80°	80°
SPRAY PATTERN:	HOLLOW (A)	HOLLOW (A)	HOLLOW (A)
OIL PUMP PRESSURE (PSIG):	120 PSI		
COMBUSTION CHAMBER TYPE:	REFRACTORY (SOFT FIBER)		

CLEARANCES	
	MINIMUM CLEARANCES TO COMUSTIBLE MATERIALS:
SIDES	0"
FRONT (SERVICE ACCESS)	24"
REAR	0"
FLUE	8"
TOP PLENUM	1"

- SEE NEXT PAGE FOR MORE DATA -

OIL FIRED UPFLOW FURNACE SPECIFICATIONS

VH8FA119P60B

ALTERATIONS REQ'D FOR A/C @ DESIGN EXTERNAL STATIC PRESSURE				
COOLING UNIT	HTG Speed by Input			Recommended CLG Speed
	Low Fire	Mid Fire	High Fire	
36,000	Low	ML	MH	Low
42,000	Low	ML	MH	Med Low
48,000	Low	ML	MH	Med High
60,000	Low	ML	MH	High

AS SHIPPED CLG. →

Speed Tap\ Static Pressure	Furnace Airflow (CFM) vs. External Static pressure (in. WC.)							
	0.1	0.2	0.3	0.4	0.5	0.6	0.7	
Low	1308	1300	1274	1265	1237	1169	1127	
ML	1583	1526	1515	1491	1458	1420	1371	
MH	1894	1874	1839	1804	1746	1683	1632	
High	2254	2228	2195	2181	2069	1995	1897	
Furnace Motor Current Draw (Amps/Watts) vs. External Static pressure (in. WC.)								
Low	7.56 698	6.99 660	6.66 637	6.50 623	6.21 602	5.91 578	5.83 568	
ML	9.21 867	8.44 801	8.19 786	8.01 772	7.61 745	7.28 715	6.93 687	
MH	10.6 1040	10.2 999	9.87 971	9.38 923	9.01 895	8.68 864	8.23 829	
High	13.5 1320	13.2 1290	12.8 1270	12.4 1240	11.3 1130	10.7 1090	10.2 1020	

Speed Tap\ Static Pressure	High Fire Temperature Rise vs. External Static pressure (in. WC.)							
	0.1	0.2	0.3	0.4	0.5	0.6	0.7	
Low	94	94	96	97	99	105	108	
ML	78	80	81	82	84	86	90	
MH	65	66	67	68	70	73	75	
High	54	55	56	56	59	62	65	

AS SHIPPED HTG. →

Speed Tap\ Static Pressure	Mid Fire Temperature Rise vs. External Static pressure (in. WC.)							
	0.1	0.2	0.3	0.4	0.5	0.6	0.7	
Low	84	84	86	87	89	94	98	
ML	70	72	73	74	76	78	80	
MH	58	59	60	61	63	65	68	
High	49	49	50	51	53	55	58	

Speed Tap\ Static Pressure	Low Fire Temperature Rise vs. External Static pressure (in. WC.)							
	0.1	0.2	0.3	0.4	0.5	0.6	0.7	
Low	72	72	73	74	76	80	83	
ML	59	61	62	63	64	66	68	
MH	49	50	51	52	54	56	57	
High	42	42	43	43	45	47	49	

- SEE NEXT PAGE FOR MORE DATA -

OIL FIRED UPFLOW FURNACE SPECIFICATIONS VH8FA119T60B

ALTERATIONS REQ'D FOR A/C @ DESIGN EXTERNAL STATIC PRESSURE				
COOLING UNIT	HTG Speed by Input			Recommended CLG Speed
	Low Fire	Mid Fire	High Fire	
36,000	ML	Med	MH	Low
42,000	ML	Med	MH	Med Low
48,000	ML	Med	MH	Med High
60,000	ML	Med	MH	High

AS SHIPPED CLG. →

Speed Tap\ Static Pressure	Furnace Airflow (CFM) vs. External Static pressure (in. WC.)						
	0.1	0.2	0.3	0.4	0.5	0.6	0.7
Low	1520	1429	1385	1311	1222	1139	1085
ML	1660	1593	1536	1491	1422	1369	1295
Med	1749	1693	1652	1572	1520	1465	1391
MH	1827	1766	1692	1674	1596	1540	1487
High	2253	2185	2142	2114	2045	1991	1955
Speed Tap\ Static Pressure	Furnace Motor Current Draw (Amps/Watts) vs. External Static pressure (in. WC.)						
	0.1	0.2	0.3	0.4	0.5	0.6	0.7
Low	2.62 211	2.81 228	2.92 237	3.07 253	3.22 268	3.35 279	3.46 289
ML	3.34 279	3.55 294	3.72 310	3.84 325	4.02 339	4.13 350	4.31 364
Med	3.74 314	3.91 327	4.11 345	4.25 360	4.39 374	4.60 390	4.74 406
MH	4.21 356	4.40 373	4.57 390	4.73 407	4.90 422	5.01 432	5.12 450
High	7.2 638	7.2 650	7.43 665	7.68 688	7.92 712	8.16 714	8.29 751
Speed Tap\ Static Pressure	High Fire Temperature Rise vs. External Static pressure (in. WC.)						
	0.1	0.2	0.3	0.4	0.5	0.6	0.7
Low	80	85	88	93	99	105	112
ML	73	76	79	81	85	89	94
Med	69	72	73	77	80	83	87
MH	66	69	72	72	76	79	82
High	54	56	57	57	59	61	62
Speed Tap\ Static Pressure	Mid Fire Temperature Rise vs. External Static pressure (in. WC.)						
	0.1	0.2	0.3	0.4	0.5	0.6	0.7
Low	72	77	80	84	90	97	102
ML	66	69	72	74	77	80	85
Med	63	65	67	70	73	75	79
MH	60	62	65	66	69	72	74
High	49	50	51	52	54	55	56
Speed Tap\ Static Pressure	Low Fire Temperature Rise vs. External Static pressure (in. WC.)						
	0.1	0.2	0.3	0.4	0.5	0.6	0.7
Low	62	66	68	71	77	82	86
ML	56	59	61	63	66	68	72
Med	54	55	57	60	62	64	67
MH	51	53	55	56	59	61	63
High	42	43	44	44	46	47	48

AS SHIPPED HTG. →

- SEE NEXT PAGE FOR MORE DATA -

OIL FIRED UPFLOW FURNACE SPECIFICATIONS

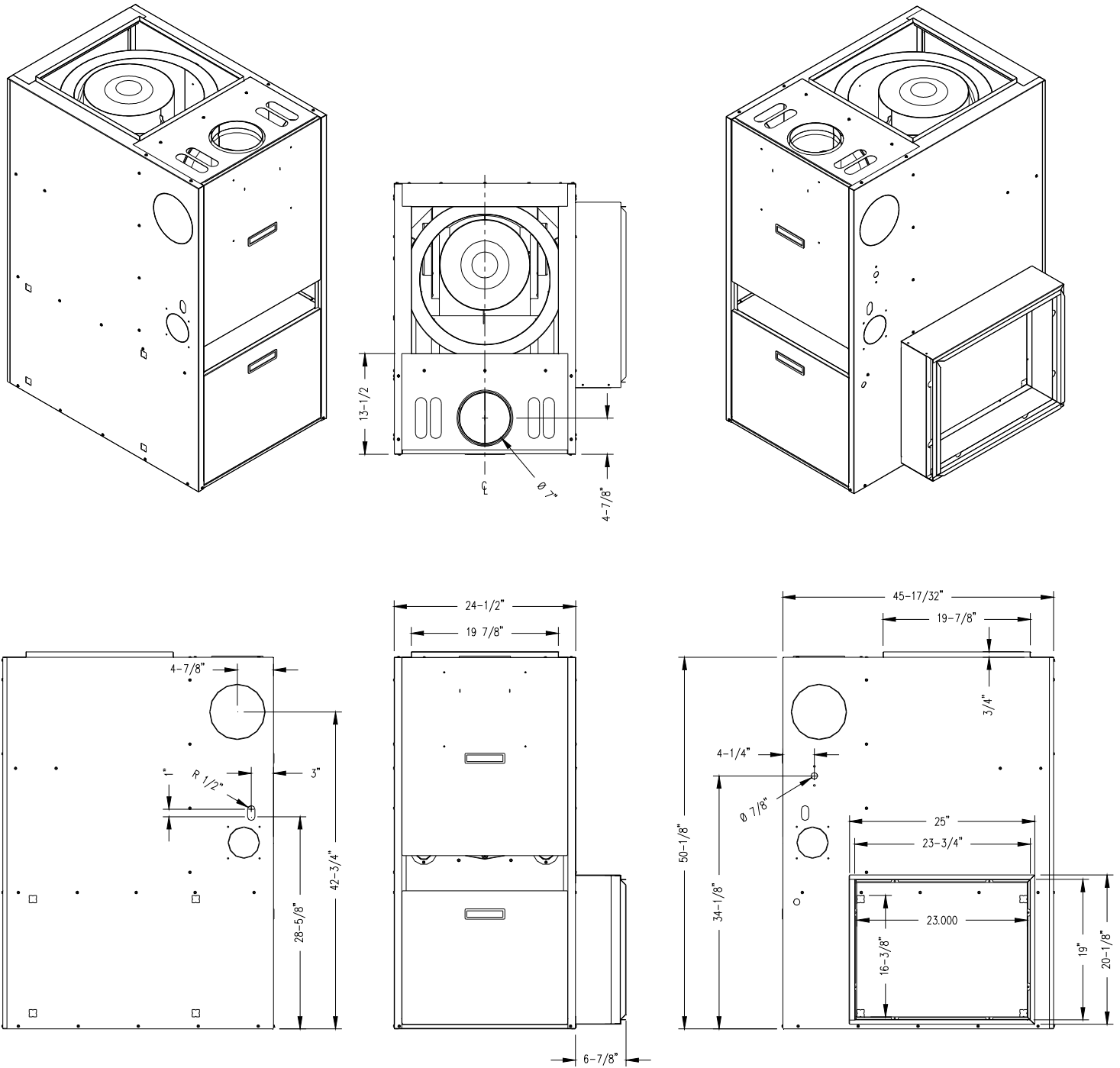

- SEE NEXT PAGE FOR MORE DATA -

OIL FIRED UPFLOW FURNACE SPECIFICATIONS

A/C Evaporator Coil Applications

Furnace Model Number	AC Tonnage	Model Number	Coil Model Number	Line Set	Capacity	EER	SEER	AHRI Reference Number
VH8FA119P60 VH8FA119T60	3	TCJD36S41S3	13U3030AB15, CA243620	LS01E-30	34400	11.00	13.00	6309406
		TCJD36S41S3	MC43C2XC1		35000	11.00	13.00	5612019
		TCJF36S41S3	MC43C2XC1+TXV (S1-1TVM4G1)	LS01E-50	34200	12.30	14.50	6873418
		TCJF36S41S3	13U3036AB17, CA303620		34200	12.00	14.50	6957650
		AL6B036F4	MC43C2XC1+TXV (S1-1TVM4N1)	34200	12.25	14.00	6873438	
		AL6B036F4	13U3036AB17, CA303620	34400	12.00	14.00	6957633	
	3.5	TCJD42S41S4	13U3642AB17, CA424220	LS02E-30	41500	11.00	13.00	6309410
		TCJD42S41S4	MC43C2XC1		41500	11.00	13.00	5611920
		TCJF42S41S3	MC43C2XC1+TXV (S1-1TVM4G1)	LS02E-50	40500	12.00	14.00	6873422
		TCJF42S41S3	MC48C3XC1+TXV (S1-1TVM4G1)		40500	12.00	14.50	6873423
		TCJF42S41S3	13U3642AB17, CA424220	40500	12.00	14.50	6957651	
		TCJF42S41S3	13U4248AB20, CA424820	40500	12.50	15.00	6957652	
		AL6B042F3	13U3642AB17, CA424220	40500	12.00	14.50	6957634	
		AL6B042F3	13U4248AB20, CA424820	41500	12.50	15.00	6957635	
	4	TCJD48S41S3	13U4248AB20, CA424820	LS02E-30	48000	11.00	13.00	6309413
		TCJD48S41S3	MC48C3XC1		48000	11.00	13.00	5612040
		TCJF48S41S4	MC48C3XC1+TXV (S1-1TVM4J1)	LS02E-50	44500	11.75	14.25	6873426
		TCJF48S41S4	13U4248AB20, CA424820		46000	12.50	15.00	6957654
		AL6B048F4	MC48C3XC1 + TXV (S1-1TVM4N1)	46500	12.25	14.00	6873444	
		AL6B048F4	13U3642AB17, CA424220	46000	12.00	14.00	6957636	
		AL6B048F4	13U4248AB20, CA424820	48000	12.00	14.50	6957637	
		AL6B048F4	13C4860AA26	48000	12.50	15.00	6957659	
	5	TCJD60S41S4	MC60D3XC1	LS02E-30	55000	11.00	13.00	7150042
		TCJF60S41S4	13C4860AA26		56000	12.00	14.50	6957656
		TCJF60S41S4	MC60D3XC1+TXV (S1-1TVM4J1)	LS02E-50	54500	11.75	13.50	6873429
		TCJF60S41S4	MC62D3XC1+TXV (S1-1TVM4J1)		56000	12.00	14.00	6873430
		AL6B060F3	13C4860AA26	53500	12.50	15.00	6957660	