



OIL FIRED COUNTERFLOW/*HORIZONTAL FURNACE SPECIFICATIONS

MODEL NO.	OD6F/RX072DV5R			
HEATING CAPACITY	LOW CAPACITY		HIGH CAPACITY	
	Low Fire	High Fire	Low Fire	High Fire
HEAT INPUT RATE (BTUH)	70,000	85,000	85,000	106,250
OUTPUT BTUH ¹	61,500	72,000	74,000	89,000
SEASONAL EFFICIENCY ²	86.0		85.0	
LARGEST REC A/C ³	5 tons		5 tons	
NOMINAL TEMP RISE	66°	66°	66°	66°
HEAT EXCHANGER AREA				
CASING HEIGHT (IN.):	45"			
CASING WIDTH (IN.):	20"			
CASING DEPTH (IN.):	30"			
NOMINAL FLUE OUTLET DIA.	5"			
APPROX SHIPPING WEIGHT	250 lbs.			
APPROVAL AGENCY	U.L.			
QTY AND SIZE OF PERMANENT FILTERS	(2) 18-3/4" x 12-3/4"			
ELECTRICAL REQUIREMENTS	120 / 60 / 1			
MAX FUSE SIZE ECM	15			
TOTAL CURRENT (AMPS) ECM	12.3			
HEIGHT FROM FLOOR TO CENTER OF FLUE (FRONT FLUE) (REAR FLUE)	40 3/4"			
SUPPLY AIR OUTLET SIZE (W-IN. X D-IN.)	18" x 20"			
RETURN AIR INLET OPENING SIZE	18" x 19"			
	ACCESSORY ITEMS			
BLOCKED VENT KIT ⁴	AOPS2686			

*Horizontal installation for left or right supply.

- SEE NEXT PAGE FOR MORE DATA -

¹ OUTPUT BTUH BASED ON ANNUAL FUEL UTILIZATION EFFICIENCY RATED BY MANUFACTURER.

² SEASONAL EFFICIENCY (ALSO CALLED AFUE - ANNUAL FUEL UTILIZATION EFFICIENCY) RATINGS ARE BASED ON TESTS FOLLOWING U.S. DEPARTMENT OF ENERGY TEST PROCEDURES.

³ TO PERMIT LARGEST RECOMMENDED AIR CONDITIONING (AT .5 STATIC PRESSURE), SELECTION OF THE HIGHEST MOTOR SPEED IS REQUIRED.

⁴ NOT TO BE USED IN SIDEWALL VENT APPLICATIONS, USE ONLY WHEN CHIMNEY VENTED.

Model Number Digit	1	2	3	4	5	6	7	8	9	10	11	12
	Fuel	Configuration	Heat Exchanger Identifier	Flue	Feature	Capacity	Capacity	Capacity	Blower Type	Clg Airflow Cap.	Clg Airflow Cap.	Burner
Oil Furnace Model Nomenclature Example Model Numbers	O	D	6	F	X	0	7	2	D	V	5	R
	O	D	6	R	X	0	7	2	D	V	5	R
O = Oil	O											
H = Highboy D = Dual Poise		D										
6 = Heat Exchanger Size Identifier			6									
F = Front				F								
R = Rear				R								
X = 2-Stage					X							
Heating Capacity MBTUH (000's) with factory installed nozzle						0	7	2				
D = Direct Drive									D			
Clg. Airflow Variable Speed (ECM) V5= 5tons										V	5	
R = Riello												R

- SEE NEXT PAGE FOR MORE DATA -

OIL FIRED COUNTERFLOW/HORIZONTAL FURNACE SPECIFICATIONS

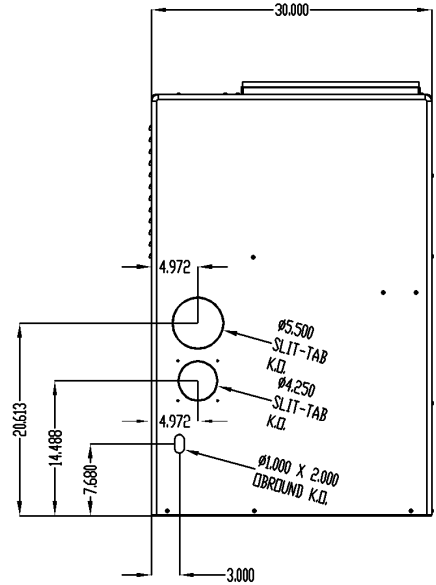
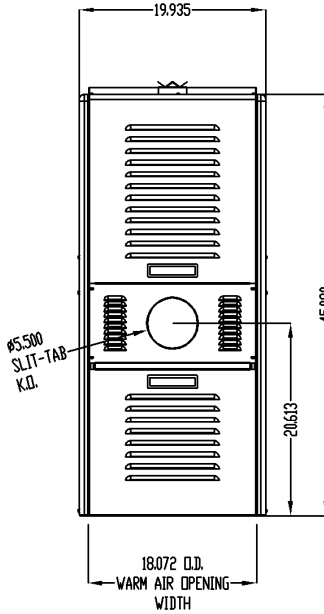
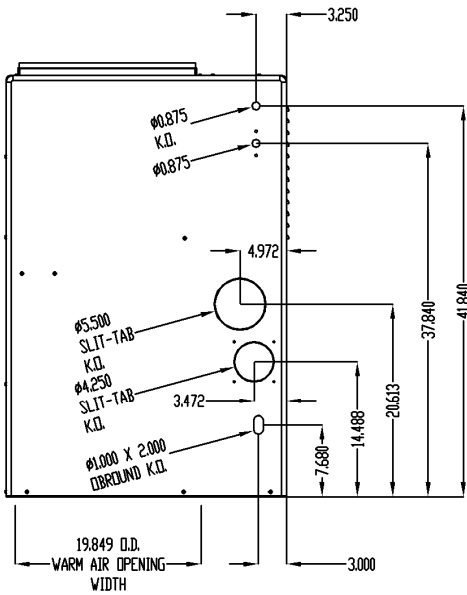
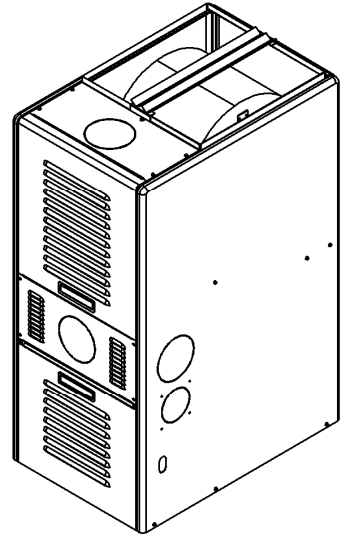
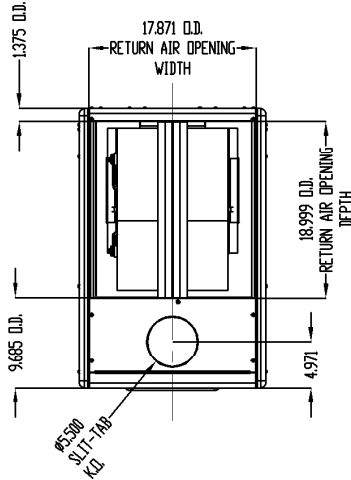
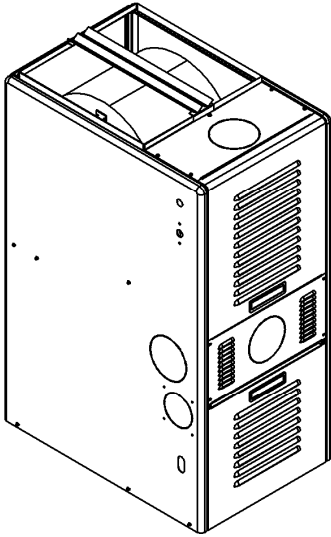

OD6FX072DV5

- SEE NEXT PAGE FOR MORE DATA -

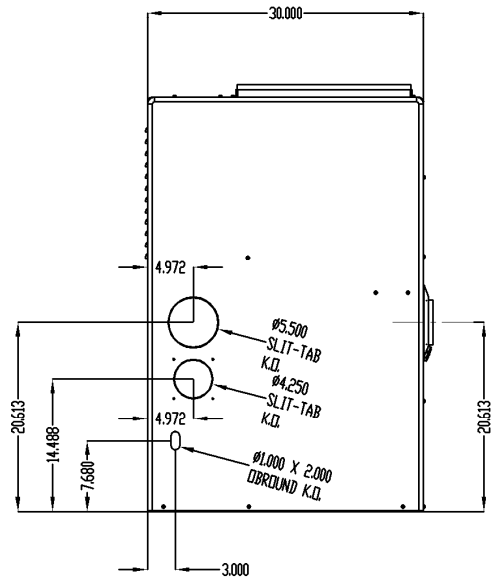
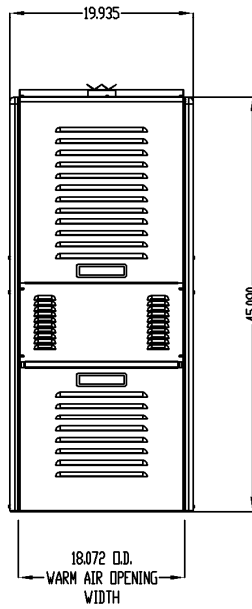
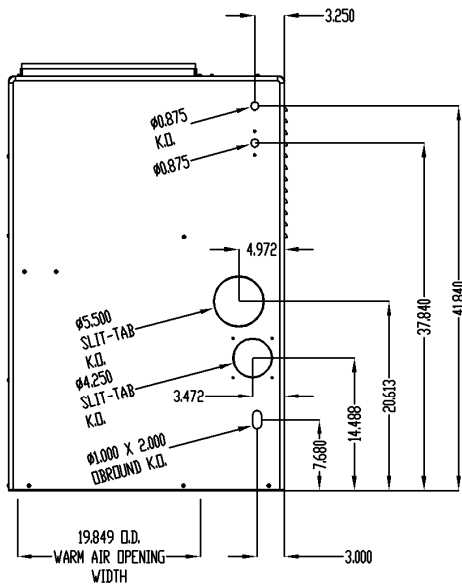
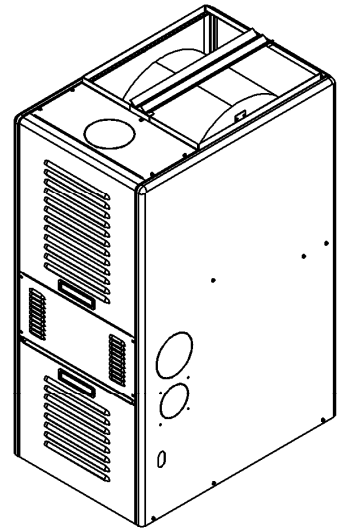
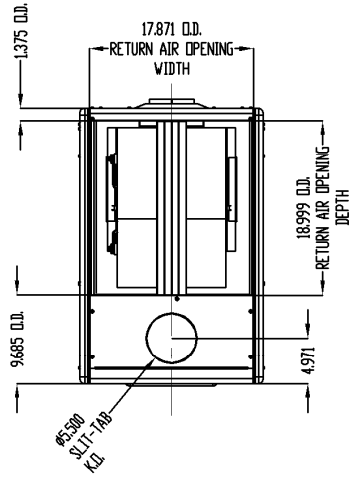
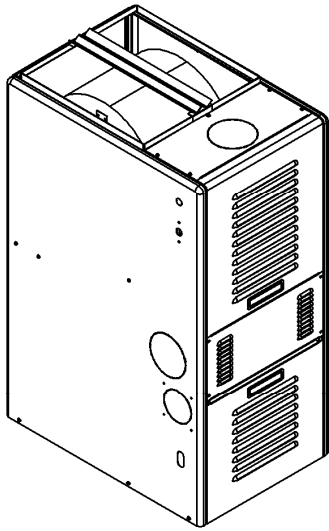

OD6RX072DV5

- SEE NEXT PAGE FOR MORE DATA -

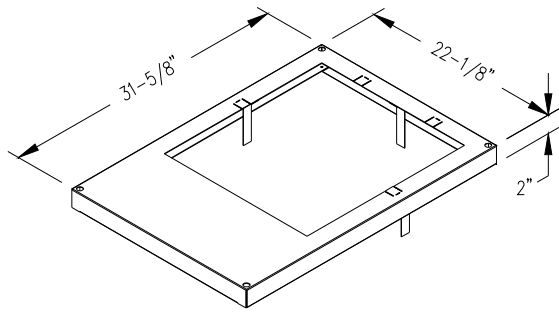

COMBUSTIBLE FLOOR BASE MODEL: D6-BASE

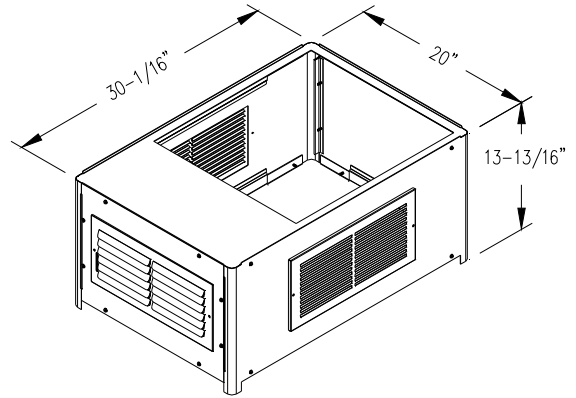

COTTAGE BASE MODEL: D6COT-BASE

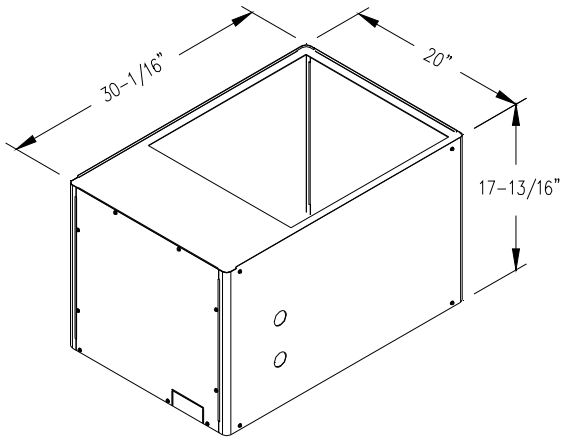

COIL CABINET MODEL: CE112S

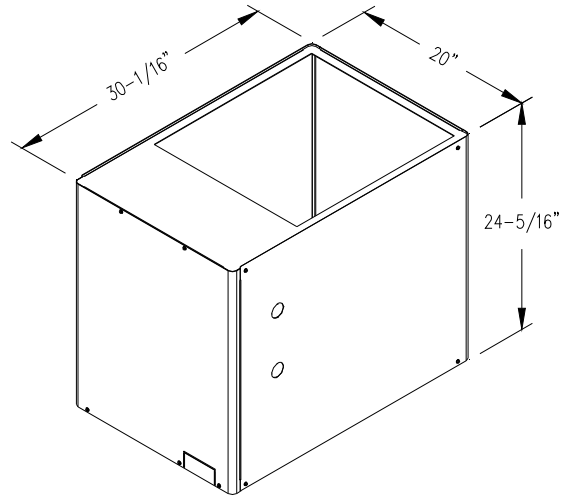

COIL CABINET MODEL: CE212T

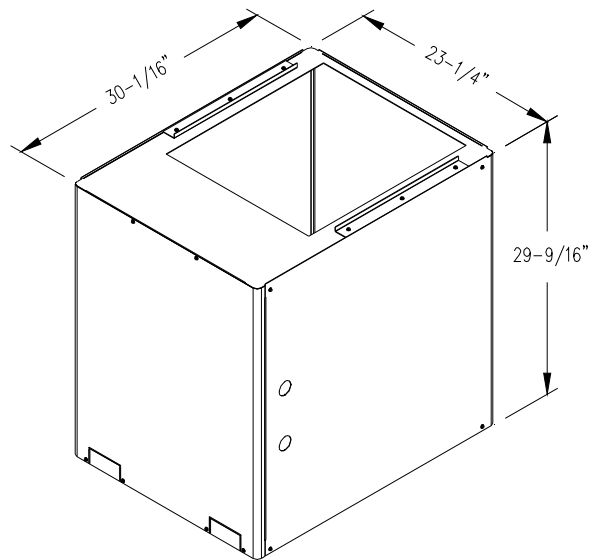

COIL CABINET MODEL: CE312T

- SEE NEXT PAGE FOR MORE DATA -

OIL FIRED COUNTERFLOW/HORIZONTAL FURNACE SPECIFICATIONS

BLOWER DATA:	OD6F/RX072DV5
BLOWER MODEL ⁴	12-9-T-DD-11
MOTOR H.P.	1 HP
MOTOR TYPE	ECM (CONSTANT CFM)
HIGH SPEED AIRFLOW (SCFM) @ 0.5 IN. W.G. EXTERNAL STATIC PRESSURE:	2000
Diameter x Width	12 x 9

BURNER DATA:	RIELLO G5D	
AIR TUBE LENGTH (IN.)	4 ¼"	
BURNER HEAD TYPE:	Fixed	
FUEL TYPE:	#2	
NOZZLE RATING (GPH):	.70	.50
SPRAY ANGLE (DEG.):	45°	45°
SPRAY PATTERN:	Semi-solid (W)	Semi-solid (W)
OIL PUMP PRESSURE (PSIG):	130 / 170	130 / 170
COMBUSTION CHAMBER TYPE:	REFRACTORY (SOFT CHAMBER)	

CLEARANCES	FRONT FLUE	REAR FLUE
	MINIMUM CLEARANCES TO COMUSTIBLE MATERIALS:	
SIDES	0"	0"
FRONT (SERVICE ACCESS)	(Clearance to Combustibles) 6" / 24" (Service)	(Clearance to Combustibles) 6" / 24" (Service)
REAR	0"	0"
FLUE	7"	7"
TOP	0"	0"
SUPPLY PLENUM	1"	1"

⁴ DD = DIRECT DRIVE

- SEE NEXT PAGE FOR MORE DATA -

OIL FIRED COUNTERFLOW/HORIZONTAL FURNACE SPECIFICATIONS

HEATING AIR FLOW / TEMPERATURE RISE

		LOW CAPACITY		HIGH CAPACITY	
FAN CONTROL SW 1 SWITCH SETTINGS	BTUH	LOW FIRE 60,000	HI FIRE 72,000	LOW FIRE 72,000	HI FIRE 90,000
	HEATING CFM	APPROX. CFM/RISE (°F)	APPROX. CFM/RISE (°F)	APPROX. CFM/RISE (°F)	APPROX. CFM/RISE (°F)
3 – OFF 2 – OFF 1 – OFF	755	604 / 91°	755 / 87°	604 / 109°	755 / 109°
3 – OFF 2 – OFF 1 – ON	826	661 / 83°	826 / 80°	661 / 100°	826 / 100°
3 – OFF 2 – ON 1 – OFF	898	718 / 70°	898 / 74°	718 / 92°	898 / 92°
3 – OFF 2 – ON 1 – ON	983	786 / 64°	983 / 67°	786 / 84°	983 / 84°
3 – ON 2 – OFF 1 – OFF	1068	854 / 59°	1068 / 62°	854 / 77°	1068 / 77°
3 – ON 2 – OFF 1 – ON	1168	934 / 54°	1168 / 57°	934 / 71°	1168 / 71°
Factory SW1 Switch Settings 3 – ON 2 – ON 1 – OFF	1282	1025 / 50°	1282 / 52°	1025 / 64°	1282 / 64°
3 – ON 2 – ON 1 – ON	1424	1139 / 48°	1424 / 46°	1139 / 58°	1424 / 58°

= Recommended heating speed setting

Cooling Speed set-ups

		Air Flow		
Fan Control SW 1 Switch Settings		Cig. Tonage	Cool	Continuous
	6-OFF 5-OFF 4-OFF		2	799
6-OFF 5-OFF 4-ON		2.5	1017	508
6-OFF 5-ON 4-OFF		3	1210	605
6-OFF 5-ON 4-ON		3.5	1404	702
Factory SW1 Switch Settings 6-ON 5-OFF 4-OFF		4	1622	799
6-ON 5-ON 4-OFF		5	2010	993