



OIL FIRED UPFLOW FURNACE SPECIFICATIONS

MODEL NO.	OH6FA072D48 / DV4 B			OH6FA072D48 / DV4 R			OH6FA072D48 / DV4 C		
HEATING CAPACITY	High Fire	Med Fire	Low Fire	High Fire	Med Fire	Low Fire	High Fire	Med Fire	Low Fire
HEAT INPUT RATE (BTUH)	106,250	85,000	70,000	106,250	85,000	70,000	106,250	85,000	70,000
OUTPUT BTUH ¹	89,000	72,000	60,000	90,000	73,000	60,000	90,000	71,000	60,000
SEASONAL EFFICIENCY ²	86.0%			86.1%			86.0%		
LARGEST REC A/C ³	4 Tons			4 Tons			4 Tons		
NOMINAL TEMP RISE	66°	66°	66°	66°	66°	66°	66°	66°	66°
BIO FUEL APPROVAL	B20			B5			B20		
CASING HEIGHT (IN.):	45"			45"			45"		
CASING WIDTH (IN.):	20"			20"			20"		
CASING DEPTH (IN.):	30"			30"			30"		
NOMINAL FLUE OUTLET DIA.	5"			5"			5"		
APPROX SHIPPING WEIGHT LBS	250			250			250		
APPROVAL STANDARDS	UL727 CAN/CSA B140.4			UL727 CAN/CSA B140.4			UL727 CAN/CSA B140.4		
QTY AND SIZE OF PERMANENT FILTERS	(1) 24 3/4" X 15 3/4"			(1) 24 3/4" X 15 3/4"			(1) 24 3/4" X 15 3/4"		
ELECTRICAL REQUIREMENTS VAC/HZ/PH	120/60/1			120/60/1			120/60/1		
MAX FUSE SIZE (AMPS) PSC/ECM	15 / 15			15 / 15			15 / 15		
TOTAL CURRENT (AMPS) PSC/ECM	8.7 / 12.1			8.7 / 12.1			8.7 / 12.1		
HEIGHT FROM FLOOR TO CENTER OF FLUE	40 3/4"			40 3/4"			40 3/4"		
SUPPLY AIR OUTLET SIZE (W-IN. X D-IN.)	18" X 19" (20" X 20") ⁵			18" X 19" (20" X 20") ⁵			18" X 19" (20" X 20") ⁵		
RETURN AIR DUCTWORK CONNECTION FLANGE SIZE ON FILTER RACK (D-IN. X H-IN.)	24 1/2" X 15"			24 1/2" X 15"			24 1/2" X 15"		
RETURN AIR INLET OPENING SIZE IN SIDE CASING (TO BE CUTOUT BY DEALER) (D-IN. X H-IN.)	23" X 14"			23" X 14"			23" X 14"		
	ACCESSORY ITEMS								
2-LINE SYSTEM KIT FOR RIELLO	N/A			380705			N/A		
COMBUSTION AIR KIT	AOPS8397			AOPS8416			AOPS8433		
FIELD VENT TERMINATION KIT	AOPS8393			AOPS8393			AOPS8393		
SIDEWALL VENT ACCESSORIES KIT	AOPS8394			AOPS8395			AOPS8432		
BLOCKED VENT KIT ⁴	350156			350156			350156		
OIL BURNER	BECKETT AFG (380692)			RIELLO BF3 (380693)			CARLIN EZ-1HP (380835)		
SUPPLY PLENUM	PK181X191			PK181X191			PK181X191		
RETURN BOOT & DROP KIT	RD2510X2516			RD2510X2516			RD2510X2516		
CASED COIL 2-3 TON	HE33936PA212			HE33936PA212			HE33936PA212		
CASED COIL 2-3 TON HIGH EFF.	HE47936PA212			HE47936PA212			HE47936PA212		
CASED COIL 3.5-4 TON	HE50960PA212			HE50960PA212			HE50960PA212		

¹ OUTPUT BTUH BASED ON ANNUAL FUEL UTILIZATION EFFICIENCY RATED BY MANUFACTURER.

² SEASONAL EFFICIENCY (ALSO CALLED AFUE - ANNUAL FUEL UTILIZATION EFFICIENCY) RATINGS ARE BASED ON TESTS FOLLOWING U.S. DEPARTMENT OF ENERGY TEST PROCEDURES.

³ TO PERMIT LARGEST RECOMMENDED AIR CONDITIONING (AT .5 STATIC PRESSURE), SELECTION OF THE HIGHEST MOTOR SPEED IS REQUIRED.

⁴ NOT TO BE USED IN SIDEWALL VENT APPLICATIONS, USE ONLY WHEN CHIMNEY VENTED.

⁵ PLENUM ADAPTERS INCLUDED WITH UNIT MUST BE INSTALLED FOR 20"x20" PLENUM.

Model Number Digit	1	2	3	4	5	6	7	8	9	10	11	12
	Fuel	Configuration	Heat Exchanger Identifier	Flue	Design Change	Capacity	Capacity	Capacity	Blower Type	Clg Airflow Cap.	Clg Airflow Cap.	Burner
Oil Furnace Model Nomenclature Example Model Numbers	O	H	6	F	A	0	7	2	D	4	8	B
	O	H	6	F	A	0	7	2	D	V	4	R
O = Oil	O											
H = Highboy		H										
6 = Heat Exchanger Size Identifier			6									
F = Front				F								
Design Change					A							
Heating Capacity MBTUH (000's) with factory installed nozzle						0	7	2				
D = Direct Drive									D			
Clg. Airflow: Example = 48MBTUH = 4 tons @ 400cfm/ton										4	8	
Clg. Airflow Variable Speed (ECM) V4= 4tons										V	4	
B = Beckett, R = Riello, C = Carlin												B

- SEE NEXT PAGE FOR MORE DATA -

OIL FIRED UPFLOW FURNACE SPECIFICATIONS

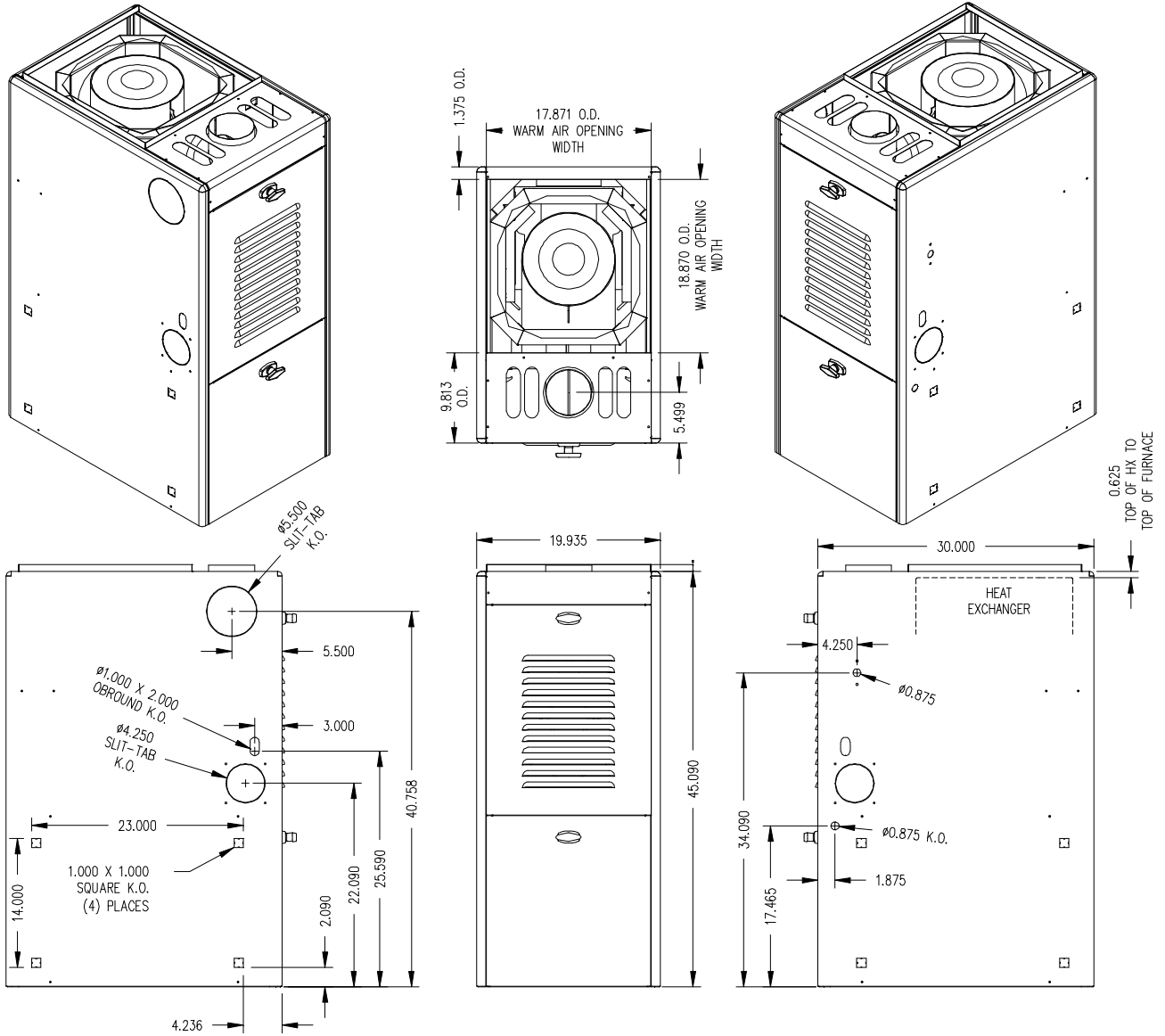

FILTER RACK SPECIFICATIONS

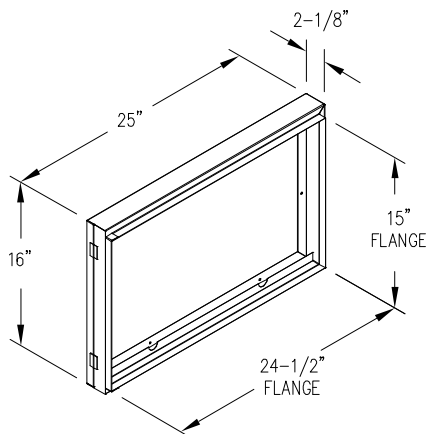

CLEARANCES	
	MINIMUM CLEARANCES TO COMUSTIBLE MATERIALS:
SIDES	0"
FRONT (SERVICE ACCESS)	(Clearance to Combustibles) 6"/ 24" (Service)
REAR	0"
FLUE	7"
TOP PLENUM	1"
SIDES PLENUM	1"

- SEE NEXT PAGE FOR MORE DATA -

OIL FIRED UPFLOW FURNACE SPECIFICATIONS

BLOWER DATA:	OH6FA072D48	OH6FA072DV4
BLOWER MODEL DIRECT DRIVE	DD 100-9R	DD 100-9R
MOTOR H.P.	½ HP	¾ HP Variable Speed
MOTOR TYPE & NUMBER OF SPEEDS	PSC - 4	ECM -
HIGH SPEED AIRFLOW (SCFM) @ 0.5 IN. W.G. EXTERNAL STATIC PRESSURE:	1569	1600
Diameter x Width (IN.)	10 x 9	10 x 9

BURNER DATA	RIELLO "BF3" WITH CERA-FELT SLEEVE		
AIR TUBE LENGTH (IN.)	4 ½"		
BURNER HEAD TYPE:	Fixed		
FUEL TYPE / BIO APPROVAL:	#2 / B5		
NOZZLE RATING (GPH):	.70	.60	.50
SPRAY ANGLE (DEG.):	80°	80°	80°
SPRAY PATTERN:	HOLLOW (A)	HOLLOW (A)	HOLLOW (A)
OIL PUMP PRESSURE (PSIG):	140 PSI		
COMBUSTION CHAMBER TYPE:	REFRACTORY (SOFT CHAMBER)		

BURNER DATA	BECKETT "AFG" S - PLATE 3912 (3 5/8") 31517 CERAMIC		
AIR TUBE LENGTH (IN.)	4 ½"		
BURNER HEAD TYPE:	F-3		
FUEL TYPE / BIO APPROVAL:	#2 / B20		
NOZZLE RATING (GPH):	.75	.60	.50
SPRAY ANGLE (DEG.):	70°	70°	70°
SPRAY PATTERN:	SOLID (B)	SOLID (B)	HOLLOW (A)
OIL PUMP PRESSURE (PSIG):	120 PSI		
COMBUSTION CHAMBER TYPE:	REFRACTORY (SOFT CHAMBER)		

BURNER DATA	CARLIN "EZ-1HP"		
AIR TUBE LENGTH (IN.)	4 ½"		
BURNER HEAD TYPE:	N/A		
FUEL TYPE / BIO APPROVAL:	#2 / B20		
NOZZLE RATING (GPH):	.75	.60	.50
SPRAY ANGLE (DEG.):	60°	60°	60°
SPRAY PATTERN:	HOLLOW (A)	HOLLOW (A)	HOLLOW (A)
OIL PUMP PRESSURE (PSIG):	120 PSI		
COMBUSTION CHAMBER TYPE:	REFRACTORY (SOFT CHAMBER)		

- SEE NEXT PAGE FOR MORE DATA -

OIL FIRED UPFLOW FURNACE SPECIFICATIONS

OH6FA072D48

ALTERATIONS REQ'D FOR A/C @ DESIGN EXTERNAL STATIC PRESSURE				
COOLING UNIT	HTG Speed by Input			Recommended CLG Speed
	Low Fire	Mid Fire	High Fire	
24,000	Low	ML	MH	Low
30,000	Low	ML	MH	Med Low
36,000	Low	ML	MH	Med High
42,000	Low	ML	MH	Med High
48,000	Low	ML	MH	High

Speed Tap\ Static Pressure	Furnace Airflow (CFM) vs. External Static pressure (in. WC.)						
	0.1	0.2	0.3	0.4	0.5	0.6	0.7
Low	930	915	912	910	822	774	730
ML	1155	1152	1130	1126	1085	1042	920
MH	1442	1432	1418	1382	1334	1293	1230
High	1802	1762	1705	1635	1569	1493	1428
Speed Tap\ Static Pressure	Blower Motor Current Draw (Amps) vs. External Static pressure (in. WC.)						
	0.1	0.2	0.3	0.4	0.5	0.6	0.7
Low	3.28	3.1	3.02	2.91	2.64	2.49	2.36
ML	4.18	4.02	3.91	3.74	3.59	3.34	2.95
MH	5.44	5.17	4.95	4.72	4.43	4.21	3.95
High	6.61	6.36	6.04	5.73	5.46	5.17	4.9

Speed Tap\ Static Pressure	High Fire Temperature Rise vs. External Static pressure (in. WC.)						
	0.1	0.2	0.3	0.4	0.5	0.6	0.7
Low	90	91	91	92	101	108	114
ML	72	72	74	74	77	80	91
MH	58	58	59	60	62	64	68
High	46	47	49	51	53	56	58

Speed Tap\ Static Pressure	Mid Fire Temperature Rise vs. External Static pressure (in. WC.)						
	0.1	0.2	0.3	0.4	0.5	0.6	0.7
Low	72	73	73	73	81	86	91
ML	58	58	59	59	61	64	72
MH	46	47	47	48	50	52	54
High	37	38	39	41	42	45	47

Speed Tap\ Static Pressure	Low Fire Temperature Rise vs. External Static pressure (in. WC.)						
	0.1	0.2	0.3	0.4	0.5	0.6	0.7
Low	60	61	61	61	68	72	76
ML	48	48	49	49	51	53	60
MH	39	39	39	40	42	43	45
High	31	32	33	34	35	37	39

- SEE NEXT PAGE FOR MORE DATA -

OIL FIRED UPFLOW FURNACE SPECIFICATIONS

OH6FA072DV4

Heating Speed Set-ups

NRGMAX Control	BTUH	Low Fire	Med Fire	High Fire	Static Pressure (Amps/Watts)		UT Control	
		60,000	72,000	90,000				
ECM Blower Heat Switch Settings	Heating CFM	Aprox. Rise (F°)	Aprox. Rise (F°)	Aprox. Rise (F°)	0.2	0.5	Fan Control SW 1 Switch Settings	
3-OFF 2-OFF 1-OFF	740	75°			1.1/98	1.8/173	3-OFF 2-OFF 1-OFF	
3-OFF 2-OFF 1-ON	812	68°	82°		1.3/114	2.1/193	3-OFF 2-OFF 1-ON	
3-OFF 2-ON 1-OFF	883	63°	76°		1.5/129	2.4/218	3-OFF 2-ON 1-OFF	
Factory Switch Settings	3-OFF 2-ON 1-ON	968	57°	69°	86°	1.7/148	2.4/223	3-OFF 2-ON 1-ON
	3-ON 2-OFF 1-OFF	1054		63°	79°	1.9/173	2.7/246	3-ON 2-OFF 1-OFF
	3-ON 2-OFF 1-ON	1153		58°	72°	2.3/207	3.0/283	3-ON 2-OFF 1-ON
	3-ON 2-ON 1-OFF	1267			66°	2.7/247	3.5/332	3-ON 2-ON 1-OFF
	3-ON 2-ON 1-ON	1424			58°	3.4/315	4.3/409	3-ON 2-ON 1-ON

= Recommended Heating Speed Setting

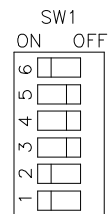

- SEE NEXT PAGE FOR MORE DATA -

OIL FIRED UPFLOW FURNACE SPECIFICATIONS

OH6FA072DV4

Cooling Speed Set-ups

NRGMAX Control	Air Flow	Static Pressure (Amps/Watts)		UT Control		
		Cool	Continuous		0.2	0.5
ECM Blower Cool Switch Settings	Clg. Tonage	Cool	Continuous	0.2	0.5	Fan Control SW 1 Switch Settings
3-OFF 2-OFF 1-OFF	2	799	500	1.2/109	2.1/186	6-OFF 5-OFF 4-OFF
3-OFF 2-OFF 1-ON	2.5	1017	508	1.8/160	2.5/230	6-OFF 5-OFF 4-ON
3-OFF 2-ON 1-OFF	3	1210	605	2.4/220	3.3/308	6-OFF 5-ON 4-OFF
3-OFF 2-ON 1-ON	3.5	1404	702	3.2/305	4.2/409	6-OFF 5-ON 4-ON
Factory Switch Settings	4	1622	799	4.6/443	5.7/560	6-ON 5-OFF 4-OFF

