

INSTRUCTIONS FOR CONVERTING THERMO PRIDE MID-EFFICIENCY GAS FIRED FURNACES

THIS KIT CONTAINS:

- AOPS7685 (NATURAL TO PROPANE CONVERSION) GMD1-80, GMD2-80
- AOPS7686 (PROPANE TO NATURAL CONVERSION) GMD1-80, GMD2-80
- AOPS7696 (NATURAL TO PROPANE CONVERSION) GMD1-60, GMD2-60
- AOPS7697 (PROPANE TO NATURAL CONVERSION) GMD1-60, GMD2-60

WARNING

This conversion kit shall be installed by a qualified service agency in accordance with the manufacturer's instructions and all applicable codes and requirements of the authority having jurisdiction. If the information in these instructions is not followed exactly, a fire an explosion or production of carbon monoxide may result causing property damage, personal injury or loss of life. The qualified service agency is responsible for the proper installation of this kit. The installation is not proper and complete until the operation of the converted appliance is checked as specified in the manufacturer's instructions supplied with the kit.

The installation of this conversion kit and any other service done to this furnace must be done only by a qualified service agency. These instructions must be read in their entirety before converting the furnace. It is also necessary to reference the original instruction manual for the installation, service and repair of the furnace being converted. That instruction manual will reference codes and regulations to which the original installation and this conversion must comply. Reference that instruction manual for the unit installation and operational instructions. Follow the installation instructions for the test fire subsequent to this conversion. The following instructions will outline the procedure for converting the existing burner from one type of gas to another. Any reference to L.P. or propane gas in this manual, any other label, or markings on the furnace is to be construed to be propane HD-5, a commercial grade of liquefied petroleum gases composed of a minimum of 90 percent liquid propane (C₃H₈).

When making a gas conversion, it is necessary to replace and/or modify several of the existing components. Table 1, shown below, describes these components and shows the correct model or size for each type of gas, propane or natural.

Table 1: Contents of the Thermo Pride Gas Conversion Kits

FURNACE MODEL	CONVERSION KIT PART NO.	CONTENTS				
		Main Burner Orifice			Gas Valve Pressure Regulator Kit (White-Rodgers Part #)	Thermo Pride Conversion Label Part Number
		QTY.	DRILL SIZE	IN.		
GMD1-80 GMD2-80	AOPS7685 (NAT. to LP)	3	#53	.0595	92-0659	390425
GMD1-80 GMD2-80	AOPS7686 (LP to NAT.)	3	2.45 MM	.0965	92-0656	
GMD1-60 GMD2-60	AOPS7696 (NAT. to LP)	2	#52	.0635	92-0659	
GMD1-60 GMD2-60	AOPS7697 (LP to NAT.)	2	#38	.1015	92-0656	

MANIFOLD REMOVAL AND ORIFICE CHANGE

⚠WARNING: Make sure that pipe dope or sealant is design certified to be resistant to the action of liquefied petroleum gases is used on all threaded joints.

⚠CAUTION: The gas supply shall be shut off prior to disconnecting the electrical power before proceeding with the conversion.

1. Shut off gas and power to the furnace.
2. Disconnect the furnace from the gas supply system at the union.
3. Remove the burner box cover by removing the outer row of screws holding the cover (See figure 1).

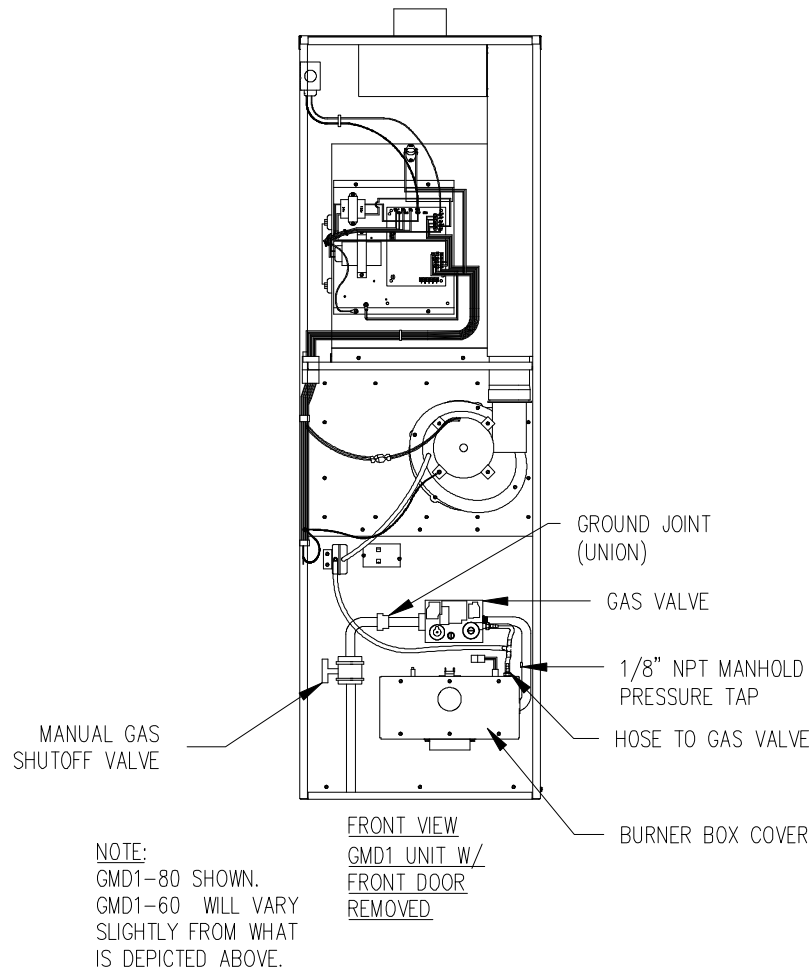

Figure 1.

4. Remove the four screws securing the manifold in the burner box. Pull the manifold far enough out of the burner box to access the burner orifices. (See figure 2)
5. Remove the main burner orifices from the manifold using a 1/2-inch wrench. Replace the existing main burner orifices with conversion orifices as referenced in the chart on the front cover.
6. Refer to the instruction provided in the gas valve conversion kit for regulator spring change out instructions.

7. Reinstall the manifold into the burner box. Make sure that all the orifices go into their respective burners. Make sure the groove of the rubber grommet on the manifold lines up on the edge of the burner box to seal around the manifold. Secure the manifold with four screws. (See figure 2).
 8. Inspect the seal on the burner box cover and if damaged repair it. Install and secure the burner box cover. Make sure all the fastening screws are used.
 9. Check to make sure that the electrical connections to the gas valve are not loose.
 10. Check that the plastic hose from the pressure switch is attached securely to the hose barb at the outlet of the gas valve without being kinked.
- ⚠CAUTION:** The regulator of the gas valve will not function properly if this hose connection is not made.
11. Reconnect the furnace to the gas supply.

Once ignition has been established, the gas supply should be turned off to allow attachment of a manometer (pressure gauge) to both the inlet of the gas valve and the manifold to confirm that gas pressures are within the tolerances listed below. (Pressures are listed in inches water column).

GAS TYPE	PROPANE	NATURAL
NORMAL MANIFOLD PRESSURE	10.0" \pm .3	3.5" \pm .3
MAXIMUM GAS SUPPLY PRESSURE	14.0"	14.0"
MINIMUM GAS SUPPLY PRESSURE	11.0"	5.5"

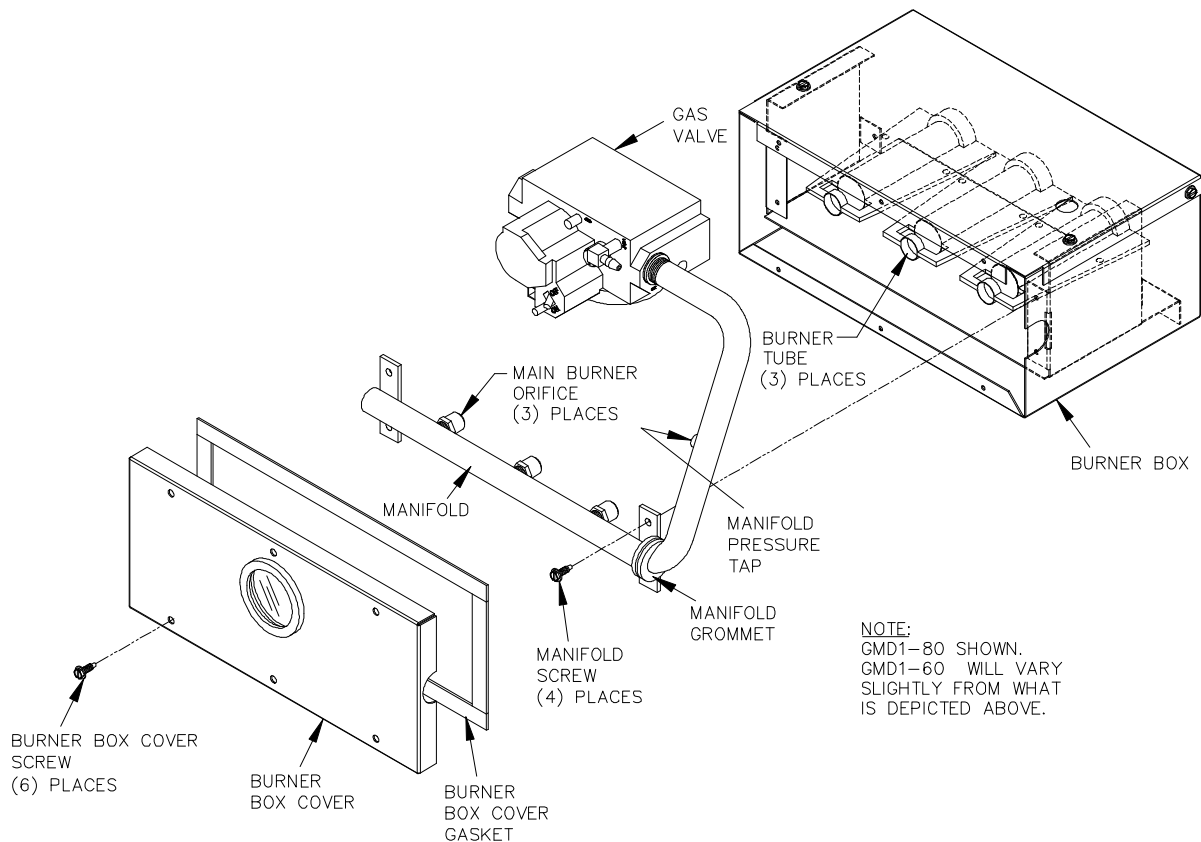

Figure 2.

CAUTION

1. Do not exceed input rating stamped on appliance nameplate or manufacturer's recommended burner orifice pressure for size orifice(s) used.
2. CHECKING GAS INPUT BY CLOCKING GAS METER:
 - Ensure that the only gas flow through the meter is that of the appliance being tested.
 - Ensure other appliances are turned off and their pilot flames are extinguished (or deduct their gas consumption from the meter reading).
 - Convert flow rate to BTUH as described (in following section) and compare to BTUH input rating on appliance nameplate.
3. CHECKING GAS PRESSURE WITH MANOMETER:
 - Ensure gas control switch is in the off position before removing the manifold pressure tap plug to connect manometer (pressure gauge).
 - Move gas control switch back to off when removing gauge and replacing plug.
 - Shut off gas supply at the appliance service valve before removing outlet pressure tap plug and before disconnecting manometer and replacing outlet pressure tap plug.
 - Perform Gas Leak test at inlet and outlet pressure tap plug.

CHECKING GAS INPUT USING METER CLOCKING METHOD

To check the input rate of the furnace, allow the unit to operate for 15 minutes and proceed as follows:

1. Contact your gas supplier and ask for the BTU content (higher heating value) of one standard cubic foot of the fuel gas supplied to the appliance at the installation site. If the higher heating values are unavailable, it is reasonable to assume values of 1025 BTU/cu ft, for natural gas, or 2500 BTU/cu ft, for commercial propane gas.
2. With all other gas consuming appliances turned off and using a stopwatch, clock the time required for the (small) dial on the gas meter to make one full revolution. The meter dial will indicate how many cubic feet pass through the meter during one revolution, usually one, two or five. The unit must have been in operation at least 15 minutes before clocking.
3. The following formula may be used to calculate the heat input rate for the appliance:

$$\frac{\text{Gas heating value} \times \text{Amount of gas consumed}}{\text{Amount of time required to consume the gas}} = \text{Heat input rate, or}$$

$$\frac{\text{BTU/cu ft} \times \text{Number of cu ft} \times 3600 \text{ seconds}}{\text{Seconds for one revolution} \times 1 \text{ hour}} = \text{Input rate (BTU/hr).}$$

4. If necessary, adjust pressure regulator to match appliance rating.
 - a. Remove the pressure regulator adjustment cap screw (located on the front of the gas valve).
 - b. Using a screwdriver, turn inner adjustment screw clockwise to increase or counterclockwise to decrease gas pressure to main burner.
 - c. Always replace cap screw and tighten firmly to insure the proper operation of the gas valve and to prevent gas leakage.
5. Turn gas supply to other appliances back on and relight all pilot flames according to appliance manufacturer instructions.
6. Proceed to CHECKOUT.

CHECKING GAS PRESSURE USING A MANOMETER (PRESSURE GAUGE)

1. Move gas control switch to OFF.
2. Remove outlet pressure tap plug from gas control and connect pressure gauge.
3. Move gas control switch to ON position.
4. To obtain an accurate outlet pressure reading, main burner must be cycled ON and OFF several times
to stabilize the pressure regulator diaphragm.
5. Light main burner and read pressure gauge. **Note:** This furnace is equipped with a slow opening gas valve. After light off, it will take several seconds for the outlet to reach full operating pressure.
6. If necessary, adjust pressure regulator to match appliance rating.
 - a. Remove pressure regulator adjustment cap screw. (Located on the front of the gas valve.)
 - b. Using a screwdriver, turn inner adjustment screw clockwise to increase or counterclockwise to decrease gas pressure to main burner.
 - c. Always replace cap screw and tighten firmly to prevent gas leakage.
7. Move gas control switch to OFF.
8. Remove pressure gauge and replace outlet pressure tap plug and pressure regulator cap screw.
9. Proceed to CHECKOUT.

TEST FIRE UNIT

Before testing the furnace operation, make sure of the integrity of all electrical connections. Check all terminals, not just those recommended during conversion. It is possible to accidentally loosen a connection when converting the burner.

Once the power and gas supply have been restored and inspected, increase the thermostat setting to activate the ignition sequence. The ignition sequence should be as follows:

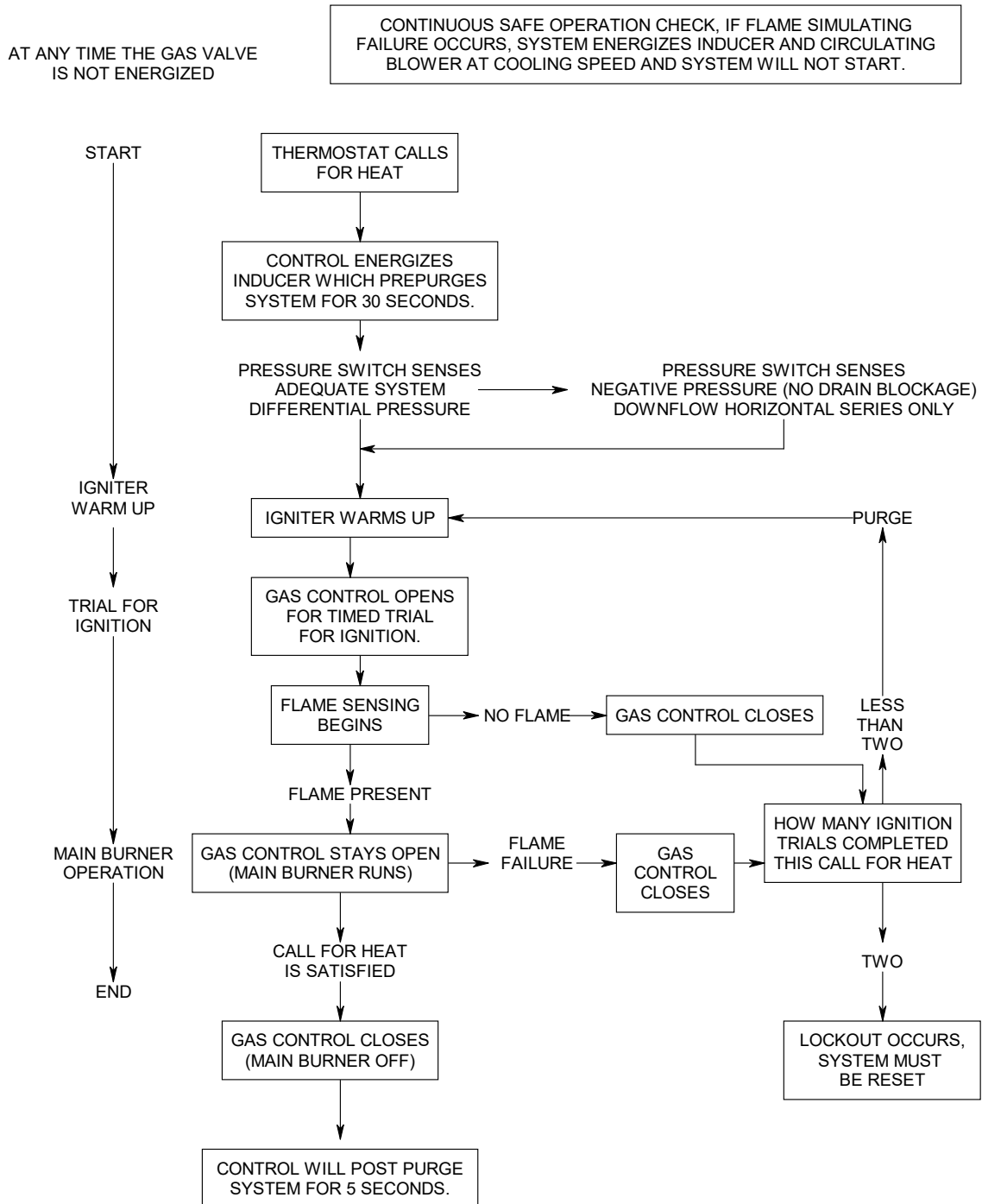

ADJUSTING BURNER INPUT FOR ALTITUDES ABOVE 2000 FEET

Ratings of gas utilization equipment are based on sea level operation and shall not be changed for operation at elevations up to 2,000 feet (600 m.). For operation at elevations above 2,000 feet (600 m.), equipment ratings shall be reduced at the rate of 4 percent for each 1,000 feet (300 m.) above sea level.

For additional information, refer to the latest edition of the National Fuel Gas Code.

CHECK OUT PROCEDURE:

CHECKING THE BURNER FLAME

Once the input has been confirmed as correct for the specific application, then the burner flame should be checked for proper adjustment.

This unit is designed to not require any burner adjustment. The flames should be checked by looking through the sight glass located on the burner box. Burner flames should be clear, blue and almost transparent in color. (see figure 3). NOTE: It is not unusual to have orangish flames visible in the tube for LP gas.

⚠CAUTION: Furnace models using inshot burners do not require an air shutter adjustment (air shutters are not used) for proper flame characteristics. The CCB1, CHB1, and GMD furnace models are sealed combustion design the burner box access cover must always be secured with all screws in place and tightened before operating furnace.

If combustion problems continue, refer to the unit installation and maintenance manual or contact Thermo Products at (574) 896-2133.

CHECKING THE FURNACE

1. Ensure that the furnace exhaust vent and combustion air intake are constructed as outlined in the installation and service manual and that they are not blocked or otherwise obstructed.
2. Place system in operation and observe through at least one complete cycle to ensure all controls are operating properly. Main burner must light reliably under all conditions.
3. Perform gas leak test on gas pipe connections and at pressure tap plugs.
4. Apply the gas conversion label to the gas control as well as applying the Thermo Pride conversion labels as close to the rating plate as possible.

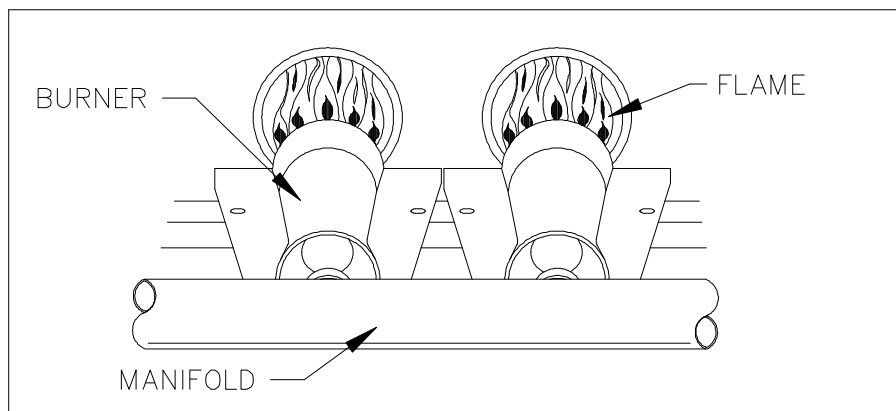

Figure 3.