

# Thermo Pride®

## OIL FIRED FURNACE INSTALLATION AND OPERATION MANUAL WITH USERS INFORMATION SECTION

### MODELS:

OT11-105FBP  
OT11-105RBP  
OT16-125FBP  
OT16-125RBP

OL5-85FDBP  
OL5-85RDBP  
OL11-105FDBP  
OL11-105FDBE  
OL11-105RDBP  
OL11-105RDBE

OL16-125FDBP  
OL16-125FDBE  
OL16-125RDBP  
OL16-125RDBE

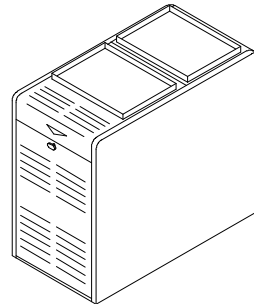
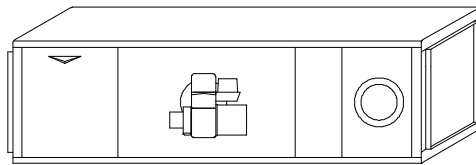

**⚠ WARNING:** IF THE INFORMATION IN THESE INSTRUCTIONS IS NOT FOLLOWED EXACTLY, A FIRE OR EXPLOSION MAY RESULT CAUSING PROPERTY DAMAGE, PERSONAL INJURY, OR LOSS OF LIFE.

DO NOT STORE OR USE GASOLINE OR OTHER FLAMMABLE VAPORS AND LIQUIDS IN THE VICINITY OF THIS OR ANY OTHER APPLIANCE.

**⚠ WARNING:** IMPROPER INSTALLATION, ADJUSTMENT, ALTERATION, SERVICE, OR MAINTENANCE CAN CAUSE INJURY OR PROPERTY DAMAGE. REFER TO THIS MANUAL. FOR ASSISTANCE OR ADDITIONAL INFORMATION CONSULT A QUALIFIED INSTALLER, OR SERVICE AGENCY.

**PLEASE READ THESE INSTRUCTIONS PRIOR TO INSTALLATION, INITIAL FIRING, AND BEFORE PERFORMING ANY SERVICE OR MAINTENANCE. THESE INSTRUCTIONS MUST BE LEFT WITH THE USER AND SHOULD BE RETAINED FOR FUTURE REFERENCE BY QUALIFIED SERVICE PERSONNEL.**



THERMO PRODUCTS, LLC.  
PO BOX 237  
DENTON, NC 27239  
PHONE: 800-476-4328



MADE IN USA



## I. SAFETY SECTION

This page contains various warnings and cautions found throughout the Oil Furnace Manual. Please read and comply with the statements below.

### **⚠WARNING AND CAUTIONS:**

**⚠WARNING:** This furnace is not to be used as a construction heater. See Page 2.

**⚠ CAUTION MUST BE TAKEN NOT TO EXCEED 90° ROTATION (OF THE FLUE ELBOW) COUNTERCLOCKWISE FROM THE VERTICAL POSITION.** See Page 3.

**⚠WARNING:** The predetermined limit locations on all of the Thermo Pride oil fired furnaces have been tested and approved by Thermo Products, LLC. In conjunction with Underwriters Laboratories, Inc. Any attempt to relocate these safety controls or replace these safety controls with a control that is not approved, or is incompatible, may result in personal injury, substantial property damage or death. See Page 4.

**⚠WARNING:** THE HEAT EXCHANGER MUST BE CLEANED BY A QUALIFIED SERVICE PERSON. See Page 9.

**⚠CAUTION:** DO NOT ATTEMPT TO MAKE REPAIRS YOURSELF! See Page 11.

**⚠WARNING:** The area around the furnace should be kept free and clear of combustible liquids and material, especially papers and rags. See Page 11.

**⚠WARNING:** NEVER burn garbage or refuse in your furnace. Never try to ignite oil by tossing burning papers or other material into your furnace. See Page 11.

**⚠WARNING:** Thermo Products oil furnaces are designed to burn No. 1 or No. 2 distillate fuel oil. **NEVER USE GASOLINE OR A MIXTURE OF OIL AND GASOLINE.** A Bio-fuel mixture may be used but the mixture is not to exceed a B5. See Page 11.

**⚠CAUTION:** DO NOT ATTEMPT TO START THE BURNER WHEN:

1. Excess oil has accumulated,
2. The furnace is full of vapors
3. The combustion chamber is very hot.

**IF ONE OR MORE OF THESE CONDITIONS EXIST, CONTACT A QUALIFIED SERVICE PERSON. See Page 11.**

**All installations and services must be performed by qualified service personnel.**

**This page contains reproductions of the various instruction and warning labels placed on the Thermo Pride Oil Furnaces. Please read and comply with the contents of these labels.**



OIL-FIRED FURNACE NO.  MODEL NO.

FOR USE WITH BECKETT (-B) OIL BURNER MODEL OR  
 RIELLO (-R) OIL BURNER MODEL  
 MAXIMUM INPUT G.P.H.  
 REFER TO BURNER LABEL FOR CONTROL AND FUEL SPECIFICATION.  
 INPUT OUTPUT 115 VOLTS 60 HZ  
 BTU/HR BELT DRIVE DIRECT DRIVE  
 TOTAL CURRENT AMPS  
 MINIMUM CIRCUIT AMPACITY  
 MAXIMUM FUSE SIZE  
 EXTERNAL STATIC PRESSURE (IN. W.C.) 0.20 TO 0.50  
 MAXIMUM DESIGNED OUTLET AIR TEMPERATURE 200°F OR LESS.  
 FOR INSTALLATION ON NON-COMBUSTIBLE FLOORING WITH CLEARANCES TO  
 UNPROTECTED COMBUSTIBLE MATERIAL NOT LESS THAN:  

(INCHES)	TOP	SIDES	REAR	FRONT	FLUE PIPE
	1	1	1	24	6

 ROOM MUST BE LARGE AS COMPARED TO SIZE OF FURNACE.

FOR MAXIMUM EFFICIENCY (AFUE) SET BURNER COMBUSTION FOR 12% CO<sub>2</sub> MINIMUM AND  
 FURNACE TEMPERATURE RISE FOR 70°F MAXIMUM.  
390425/D-0148-NA 1033-07 5325NAA THERMO PRODUCTS, LLC. - P.O. BOX 217 - NORTH JUDSON, IN 46366



**WARNING:** This product can expose you to chemicals, including Chromium, which are known to the state of California to cause cancer and birth defects or other reproductive harm. For more information go to [www.P65Warnings.ca.gov](http://www.P65Warnings.ca.gov).



**AVERTISSEMENT:** Ce produit peut vous exposer à des produits chimiques, y compris le chrome, qui sont connus dans l'état de Californie pour causer le cancer et des malformations congénitales ou d'autres problèmes de reproduction. Pour plus d'informations, visitez [www.P65Warnings.ca.gov](http://www.P65Warnings.ca.gov).

390341

THIS PANEL REMOVABLE BY QUALIFIED SERVICE PERSONNEL FOR ACCESS TO HEAT EXCHANGER CLEAN OUTS. BE CERTAIN CLEAN OUT GASKETS ARE INTACT AND THE COVERS IN PROPER POSITION TO ENSURE A COMPLETE SEAL PRIOR TO OPERATION.

390005

SHOULD THIS UNIT BE DISASSEMBLED ALL COMPONENTS, PANELS, BLOCK OFFS, COLLARS, GASKETS, AND FASTENERS MUST BE REASSEMBLED AS ORIGINALLY FACTORY PRODUCED.

390056

## WARNING

The following items should be inspected every year by a qualified heating contractor. Correct any deficiencies at once.

**Heat Exchanger:** Inspect for corrosion, pitting, warpage, deterioration, carbon build up and loose gaskets.

**Burner:** Check for correct operation, proper combustion, no fuel leakage, and if provided, clean burner filter.

**Chimney/Vent Pipe:** Inspect for restriction, loose joints, abnormal carbon build up and condensation.

**Controls:** Check for correct operation and proper settings, (if manually adjustable).

Periodic visual inspections should also be made by the owner during the heating season. Call a qualified heating contractor to report suspected deficiencies. (Do not attempt to make repairs yourself!)

Further owner and heating contractor responsibilities are detailed in the installation and maintenance instruction manual. (Shut off power before inspecting.)

390299

OUTSIDE POWER SOURCE 115 V. 60 CYCLE TO BE CONNECTED TO WIRES INSIDE THIS BOX. CONNECT WIRE #1 TO THE "HOT" LINE. CONNECT WIRE #2 TO THE "COMMON" LINE.

390004

**"DANGER— TO AVOID INJURY FROM MOVING PARTS SHUT OFF THE FURNACE BEFORE REMOVING THIS DOOR."**

WHEN IT BECOMES NECESSARY TO REPLACE OR WASH FILTER, REMOVE THE DIRTY FILTER FROM THE RACKS PROVIDED AND WASH OR REPLACE WITH IDENTICAL NEW FILTERS.

THE BLOWER MOTOR LOCATED BEHIND THIS DOOR MAY OR MAY NOT REQUIRE LUBRICATION. IF LUBRICATION INSTRUCTIONS ARE NOT SHOWN ON THE MOTOR NAME PLATE THE MOTOR SHOULD NOT BE LUBRICATED. IF THE NAME PLATE INDICATES THAT THE MOTOR REQUIRES LUBRICATION, LUBRICATE THE MOTOR AS DIRECTED OR USE 30 DROPS OF SAE 20 WEIGHT OIL OR EQUIVALENT TWICE A YEAR. DO NOT USE A LIGHT HOUSEHOLD GRADE OIL.

390025

**WARNING:** THIS UNIT MUST BE INSTALLED AND SERVICED BY A QUALIFIED CONTRACTOR ONLY.

390057

**All installations and services must be performed by qualified service personnel.**

**TABLE OF CONTENTS**

<b><u>SECTION</u></b>	<b><u>BEGINNING PAGE</u></b>
I. SAFETY SECTION	i
II. GENERAL INSTRUCTIONS	2
A. DRAFT REGULATORS	3
B. DUCT WORK/AIR CONDITIONING	4
C. HORIZONTAL FURNACE POSITIONS	5
D.    LIMIT POSITION AND LOCATION	5
E.    BURNER INSTALLATION	6
F.    EXTERNAL WIRE HARNESS LOCATIONS	8
G.    BURNER SPECIFICATIONS AND APPLICATIONS	8
H.    HEAT EXCHANGER CLEANING INSTRUCTIONS	9
III. USERS INFORMATION SECTION	11
A. OIL SUPPLY	11
B. COMBUSTION AIR SUPPLY	11
C. INSPECTION AREAS	11
D. STARTING THE BURNER	11
E. FILTER CLEANING AND LOCATION	12
APPENDIX – A    REPLACEMENT PARTS LIST	14
APPENDIX – B    WIRING DIAGRAMS	23

**All installations and services must be performed by qualified service personnel.**

**Packing List**

This Thermo Pride furnace was shipped from the factory with the below listed items for the final installation. Please contact Thermo Pride Customer Service if you are missing any of the items.

<b>LOWBOY UNITS:</b>	<b>OL5</b>	<b>OL11</b>	<b>OL16</b>	
ROCKWOOL INSULATION	1 BAG	1 BAG	1 BAG	
DOOR HANDLE	2 SETS	2 SETS	2 SETS	
DRAFT REGULATOR	6"	6"	7"	
OIL NOZZLE	.75X80°A	.90X80°A	1.10X80°A	
WIRE NUTS 74B	2	2	2	
BUSHING UB-875	1	1	1	
BUSHING 34-2	1	1	1	
LITERATURE PACKAGE	1	1	1	
<b>HORIZONTAL UNITS:</b>	<b>OT11F</b>	<b>OT11R</b>	<b>OT16F</b>	<b>OT16R</b>
ROCKWOOL INSULATION	1 BAG	1 BAG	1 BAG	1 BAG
DOOR HANDLE	1 SET	1 SET	1 SET	1 SET
DRAFT REGULATOR	6"	6"	7"	7"
OIL NOZZLE	.90X80°A	.90X80°A	1.10X80°A	1.10X80°A
WIRE NUTS 74 B	2	2	2	2
BUSHING UB-875	1	1	1	1
LITERATURE PACKAGE	1	1	1	1
THERMO PRIDE EMBLEM	1	1	1	1
LIMIT COVER w\ LABEL	1	-	1	-
COVER PLATE	1	-	1	-
SCREWS, 8X1/2	3	-	3	-

**All installations and services must be performed by qualified service personnel.**

## II. GENERAL INSTRUCTIONS - READ BEFORE START OF INSTALLATION

1. The heating output capacity of the furnace proposed for installation should be based on a heat loss calculation made according to the manuals provided by the Air Conditioning Contractors of America (ACCA) or the American Society of Heating, Refrigeration and Air Conditioning Engineers, Inc. (ASHRAE).

2. All local codes and/or regulations take precedence over the instructions in this manual and should be followed accordingly. In the absence of local codes, installation must conform with these instructions and regulations of the National Fire Protection Association, and to the provisions of the National Electrical Code (ANSI/NFPA 70-1999 or latest edition).

3. The installed furnace must be level and positioned in a central location with respect to outlet registers. It should be located near the chimney to minimize any horizontal run of flue pipe, which may be required.

4. A furnace installed in a residential garage must be installed so the burner and ignition source are located higher than 18 inches above the floor, unless the required combustion air is taken from the exterior of the garage. Also, the furnace must be located or protected to avoid physical damage by vehicles.

It is recommended that a commercially available CO alarm be installed in conjunction with any fossil fuel burning appliance. The CO alarm shall be installed according to the alarm manufacturer's installation instructions and be listed in accordance with the latest edition of the UL Standard for Single and Multiple Station Carbon Monoxide Alarms, UL 2034, or the CSA International Standard, Residential Carbon Monoxide Alarming Devices, CSA 6.19.

**⚠WARNING:** This furnace is not to be used as a construction heater.

5. Listed below are definitions of "COMBUSTIBLE MATERIAL" and "NON-COMBUSTIBLE MATERIAL."

### COMBUSTIBLE MATERIAL:

Material made of or surfaced with wood, compressed paper, plant fibers, plastics, or other material that will ignite and burn, whether flame resistant or not.

### NON-COMBUSTIBLE MATERIAL:

Material that is not capable of being ignited and burned. Such materials consist entirely of, or a combination of, steel, iron, brick, tile, concrete, slate, or glass.

### MINIMUM CLEARANCES TO COMBUSTIBLE MATERIALS

TYPE OF UNIT	MODEL NO. <sup>1</sup>	FROM SIDES OF FURNACE		FRONT	TOP & SIDES OF PLENUM	FROM THE FLUE/VENT	REAR
		FRONT	TOP	REAR	BOTTOM	FROM THE FLUE/VENT	ANY SIDE OF PLENUM
LOWBOYS		1"		24"	1"	6"	1"
	OL5,11,16						
HORIZONTALS <sup>2</sup>		24"		1"	1"	9"	1"
	OT11,16						

Notes:

<sup>1</sup>The above are abbreviated model numbers.

<sup>2</sup>Horizontal units are not approved for attic installation.

The minimum clearances listed in the preceding table are for fire protection. Clearance for servicing the front of the furnace and the rear of the lowboy models should be at least 24 inches. A clearance of 24 inches is recommended for passage to all points on the furnace requiring service access.

**All installations and services must be performed by qualified service personnel.**

**NOTE:** When power venting a Thermo Pride oil fired furnace with a power venting system other than the system supplied by Thermo Pride, a fiber chamber and an isolated combustion air kit (PVB or Beckett boot) is to be used with the other manufacturers power venting system.

**NOTE:** On the front flue, lowboy, it is possible to rotate the flue elbow (which is factory installed for vertical discharge) 90° counterclockwise from the vertical position to adapt to various venting systems. (See following page for details)

**⚠ CAUTION MUST BE TAKEN NOT TO EXCEED 90° ROTATION (OF THE FLUE ELBOW) COUNTERCLOCKWISE OR RIGHT FROM THE VERTICAL POSITION.**

**ROTATION OF FRONT FLUE ELBOW**

When an installation requires that the flue exit out the left hand side casing on a front flue unit, remove screw securing the 90 deg. elbow and rotate it 90° **counterclockwise**. Then, by following dimensions in Table 1, locate the center point for the exit of the flue for the particular size furnace. Once the center has been located, use a scribe to mark the hole size, listed in the chart, which corresponds with the furnace being used. Cut hole out and extend flue through side casing.

A trim collar may be ordered from Thermo Products to hide the gap around the flue pipe. This trim collar, however, is not required for operation.

**NOTE: ROTATION OF FLUE PIPE IS ONLY ALLOWED FOR LEFT HAND SIDE VENTING APPLICATIONS.**

**TABLE 1: Suggested sizes and positions of flue pipe opening on left hand side of casing.**

<b>UNIT</b>	<b>DIA. HOLE</b>	<b>“X” DIM.</b>	<b>“Y” DIM.</b>	<b>FLUE DIA.</b>	<b>TRIM COLLAR/ GASKET PART #</b>
OL5*	6-1/2”	4-5/8”	34-15/16”	6”	14131/330005
OL11*	6-1/2”	4-1/2”	37-5/8”	6”	14131/330005
OL16*	7-1/2”	4-1/2”	39-1/8”	7”	14132/330006

\* FRONT FLUE MODELS ONLY

“X” DIMENSION IS MEASURED FROM SEPARATOR PANEL.

“Y” DIMENSION IS MEASURED FROM THE BASE ON “L” MODELS.

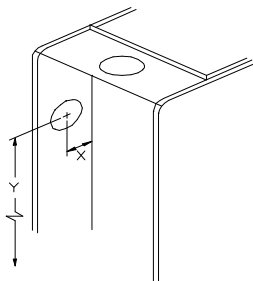

**Fig 1: Recommended location for drilling hole to connect vent pipe to the furnace through the left hand side casing.**

**A. DRAFT REGULATORS:**



**All installations and services must be performed by qualified service personnel.**

A draft regulator is supplied with the furnace and should be installed according to the regulator manufacturers recommendations. With the burner operating, use a draft gauge to adjust the regulator to the proper setting. (refer to the instructions enclosed with draft regulator to adjust to the proper setting). When the burner air supply and draft are properly adjusted, the overfire draft should be a negative (-).01" to (-).02" WC, as measured at the 5/16" overfire air tap (See Fig. 8). This tap is provided in the upper burner mounting plate. To measure the flue draft, punch a small hole in the vent connector pipe as close to the furnace as possible and always before the draft regulator.

**B. DUCT WORK/AIR CONDITIONING:**

If the furnace is used in connection with summer air conditioning (cooling), the furnace should be installed parallel with or on the upstream side of the evaporator coil to avoid condensation in the furnace heat exchanger. If the cooling unit is installed with a parallel flow arrangement, dampers or other means used to control flow of air should be provided to prevent chilled air from entering the furnace. If such a damper is manually operated, it must be equipped with a means to prevent operation of either unit, unless the damper is in the full heat or cool position.

The duct system should again follow the current design standard of Air Conditioning Contractors of America (ACCA) or ASHRAE Fundamentals volume.

The most common location for the A-shaped coil (A style) is shown in Fig. 2.

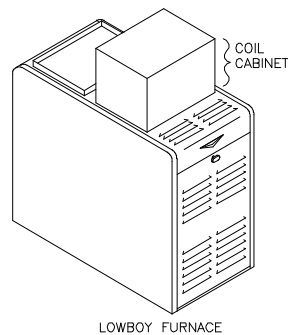

**Fig 2: Acceptable locations for the air conditioner evaporator coil.**

**NOTICE:** The minimum coil pan clearance for a sectional or drum type heat exchanger is three inches unless specified otherwise by the individual coil manufacturer.

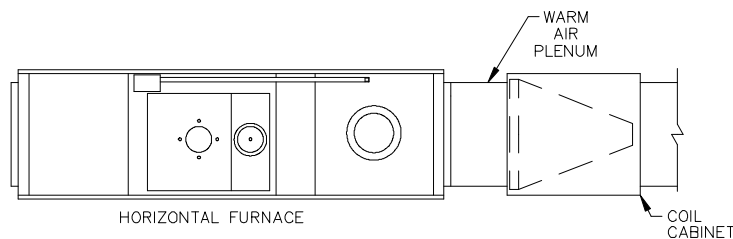

**Fig. 3: An acceptable location for the air conditioner evaporator coil when used with a horizontal furnace.**

To obtain proper airflow with an air conditioning coil installed on a direct drive unit the blower motor speed may need to be changed depending upon the size of the air conditioning system installed and the airflow resistance of the duct system.

Refer to wiring diagrams for blower motor speed selection tables. Nominal temperature rise range is 55° F to 85° F.

The furnace shall not be operated in a condition where the return air is consistently below 55°F.

**All installations and services must be performed by qualified service personnel.**

### C. HORIZONTAL FURNACE POSITIONS:

The horizontal furnace may be turned end for end, or rotated, making the top into the bottom, as shown in Fig. 11.

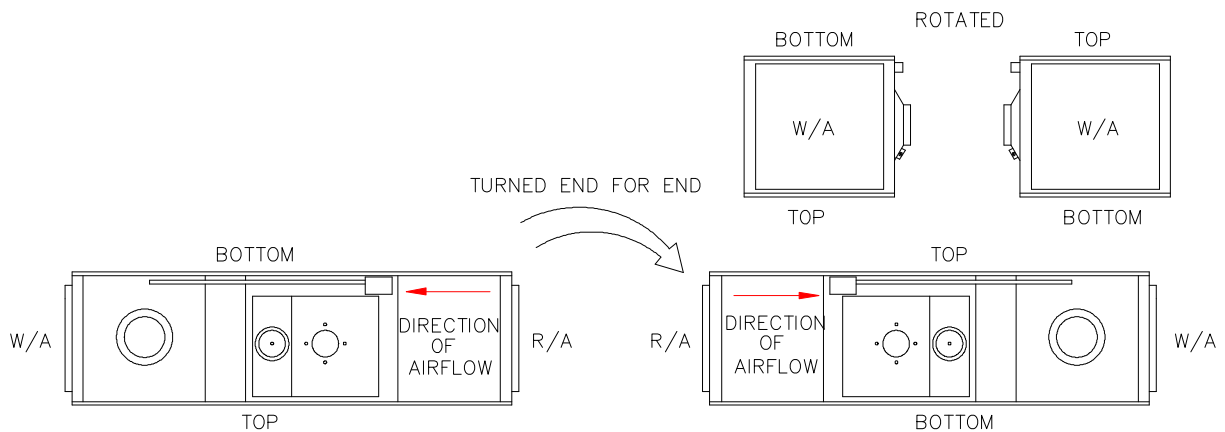

**Fig. 11: A horizontal furnace rotated 180° (or flipped end for end) to reverse airflow direction**

After the furnace has been positioned, the bottom burner mounting stud must be broken off before mounting the burner (See Fig. 12).

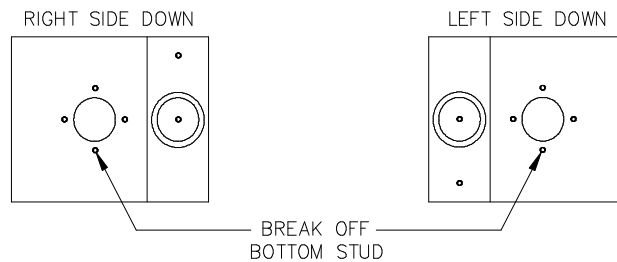

**Fig. 12: Required modification to burner mounting studs before burner installation**

### D. LIMIT POSITION AND LOCATION

**⚠WARNING:** The predetermined limit locations on all of the Thermo Pride oil fired furnaces have been tested and approved by Thermo Products, LLC. in conjunction with Underwriters Laboratories, Inc. Any attempt to relocate these safety controls or replace these safety controls with a control that is not approved, or is incompatible, may result in personal injury, substantial property damage or death.

#### **Limit connection for T11 & T16 Front Flue Models**

The T11 & T16 Front Flue furnaces only are shipped with two limits installed in the discharge air end of the furnace. After it has been determined in what direction the furnace will be installed, the correct limit will be connected to the limit harness.

**All installations and services must be performed by qualified service personnel.**

For the T11 or T16 Front Flue installed with the discharge air to the left (when facing burner, See fig 7A) The limit at the upper left of the furnace is to be used (T11=350264 160°F, T16=350817 150°F) Attach the harness to the limit cover from parts bag. Then connect the limit leads to the limit terminals. At this time the cover can be mounted to the cover the limit. The unused limit must now be removed. The opening that is left should be covered with the provided cover plate found in the parts bag.

For the T11 or T16 Front Flue installed with the discharge air to the right (when facing burner, see fig 7B ) the limit at the upper right of the furnace is to be used (T11=350953 120°F T16=350953 120°F) Attach the harness to the limit cover from parts bag. Then connect the limit leads to the limit terminals. At this time the cover can be mounted to cover the limit. The unused limit must now be removed. The opening that is left should be covered with the provided cover plate found in the parts bag.

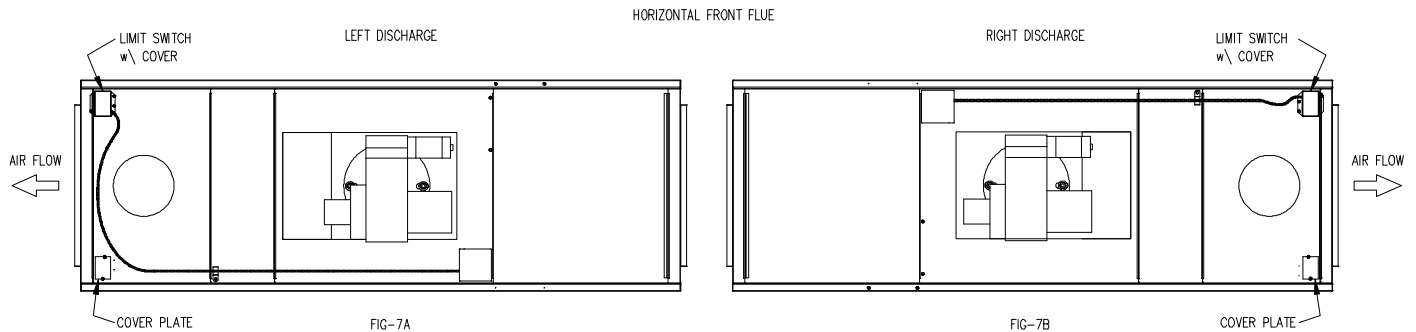

**Limit connection for T11 & T16 Rear Flue Models**

The T11 & T16 Rear Flue furnaces come prewired from the factory. No modifications are needed. See figures 7C- 7D below for limit locations.

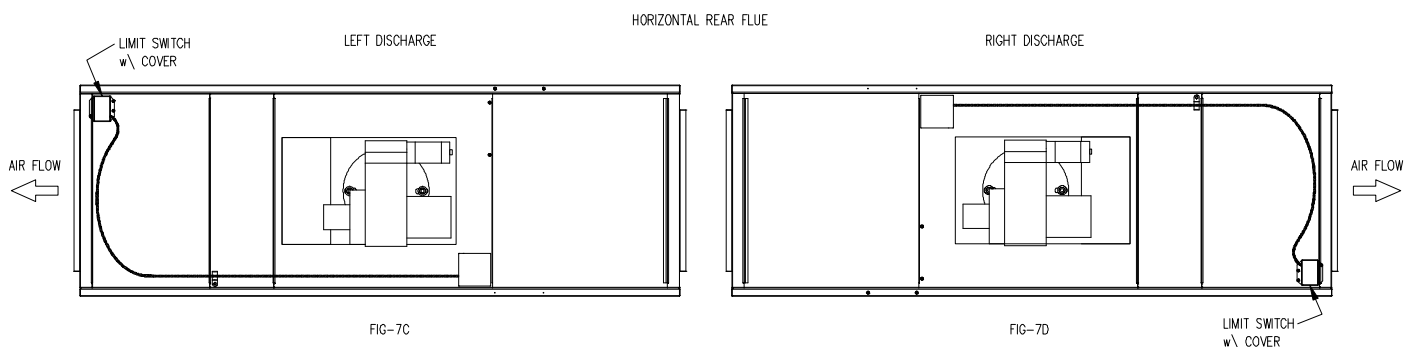

**E. BURNER INSTALLATION:**

**NOTICE:** Remove all cardboard packing from around chamber before installing burner.

The oil burner will mount on three stud mounting bolts on the lower mounting plate covering the opening in the front of the heat exchanger. The end of the burner tube should be inserted no further than 1/4 inch back from the inside surface of the combustion chamber. A distance further than 1/4 inch back from the inside chamber wall may cause impingement and sooting.

**NOTE: OVERFIRE AIR TAP MAY BE LOCATED ON EITHER SIDE OF FLAME INSPECTION COVER.** (See Fig. 8).

All installations and services must be performed by qualified service personnel.

### TWO PIECE MOUNTING PLATE

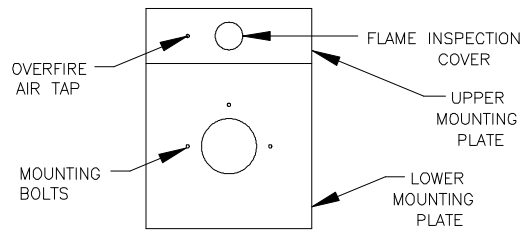

Fig. 8: Typical location of the overfire air tap

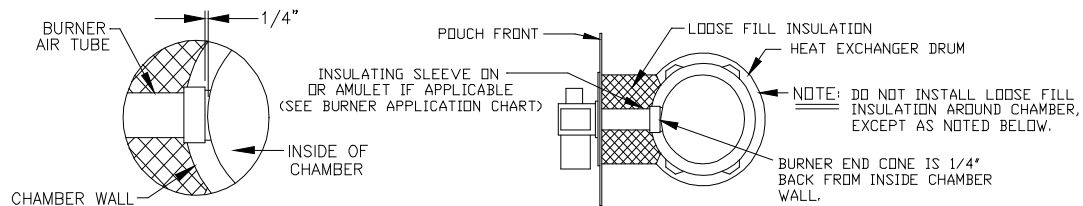

Fig. 9: (Top view) Burner insertion illustration

When mounting the burner, the upper mounting plate (Fig. 8) must be removed to provide access to the area in front of the combustion chamber. The combustion chamber can then be moved forward or backward slightly to allow for adjustment in positioning the burner tube. A fiber insulating sleeve or amulet is provided on the burner tube of specific Thermo Pride burners. (see Fig. 10). See Thermo Pride burner application chart for type of insulator. Do not allow the burner tube or end cone to physically touch or protrude into the chamber, as excess heat transfer could result in destruction of the tube, end cone or both. The burner tube/end cone is properly positioned, when the end is ¼ inch back from the inside surface of the combustion chamber wall.

**NOTE:** The loose-fill insulation that is included in a brown paper bag should be lightly placed around the burner tube between the front of the combustion chamber and the burner mounting plate. (DO NOT PACK THE INSULATION DOWN). The loose-fill insulation should be placed in such a fashion that the surface of the insulation is sloped from the top of the combustion chamber to the top of the lower mounting plate. The purpose of the loose insulation is to help protect the burner tube, mounting plates and vestibule area from excessive temperatures.

On the horizontal units, the loose-fill insulation will fall down around the side of the chamber (the chamber is on its side in horizontal units). This presents no problem to the unit, as the amount of insulation under the side will be minimal, but take care not to allow the insulation to fall into the open end of the chamber where it may burn and blow around, possibly lodging in the burner.

**NOTE:** Do not place loose insulation around chamber sides and back.

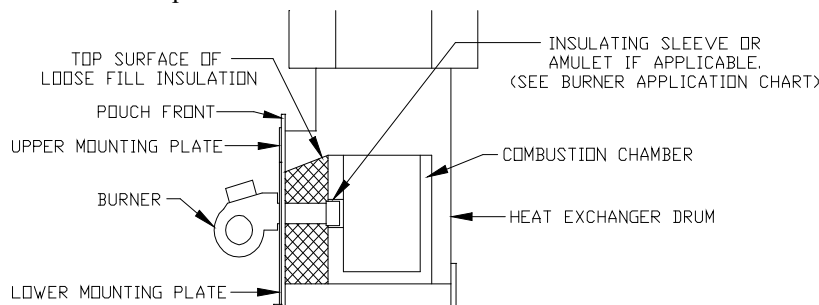
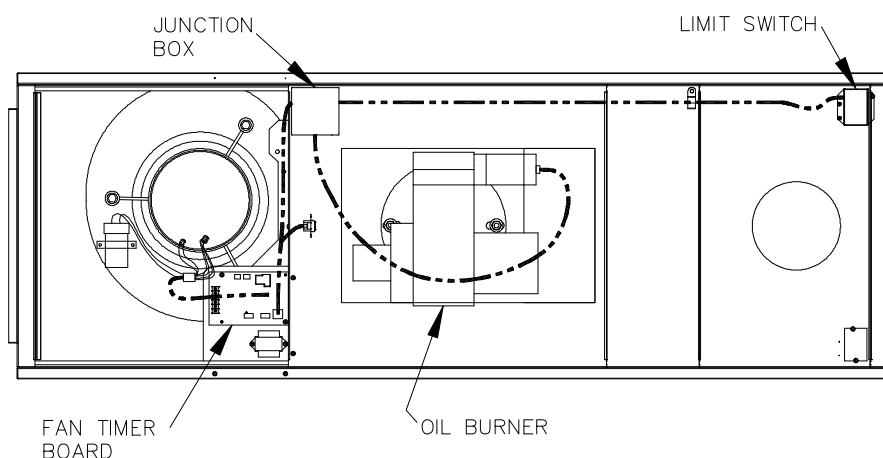

Fig. 10: (Side view) Burner insertion illustration

**All installations and services must be performed by qualified service personnel.**

## F. EXTERNAL WIRE HARNESS LOCATION

A Horizontal furnace is shown below with external wire harness and fan timer board configuration (blower access panel removed). (See Fig. 14).



**Fig. 14: The wiring system of a typical horizontal furnace**

## G. BURNER SPECIFICATIONS AND APPLICATIONS

### THERMO PRIDE BECKETT BURNER APPLICATION

FURNACE MODEL	THERMO PRIDE'S BURNER SPEC NO.	* INS	BECKETT BURNER MODEL & TUBE LENGTH	HEAD	STATIC PLATE	MAXIMUM NOZZLE SIZE**	SHIPPED NOZZLE SIZE	OIL PUMP PRESSURE (PSIG)	APPROX AIR SETTINGS
OL5-85	TP-1011	S	AFG 7-3/4	F3	2-3/4	0.75X80H	0.75X80H	100	S-7/B-0
OL11-105	TP-1011	S	AFG 7-3/4	F3	2-3/4	0.90X80H	0.90X80H	100	S-7/B-0
OL16-125	TP-1021	S	AFG 7-3/4	F6	2-3/4	1.25X80H	1.10X80H	100	S-7/B-0
OT11-105	TP-1011	S	AFG 7-3/4	F3	2-3/4	0.90X80H	0.90X80H	100	S-7/B-0
OT16-125	TP-1021	S	AFG 7-3/4	F6	2-3/4	1.25X80H	1.10X80H	100	S-7/B-0

### THERMO PRIDE RIELLO BURNER APPLICATION

The optional Riello Oil Burners listed below have been UL listed (UL file# MP3252) for applications on the following Thermo Pride furnaces.

FURNACE MODEL	THERMO PRIDE'S BURNER SPEC NO.	INS*	RIELLO BURNER MODEL & TUBE LENGTH	HEAD	STATIC PLATE	MAXIMUM NOZZLE SIZE**	SHIPPED NOZZLE SIZE	OIL PUMP PRESSURE (PSIG)	TURBULATOR SETTING	AIR DAMPER SETTING
OL5-85	380215	N	F3, 6"	N/A	N/A	.60 X 60°H	.60 X 60°H	145	1.5	3.4
OL11-105	380216	N	F5, 6"	N/A	N/A	.75 X 60°H	.75 X 60°H	145	1.5	2.2
OL16-125	380216	N	F5, 6"	N/A	N/A	.90 X 60°H	.90 X 60°H	145	2.0	2.6
OT11-105	380216	N	F5, 6"	N/A	N/A	.75 X 60°H	.75 X 60°H	145	1.5	2.2
OT16-125	380216	N	F5, 6"	N/A	N/A	.90 X 60°H	.90 X 60°H	145	2.0	2.6

\* Insulator S = sleeve or N = none

\*\* Maximum nozzle size for UL listing of furnace. The nozzle size gives the nominal flowrate, in GPH, followed by the spray angle, in degree's, and the spray pattern, either "H" for hollow cone or "S" for solid cone. For example, a nozzle rated at 0.65 GPH @ 100 PSIG that provides an 80° spray angle and a hollow spray pattern would be abbreviated in the table as "0.65 x 80H". Note: The reason the Riello burner nozzle sizes are smaller than the standard Thermo Pride Beckett burner nozzles is that pre-set pump pressures are higher, therefore achieving the same firing rate with a smaller nozzle.

Refer to furnace rating label for heating capacities.

**All installations and services must be performed by qualified service personnel.**

For more specific burner information, contact Thermo Products, LLC. P.O. Box 217, North Judson, IN 46366. Phone 574-896-2133.

For more specific Riello burner information, specifications or service information, reference the training manual enclosed with each Riello burner or contact: Riello Corporation of America,  
5 Pond Park Road  
Hingham, Massachusetts 02043  
(617) 749-8292

**H. HEAT EXCHANGER CLEANING INSTRUCTIONS:**

**⚠WARNING: THE HEAT EXCHANGER MUST BE CLEANED BY A QUALIFIED SERVICE PERSON.**

It is important to inspect and clean the heat exchanger once a year, or as necessary, to remove any build-up of soot. A layer of soot on the inside of the heat exchanger will act as an insulator and reduce heat transfer, resulting in less efficiency.

To clean the heat exchanger, first turn off all power to the unit. Next, remove the access panel (see below and beginning of following page) immediately above the burner (on the horizontal furnace, it will be located to the side of the burner) to gain entry to the clean-out covers, refer to figure 15. **This panel is identified with a label.** Remove clean-out covers, the vent connector pipe to the chimney, the burner, and the burner mounting plates. When removing the clean-out covers, special care must be taken not to damage the gaskets. Should the gaskets separate, crack, break, or be unsuitable for reuse, the gasket must be replaced before reattaching the clean-out covers.

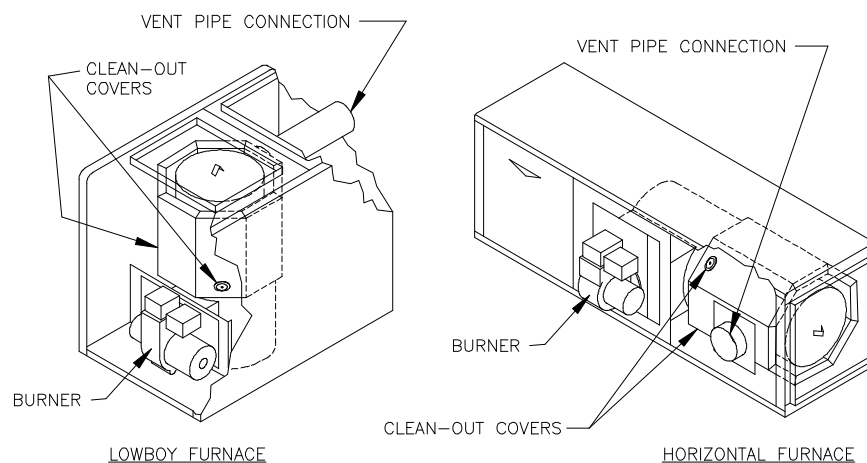
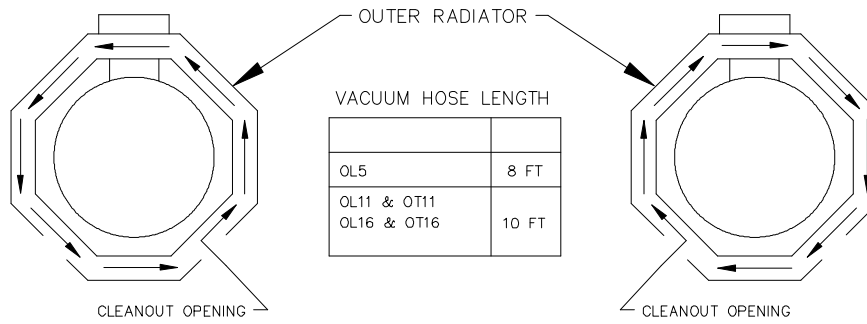

**Fig. 15: Typical Heat Exchanger Cleanout Cover Locations.**

With access to the inside of the heat exchanger through the burner area, clean-out openings, and vent pipe connection, it is possible to use a long, flexible wire brush and an industrial type vacuum cleaner to remove any soot build-up. **NOTE:** A one inch (outside diameter) vacuum cleaner hose will fit into the radiator.

**All installations and services must be performed by qualified service personnel.**

To vacuum and brush the outer radiator of the heat exchanger, go through the clean-out openings in both directions, as shown in figure 16, below.



**Fig. 16: Recommended method and device for cleaning inside of heat exchanger.**

Reassemble the furnace to its original construction. Remount the burner being certain that the air tube is properly inserted into the chamber opening (see section E). If heavy soot deposits were found in the heat exchanger, this may indicate the burner is out of adjustment.

**All installations and services must be performed by qualified service personnel.**

### **III. USERS INFORMATION SECTION**

**A. OIL SUPPLY:** Do not allow the fuel tank to run completely empty. During the summer, keep the tank full to prevent condensation of moisture on the inside surface of the tank. If the fuel tank runs completely dry, it may be necessary to purge the lines of trapped air. Contact a qualified technician to bleed the lines and restart the burner.

**OIL SUPPLY VALVE:** Turn the oil supply valve off if the burner is shut down for an extended period of time.

**B. COMBUSTION AIR SUPPLY:** The burner requires a generous amount of clean combustion air to operate safely. Lack of adequate combustion air can result in erratic operation of the burner, noisy combustion, or fuel odors in the air. NEVER BLOCK THE FURNACE FROM THE SUPPLY OF COMBUSTION AIR. If there is an exhaust fan, dryer or return air grill in the furnace room, there should be increased concern and additional efforts may be required to provide adequate combustion oil to the furnace at all times.

### **C. INSPECTION AREAS**

**VESTIBULE:** The furnace vestibule area or burner compartment should be inspected by removing the front door of the furnace and looking for signs of excessive heat such as discoloration of components materials damage, from rust or corrosion, soot or carbon build-up.

**EXTERIOR OF FURNACE:** The furnace exterior should be inspected for signs of excessive heat such as discoloration of materials and damage from rust or corrosion.

**FLUE PIPE, VENT PIPE OR CONNECTOR:** The furnace vent pipe should be inspected for signs of rust, corrosion pitting or holes in pipe, and leakage around seams in pipe, indicated by soot or condensate streaks.

**CHIMNEY OR VENTING SYSTEM:** The furnace venting system should be inspected for signs of rust, corrosion pitting or holes, and signs of condensation or moisture leakage from the venting system.

If any of the above symptoms are evident, call a qualified heating contractor for assistance.

**⚠CAUTION: DO NOT ATTEMPT TO MAKE REPAIRS YOURSELF!**

**⚠WARNING: The area around the furnace should be kept free and clear of combustible liquids and material, especially papers and rags.**

**⚠WARNING: NEVER burn garbage or refuse in your furnace. Never try to ignite oil by tossing burning papers or other material into your furnace.**

**⚠WARNING: Thermo Pride oil furnaces are designed to burn No. 1 or No. 2 distillate fuel oil. NEVER USE GASOLINE OR A MIXTURE OF OIL AND GASOLINE. A Bio-fuel mixture may be used but the mixture is not to exceed a B5.**

**⚠CAUTION: DO NOT ATTEMPT TO START THE BURNER WHEN:**

- 1. Excess oil has accumulated,**
- 2. The furnace is full of vapors**
- 3. The combustion chamber is very hot.**

**IF ONE OR MORE OF THESE CONDITIONS EXIST, CONTACT A QUALIFIED SERVICE PERSON.**

### **D. STARTING THE BURNER:**

1. Turn the main service switch to "OFF" position.
2. Set thermostat substantially above room temperature.
3. Open shut-off valves in oil supply line to burner.
4. Turn service switch to furnace "ON". If burner starts and runs, but stops again on lockout, it may be necessary to bleed the lines or make burner combustion air adjustments. Contact a qualified service person to adjust and start burner.



**All installations and services must be performed by qualified service personnel.**

**E. FILTER CLEANING AND LOCATION:**

The air filters should be inspected each month and cleaned when dirty. Cleaning the air filters frequently may reduce airborne contaminants from entering the furnace and depositing in the furnace, duct system and home.

**⚠WARNING: To avoid injury from moving parts, hot surfaces, or electrical shock, shut off the power to the furnace before removing any furnace access doors to service the air filters.**

To clean a dirty filter, first remove the blower compartment door at the rear of the furnace, refer to figure 17. Remove the dirty filter from the filter rack and clean it with a mild soap and water solution. Make sure filter is thoroughly dry before replacing. Replace the blower compartment door.

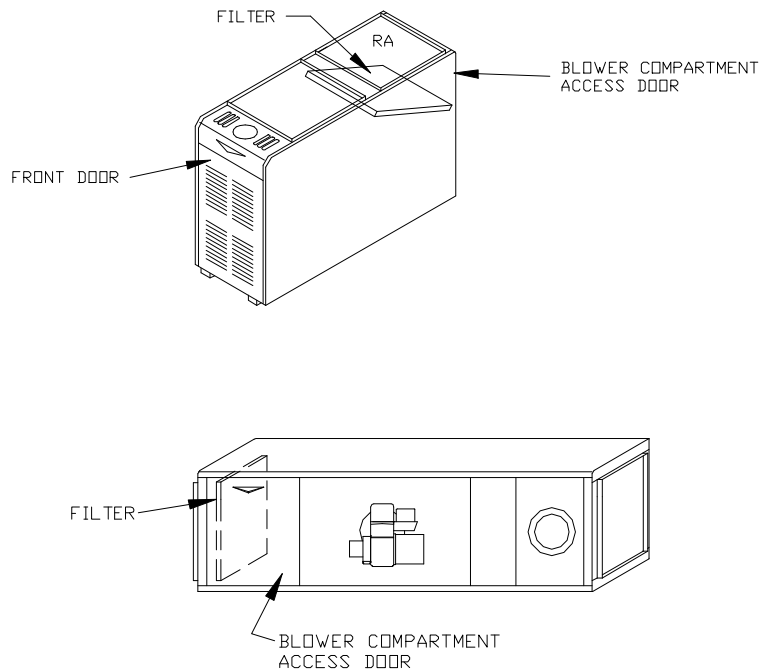

**Fig. 17**

**Location of the air filter and blower compartment access door on the typical lowboy & horizontal furnace.**

**All installations and services must be performed by qualified service personnel.**

**COMBUSTION AND EFFICIENCY TESTING FOR THERMO PRIDE OIL FIRED CENTRAL FURNACES.**

Complete this form for each Thermo Pride furnace installed. Read instruction manual carefully before making tests. Retain this form with furnace.

<b>CUSTOMER</b>	NAME				
	ADDRESS				
	CITY, STATE				
<b>HEATING SYSTEM</b>	BURNER MODEL NO.	BLAST TUBE LGTH. INS.	AIR SHUTTER OPENING % OF MAX. (EST)		
	COMBUSTION CHAMBER	CONDITION	MATERIAL	FURNACE MODEL	
	TYPE OF VENTING SYSTEM				
	<input type="checkbox"/> MASONRY CHIMNEY	<input type="checkbox"/> METAL CHIMNEY	<input type="checkbox"/> SIDEWALL POWER VENTER	<input type="checkbox"/> MASONRY CHIMNEY W/INDUCER	
	<input type="checkbox"/> METAL CHIMNEY W/INDUCER	<input type="checkbox"/> MASONRY CHIMNEY W/METAL LINER			
FUEL LINE FILTER	DRAFT CONTROL		FURNACE SERIAL NUMBER		
<b>COMBUSTION TESTS</b>  (Operate burner at least 10 minutes before starting tests.)		INITIAL INSTALLATION	SERVICE	SERVICE	SERVICE
	CO2 in stack pipe				
	Draft Over-fire				
	Draft in stack pipe				
	Smoke number				
	Gross stack temp.				
	Furnace room temp.				
	Net stack temp. (Gross stack minus furnace room temp.)				
	Efficiency				
	Nozzle size and spray				
	Oil pump pressure				
	Operation of Controls				
	Burner Safety Controls				
	Check for oil leaks				
	Tests taken by				
	Date				
	NOTES:				
	INSTALLER NAME & ADDRESS				

**All installations and services must be performed by qualified service personnel.**

**APPENDIX-A Replacement Parts List**

OL5-85FDBP, OL11-105FDBP, OL16-125FDBP, OL11-105FD BE, OL16-125FD BE  
 OL5-85RDBP, OL11-105RDBP, OL16-125RDBP, OL11-105RD BE, OL16-125RD BE

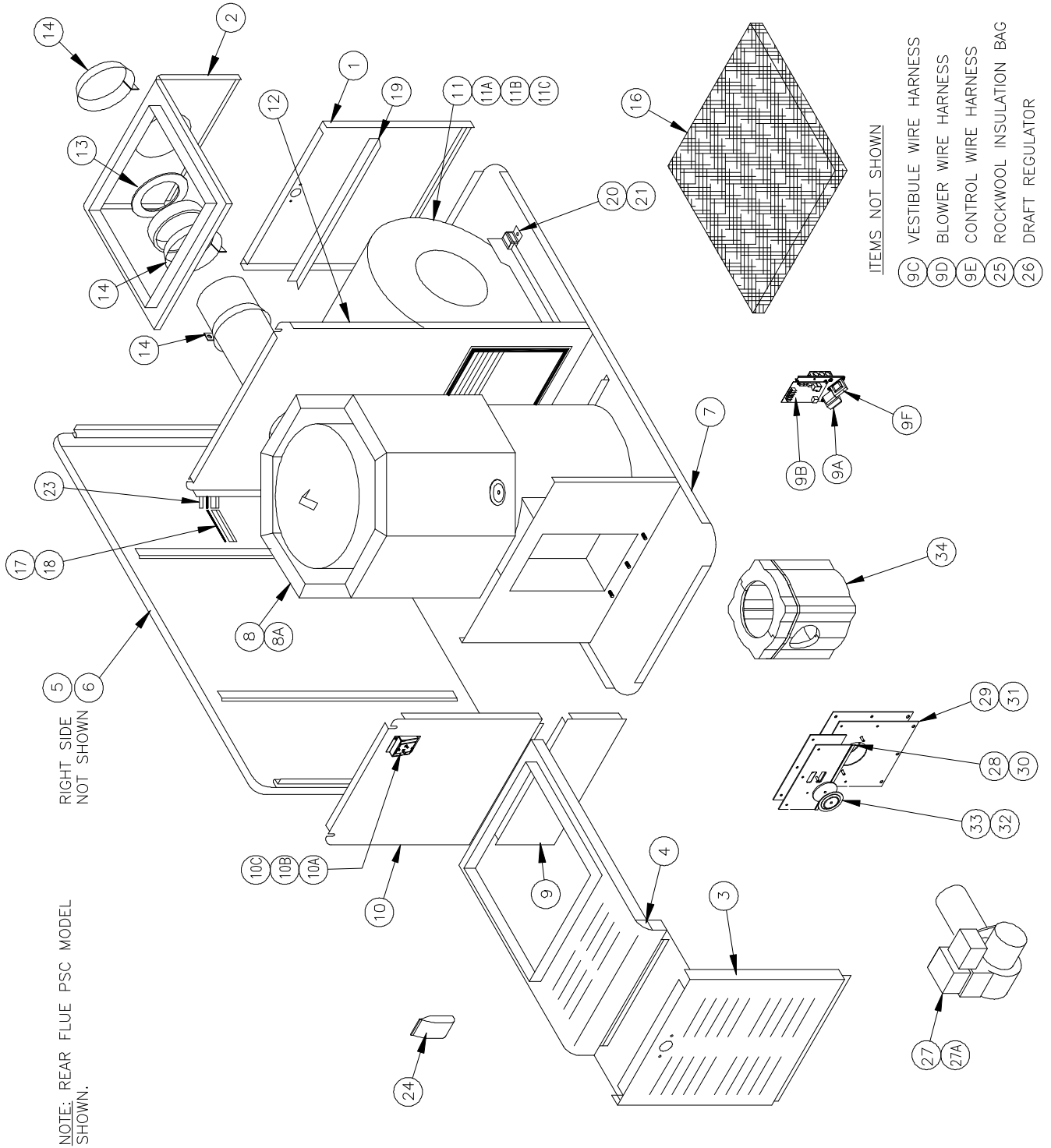

**All installations and services must be performed by qualified service personnel.**

ITEM	PARTS DESCRIPTION	UNIT	OL5-85FDBP		OL11-105FDBP		OL16-125FDBP		OL11-105FDBE		OL16-125FDBE	
			PART NO.	QTY.	PART NO.	QTY.	PART NO.	QTY.	PART NO.	QTY.	PART NO.	QTY.
1	BLOWER ACCESS DOOR		620408	1	620414	1	620420	1	620414	1	620420	1
2	TOP REAR SECTION		620410	1	620416	1	620422	1	620416	1	620422	1
3	FRONT DOOR		620407	1	620413	1	620419	1	620413	1	620419	1
4	TOP FRONT SECTION		620409	1	620415	1	620421	1	620415	1	620421	1
5	SIDE CASING (LEFT)		620002	1	620004	1	620008	1	620004	1	620008	1
6	SIDE CASING (RIGHT)		620003	1	620005	1	620009	1	620005	1	620009	1
7	BASE		20454	1	20455	1	20466	1	20455	1	20466	1
8	HEAT EXCHANGER		31459	1	31471	1	31486	1	31471	1	31486	1
8A	HX CLEANOUT COVER KIT		AOPS7586	1	AOPS7586	1	AOPS7586	1	AOPS7586	1	AOPS7586	1
9	FRONT CENTER PANEL		621030	1	621037	1	621047	1	621037	1	621047	1
9A	TRANSFORMER		350464	1	350464	1	350464	1	350464	1	350464	1
9B	FURNACE CONTROL		AOPS8380	1	AOPS8380	1	AOPS8380	1	AOPS8381	1	AOPS8381	1
9C	WIRE HARNESS, VESTIBULE		350271	1	350271	1	350271	1	350271	1	350271	1
9D	WIRE HARNESS, BLOWER		350270	1	350270	1	350270	1	350918	1	350918	1
9E	WIRE HARNESS, CONTROL		-	-	-	-	-	-	350921	1	350921	1
9F	INDUCTOR		-	-	-	-	-	-	-	-	350855	1
10	FRONT TOP SEPARATOR		619158	1	619160	1	619162	1	619160	1	619162	1
10A	LIMIT BRACKET		29156	1	29156	1	29156	1	29156	1	29156	1
10B	LIMIT SWITCH		350103	1	350103	1	350273	1	350103	1	350273	1
10C	INSULATOR BOOT		350036	1	350036	1	350036	1	350036	1	350036	1
11	BLOWER ASSEMBLY		S00S4231	1	S00S4231	1	S00S4215	1	S00S4148	1	S00S4160	1
11A	BLOWER HOUSING w\ WHEEL		S00S4143	1	S00S4143	1	S00S4143	1	S00S4143	1	S00S4143	1
11B	MOTOR		AOPS7657	1	AOPS7657	1	AOPS7653	1	AOPS7446	1	AOPS7472	1
11C	MOTOR MOUNTING BRACKET		AOPS7670	1	AOPS7670	1	AOPS7670	1	AOPS7670	1	AOPS7670	1
12	REAR SEPARATOR		21033	1	21036	1	21042	1	21036	1	21042	1
13	FLUE COLLAR GASKET		330005	1	330005	1	330006	1	330005	1	330006	1
14	DRAW COLLAR		14131	1	14131	1	14132	1	14131	1	14132	1
15	FLUE ELBOW		35719	1	35719	1	35721	1	35719	1	35721	1
16	FILTER		370022	1	370035	1	370036	2	370035	1	370036	2
17	FILTER SUPPORT (LEFT)		624712	1	624719	1	624721	1	624719	1	624721	1
18	FILTER SUPPORT (RIGHT)		624713	1	624720	1	624722	1	624720	1	624722	1
19	REAR FILTER SUPPORT		614715	1	614715	1	614726	1	614715	1	614726	1
20	BLOWER HOLD DOWN		14113	1	14113	1	14113	1	14113	1	14113	1
21	BLOWER HOLD DOWN		14114	1	14114	1	14114	1	14114	1	14114	1
22	FLUE BACKING PLATE GASKET		330008	1	330008	1	330023	1	330008	1	330023	1
23	CENTER FILTER SUPPORT		-	-	-	-	614724	1	-	-	614724	1
24	DOOR HANDLE PKG (2 SETS)		320152	1	320152	1	320152	1	320152	1	320152	1
25	ROCK WOOL INSUL PKG		AOPS7575	1	AOPS7575	1	AOPS7575	1	AOPS7575	1	AOPS7575	1
26	DRAFT REGULATOR		370105	1	370105	1	370106	1	370105	1	370106	1
27	BURNER AFG		350737	1	350737	1	350738	1	350737	1	350738	1
27A	NOZZLE		380366	1	380367	1	380369	1	380367	1	380369	1
28	TOP MTG PLATE		25716	1	25716	1	25716	1	25716	1	25716	1
29	BOTTOM MTG PLATE		25717	1	25717	1	25717	1	25717	1	25717	1
30	TOP MTG PLATE GASKET		330055	1	330055	1	330055	1	330055	1	330055	1
31	BOTTOM MTG PLATE GASKET		330056	1	330056	1	330056	1	330056	1	330056	1
32	4" INSPECTION GASKET		330009	1	330009	1	330009	1	330009	1	330009	1
33	INSPECTION COVER		15794	1	15794	1	15794	1	15794	1	15794	1
34	CHAMBER		AOPS7323	1	AOPS7323	1	AOPS7324	1	AOPS7323	1	AOPS7324	1

**All installations and services must be performed by qualified service personnel.**

ITEM	PARTS DESCRIPTION	UNIT		OL5-85RDBP		OL11-105RDBP		OL16-125RDBP		OL11-105RDBE		OL16-125RDBE	
		PART NO.	QTY.	PART NO.	QTY.	PART NO.	QTY.	PART NO.	QTY.	PART NO.	QTY.	PART NO.	QTY.
1	BLOWER ACCESS DOOR	620408	1	620414	1	620420	1	620414	1	620420	1		
2	TOP REAR SECTION	620412	1	620418	1	620424	1	620418	1	620424	1		
3	FRONT DOOR	620407	1	620413	1	620419	1	620413	1	620419	1		
4	TOP FRONT SECTION	620411	1	620417	1	620423	1	620417	1	620423	1		
5	SIDE CASING (LEFT)	620002	1	620004	1	620008	1	620004	1	620008	1		
6	SIDE CASING (RIGHT)	620003	1	620005	1	620009	1	620005	1	620009	1		
7	BASE	20454	1	20455	1	20466	1	20455	1	20466	1		
8	HEAT EXCHANGER	31458	1	31470	1	31485	1	31470	1	31485	1		
8A	HX CLEANOUT COVER KIT	AOPS7586	1	AOPS7586	1	AOPS7586	1	AOPS7586	1	AOPS7586	1		
9	FRONT CENTER PANEL	621030	1	611040	1	621047	1	611040	1	621047	1		
9A	TRANSFORMER	350464	1	350464	1	350464	1	350464	1	350464	1		
9B	FURNACE CONTROL	AOPS8380	1	AOPS8380	1	AOPS8380	1	AOPS8381	1	AOPS8381	1		
9C	WIRE HARNESS, VESTIBULE	350271	1	350271	1	350271	1	350271	1	350271	1		
9D	WIRE HARNESS, BLOWER	350270	1	350270	1	350270	1	350918	1	350918	1		
9E	WIRE HARNESS, CONTROL	-	-	-	-	-	-	350921	1	350921	1		
9F	INDUCTOR	-	-	-	-	-	-	-	-	350855	1		
10	FRONT TOP SEPARATOR	619161	1	619161	1	619163	1	619161	1	619163	1		
10A	LIMIT BRACKET	29156	1	29156	1	29156	1	29156	1	29156	1		
10B	LIMIT SWITCH	350103	1	350103	1	19155	1	350103	1	19155	1		
10C	INSULATOR BOOT	350036	1	350036	1	350036	1	350036	1	350036	1		
11	BLOWER ASSEMBLY	S00S4231	1	S00S4231	1	S00S4215	1	S00S4148	1	S00S4160	1		
11A	BLOWER HOUSING w\ WHEEL	S00S4143	1	S00S4143	1	S00S4143	1	S00S4143	1	S00S4143	1		
11B	MOTOR	AOPS7657	1	AOPS7657	1	AOPS7653	1	AOPS7446	1	AOPS7472	1		
11C	MOTOR MOUNTING BRACKET	AOPS7670	1	AOPS7670	1	AOPS7670	1	AOPS7670	1	AOPS7670	1		
12	REAR SEPARATOR	21034	1	21038	1	21045	1	21038	1	21042	1		
13	FLUE COLLAR GASKET	330005	1	330005	1	330006	1	330005	1	330006	1		
14	DRAW COLLAR	14131	3	14131	3	14132	3	14131	3	14132	3		
15	-	-	-	-	-	-	-	-	-	-	-		
16	FILTER	370022	1	370035	1	370036	2	370035	1	370036	2		
17	FILTER SUPPORT (LEFT)	624712	1	624719	1	624721	1	624719	1	624721	1		
18	FILTER SUPPORT (RIGHT)	624713	1	624720	1	624722	1	624720	1	624722	1		
19	REAR FILTER SUPPORT	614715	1	614715	1	614726	1	614715	1	614726	1		
20	BLOWER HOLD DOWN	14113	1	14113	1	14113	1	14113	1	14113	1		
21	BLOWER HOLD DOWN	14114	1	14114	1	14114	1	14114	1	14114	1		
22	-	-	-	-	-	-	-	-	-	-	-		
23	CENTER FILTER SUPPORT	-	-	-	-	614724	1	-	-	614724	1		
24	DOOR HANDLE PKG (2 SETS)	320152	1	320152	1	320152	1	320152	1	320152	1		
25	ROCK WOOL INSUL PKG	AOPS7575	1	AOPS7575	1	AOPS7575	1	AOPS7575	1	AOPS7575	1		
26	DRAFT REGULATOR	370105	1	370105	1	370106	1	370105	1	370106	1		
27	BURNER AFG	350737	1	350737	1	350738	1	350737	1	350738	1		
27A	NOZZLE	380366	1	380367	1	380369	1	380367	1	380369	1		
28	TOP MTG PLATE	25716	1	25716	1	25716	1	25716	1	25716	1		
29	BOTTOM MTG PLATE	25717	1	25717	1	25717	1	25717	1	25717	1		
30	TOP MTG PLATE GASKET	330055	1	330055	1	330055	1	330055	1	330055	1		
31	BOTTOM MTG PLATE GASKET	330056	1	330056	1	330056	1	330056	1	330056	1		
32	4" INSPECTION GASKET	330009	1	330009	1	330009	1	330009	1	330009	1		
33	INSPECTION COVER	15794	1	15794	1	15794	1	15794	1	15794	1		
34	CHAMBER	AOPS7323	1	AOPS7323	1	AOPS7324	1	AOPS7323	1	AOPS7324	1		

**All installations and services must be performed by qualified service personnel.**

OT11-105FBP & , OT16-125FBP

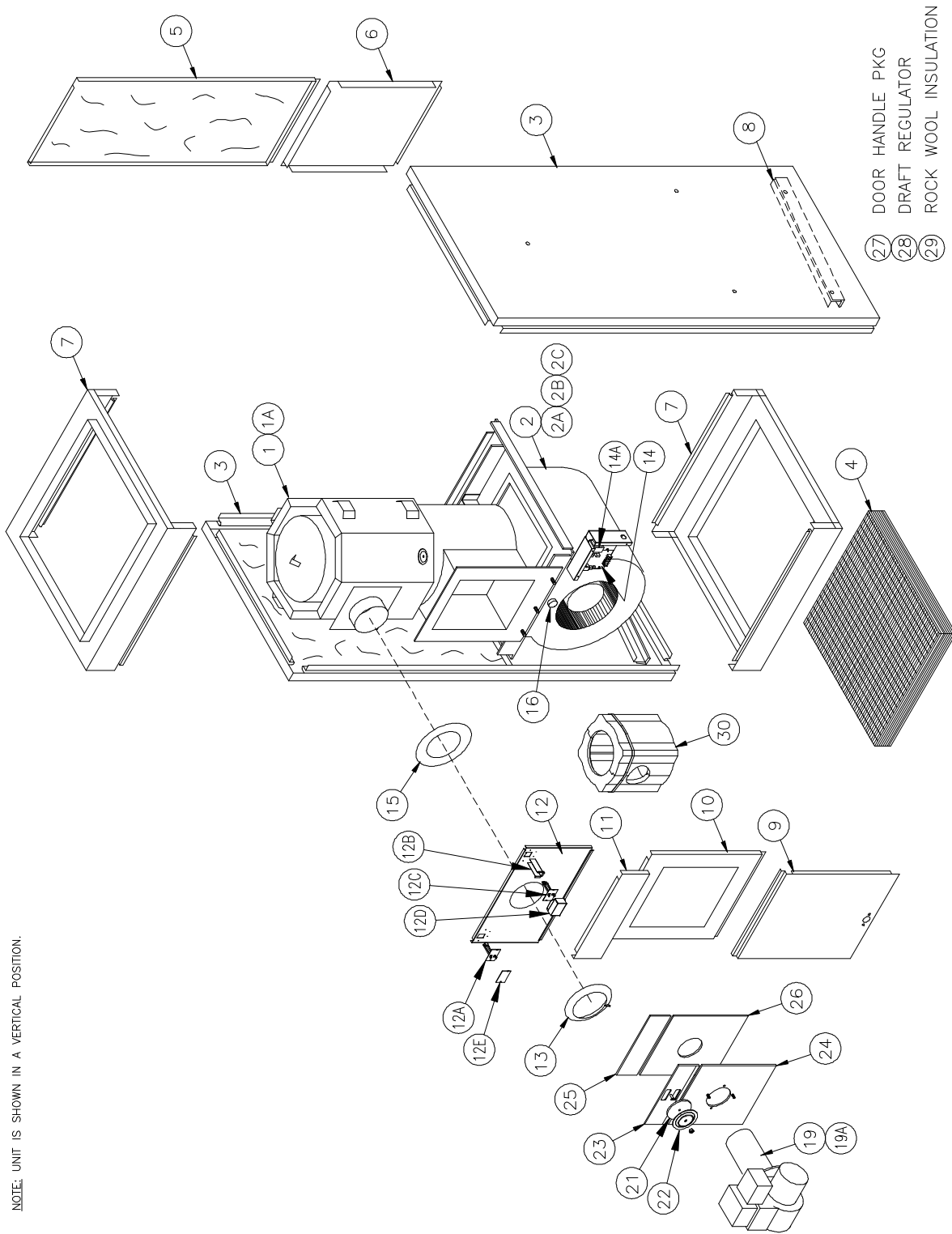

NOTE: UNIT IS SHOWN IN A VERTICAL POSITION.

**All installations and services must be performed by qualified service personnel.**

ITEM	PARTS DESCRIPTION	UNIT	OT11-105FBP		OT16-125FBP	
			PART NO.	QTY.	PART NO.	QTY.
1	HEAT EXCHANGER ASSEMBLY		31598	1	31601	1
1A	HX CLEANOUT COVER KIT		AOPS7586	1	AOPS7586	1
2	BLOWER ASSEMBLY		S00S4228	1	S00S4229	1
2A	BLOWER HSG w\ WHEEL		S00S4143	1	340039	1
2B	MOTOR w\ CAPACITOR		AOPS7657	1	AOPS7653	1
2C	MOTOR MOUNTING BRACKET		AOPS7670	1	AOPS7670	1
3	SIDE CASING (LEFT & RIGHT)		620049	2	620032-1	2
4	FILTER		370051	1	370051	1
5	REAR TOP PANEL		610505	1	610514-1	1
6	REAR BOTTOM PANEL		610503	1	610512-1	1
7	END CAP (INTAKE & EXHAUST)		620499	2	620508-1	2
8	FILTER SUPPORT		614752	2	614753-1	2
9	BLOWER ACCESS DOOR		620500	1	620509-1	1
10	FRONT CENTER PANEL		610501	1	610510-1	1
11	FRONT REMOVABLE PANEL		610502	1	610511-1	1
12	FRONT TOP PANEL		619164	1	619152-7	1
12A	LIMIT SWITCH (TOP LEFT)		350953	1	350953	1
12B	LIMIT SHIELD		19144	1	19144	1
12C	LIMIT SWITCH (TOP RIGHT)		350264	1	350817	1
12D	LIMIT COVER		19146	1	19146	1
12E	COVER PLATE		619157	1	619157	1
13	DRAW COLLAR		14131	1	14132	1
14	OIL FURNACE CONTROL		AOPS8380	1	AOPS8380	1
14A	TRANSFORMER		350464	1	350464	1
14B	WIRE HARNESS, BLOWER		350266	1	350266	1
14C	WIRE HARNESS, MAIN		350272	1	350272	1
15	FLUE GASKET		330005	1	330006	1
16	AUX LIMIT SWITCH		350263	1	350263	1
19	OIL BURNER, BECKETT AFG		380737	1	380738	1
19A	NOZZLE		380367	1	380369	1
21	4" INSPECTION GASKET		330009	1	330009	1
22	INSPECTION COVER		15794	1	15794	1
23	TOP MTG PLATE		25716	1	25716	1
24	BOTTOM MTG PLATE		25737	1	25737	1
25	TOP MTG PLATE GASKET		330055	1	330055	1
26	BOTTOM MTG PLATE GASKET		330056	1	330056	1
27	DOOR HANDLE PKG (1 SET)		AOPS7578	1	AOPS7578	1
28	DRAFT REGULATOR		370105	1	370106	1
29	ROCK WOOL INSULATION		AOPS7575	1	AOPS7575	1
30	CHAMBER		AOPS7323	1	AOPS7324	1

**All installations and services must be performed by qualified service personnel.**

OT11-105RBP & , OT16-125RBP

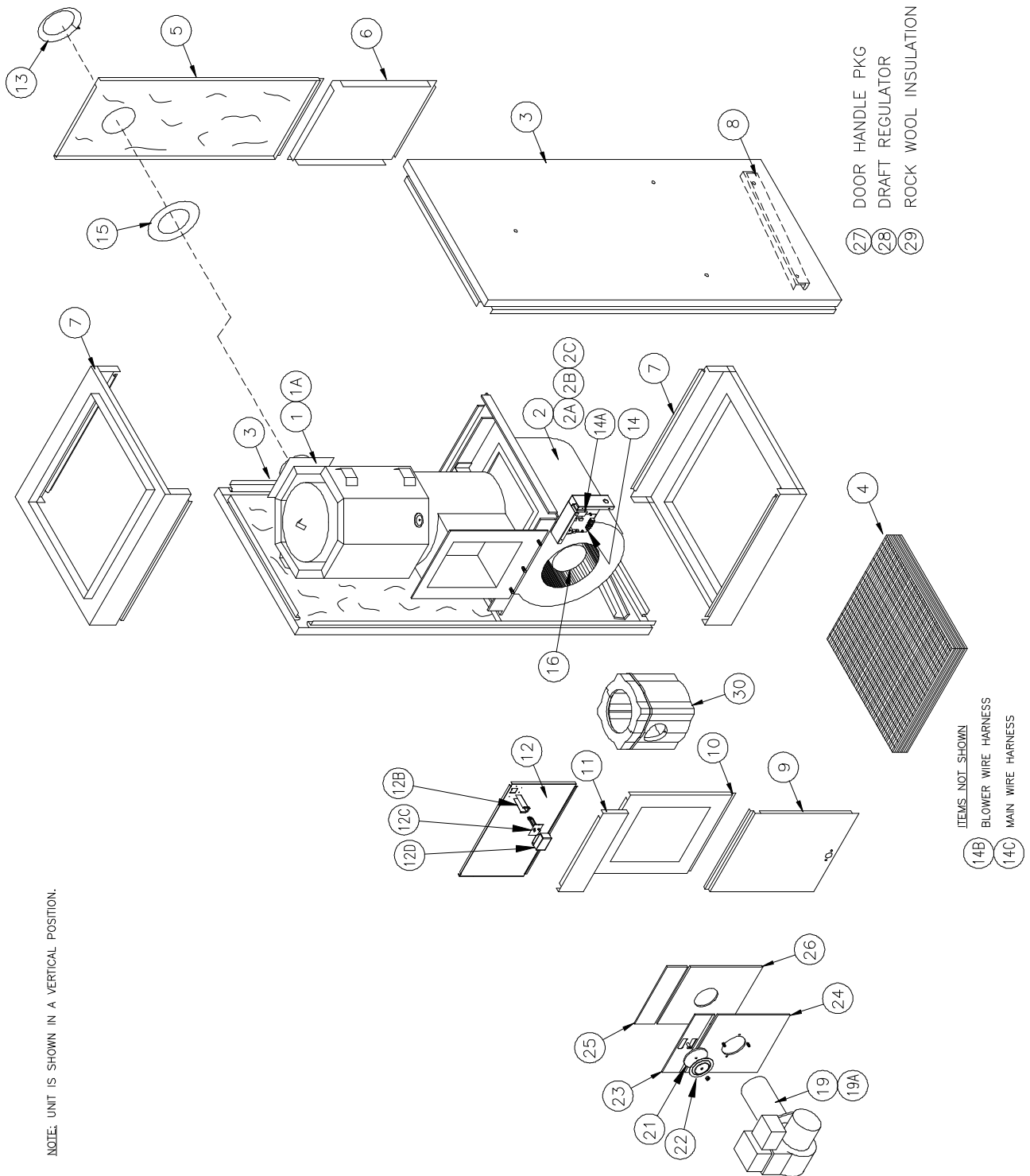

NOTE: UNIT IS SHOWN IN A VERTICAL POSITION.



**All installations and services must be performed by qualified service personnel.**

ITEM	PARTS DESCRIPTION	UNIT		OT11-105RBP		OT16-125RBP	
		PART NO.	QTY.	PART NO.	QTY.	PART NO.	QTY.
1	HEAT EXCHANGER ASSEMBLY	31599	1	31602	1		
1A	HX CLEANOUT COVER KIT	AOPS7586	1	AOPS7586	1		
2	BLOWER ASSEMBLY	S00S4228	1	S00S4229	1		
2A	BLOWER HSG w\ WHEEL	S00S4143	1	340039	1		
2B	MOTOR w\ CAPACITOR	AOPS7657	1	AOPS7653	1		
2C	MOTOR MOUNTING BRACKET	AOPS7670	1	AOPS7670	1		
3	SIDE CASING (LEFT & RIGHT)	620049	2	620032-1	2		
4	FILTER	370051	1	370051	1		
5	REAR TOP PANEL	610507	1	610516-1	1		
6	REAR BOTTOM PANEL	610503	1	610512-1	1		
7	END CAP (INTAKE & EXHAUST)	620499	2	620508-1	2		
8	FILTER SUPPORT	614752	2	614753-1	2		
9	BLOWER ACCESS DOOR	620500	1	620509-1	1		
10	FRONT CENTER PANEL	610501	1	610510-1	1		
11	FRONT REMOVABLE PANEL	610502	1	610511-1	1		
12	FRONT TOP PANEL	619165	1	619153-7	1		
12B	LIMIT SHIELD	19144	1	19144	1		
12C	LIMIT SWITCH (TOP RIGHT)	350264	1	350264	1		
12D	LIMIT COVER	19146	1	19146	1		
13	DRAW COLLAR	14131	1	14132	1		
14	OIL FURNACE CONTROL	AOPS8380	1	AOPS8380	1		
14A	TRANSFORMER	350464	1	350464	1		
14B	WIRE HARNESS, BLOWER	350266	1	350266	1		
14C	WIRE HARNESS, MAIN	350272	1	350272	1		
15	FLUE GASKET	330005	1	330006	1		
16	AUX LIMIT SWITCH	350263	1	350263	1		
19	OIL BURNER, BECKETT AFG	380737	1	380738	1		
19A	NOZZLE	380367	1	380369	1		
21	4" INSPECTION GASKET	330009	1	330009	1		
22	INSPECTION COVER	15794	1	15794	1		
23	TOP MTG PLATE	25716	1	25716	1		
24	BOTTOM MTG PLATE	25737	1	25737	1		
25	TOP MTG PLATE GASKET	330055	1	330055	1		
26	BOTTOM MTG PLATE GASKET	330056	1	330056	1		
27	DOOR HANDLE PKG (1 SET)	AOPS7578	1	AOPS7578	1		
28	DRAFT REGULATOR	370105	1	370106	1		
29	ROCK WOOL INSULATION	AOPS7575	1	AOPS7575	1		
30	CHAMBER	AOPS7323	1	AOPS7324	1		

All installations and services must be performed by qualified service personnel.

TP 1011 AFG BURNER PART# 380737

Replacement parts

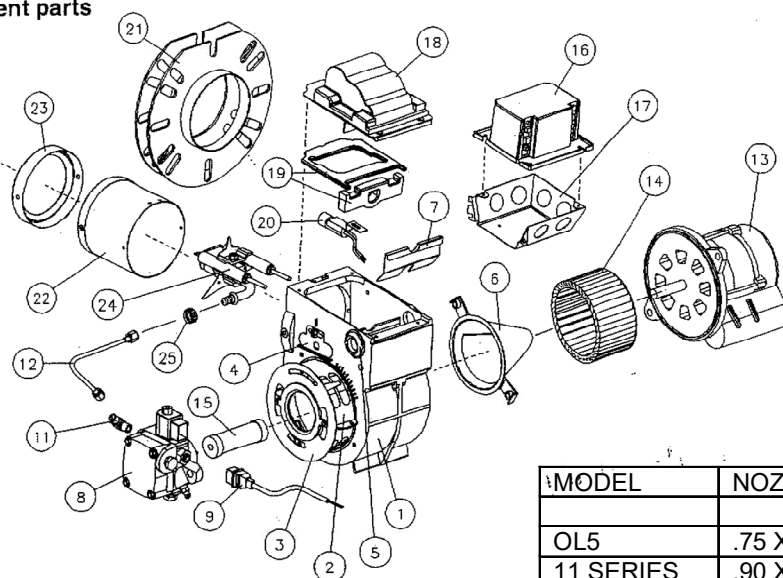

MODEL	NOZZLE SIZE	PART #
OL5	.75 X 80° A	380366
11 SERIES	.90 X 80° A	380367

ITEM	DESCRIPTION	BECKETT PART #	TP PART #
1	BURNER HOUSING ASSY.	5874MR	
2	AIR BAND ASSY. SETTING - 0	5151501	
3	AIR SHUTTER, SETTING - 7	3494	
4	ESCUTCHEON PLATE	3493	
	SCREW		
5	HOLE PLUG		
6	AIR GUIDE	31231U	
7	LOW FIRING RATE BAFFLE	5880	
8	*PUMP 100PSI	21844	380674
	*SOLENOID	21755	380654
9	VALVE CORD SET	21807	380653
11	PUMP ELBOW	2256	320815
12	CONNECTION TUBE	5394	380268
13	*MOTOR 1/7 HP 3450 RPM	21805E	380644
14	BLOWER WHEEL 4 1/4 X 2 7/16 TAB	2999	380271
15	COUPLING	2454	380241
16	*PRIMARY CONTROL R7184B	7456	350431
17	ELECTRICAL BOX	3741	
18	*IGNITER W/ GASKETS	51771U	380645
19	IGNITER GASKET KIT		
20	CAD CELL w/ Socket C554A1919	7006Q	350104
21	FLANGE	3634BK	380265
	GASKET	3616	380270
22	AIR TUBE COMBINATION	AF76XNOS	
	BLAST TUBE ONLY		380273
23	HEAD F3	360003	380260
	SLEEVE	31581	380242 / AOPS0511
24	ELECTRODE NOZZLE ASSY		380282
	*ELECTRODES PAIR	5780	380269
	STATIC PLATE, 2 3/4 U	3383	380330
25	SPLINED NUT(BULKHEAD NUT)	3666	320121
	BULK HEAD FITTING	3488	320120

All installations and services must be performed by qualified service personnel.

TP 1021 AFG BURNER PART# 380738

Replacement parts

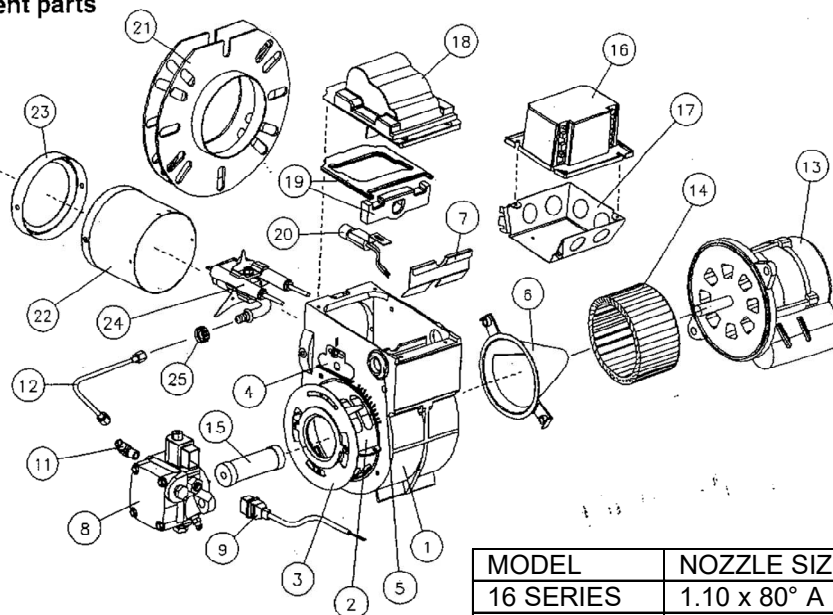

MODEL	NOZZLE SIZE	PART #
16 SERIES	1.10 x 80° A	380369

ITEM	DESCRIPTION	BECKETT PART #	TP PART #
1	BURNER HOUSING ASSY.	5874MR	
2	AIR BAND ASSY. SETTING - 0	5151501	
3	AIR SHUTTER, SETTING - 7	3494	
4	ESCUTCHEON PLATE	3493	
	SCREW		
5	HOLE PLUG		
6	AIR GUIDE	31231U	
7	LOW FIRING RATE BAFFLE	5880	
8	PUMP 100PSI	21844	380674
	SOLENOID	21755	380654
9	VALVE CORD SET	21807	380653
11	PUMP ELBOW	2256	320815
12	CONNECTION TUBE	5394	380268
13	MOTOR 1/7 HP 3450 RPM	21805E	380644
14	BLOWER WHEEL 4 1/4 X 2 7/16 TAB	2999	380271
15	COUPLING	2454	380241
16	PRIMARY CONTROL R7184B	7456	350431
17	ELECTRICAL BOX	5770	
18	IGNITER W/ GASKETS	51771U	380645
19	IGNITER GASKET KIT		
20	CAD CELL w/ Socket C554A1919	7006Q	350104
21	FLANGE	3634BK	380265
	GASKET	31653	380270
22	AIR TUBE COMBINATION	AF76YBOS	
	AIR TUBE ONLY		380273
23	HEAD F-6	360006	380261
	SLEEVE	31581	AOPS0511
24	ELECTRODE NOZZLE ASSY		380282
	ELECTRODES PAIR	5780	380269
	STATIC PLATE, 2 3/4 U	3383	380330
25	SPLINED NUT(BULKHEAD NUT)	3666	320121
	BULK HEAD FITTING	3488	320120

# All installations and services must be performed by qualified service personnel.

## APPENDIX-B Wiring Diagrams

### OL5-85\*DBP, OL11-105\*DBP, OL16-125\*DBP

## ELECTRICAL DIAGRAMS & OPERATING INSTRUCTIONS FOR LOWBOY OIL FURNACE

P/N WD-630  
ECN 5325AMA

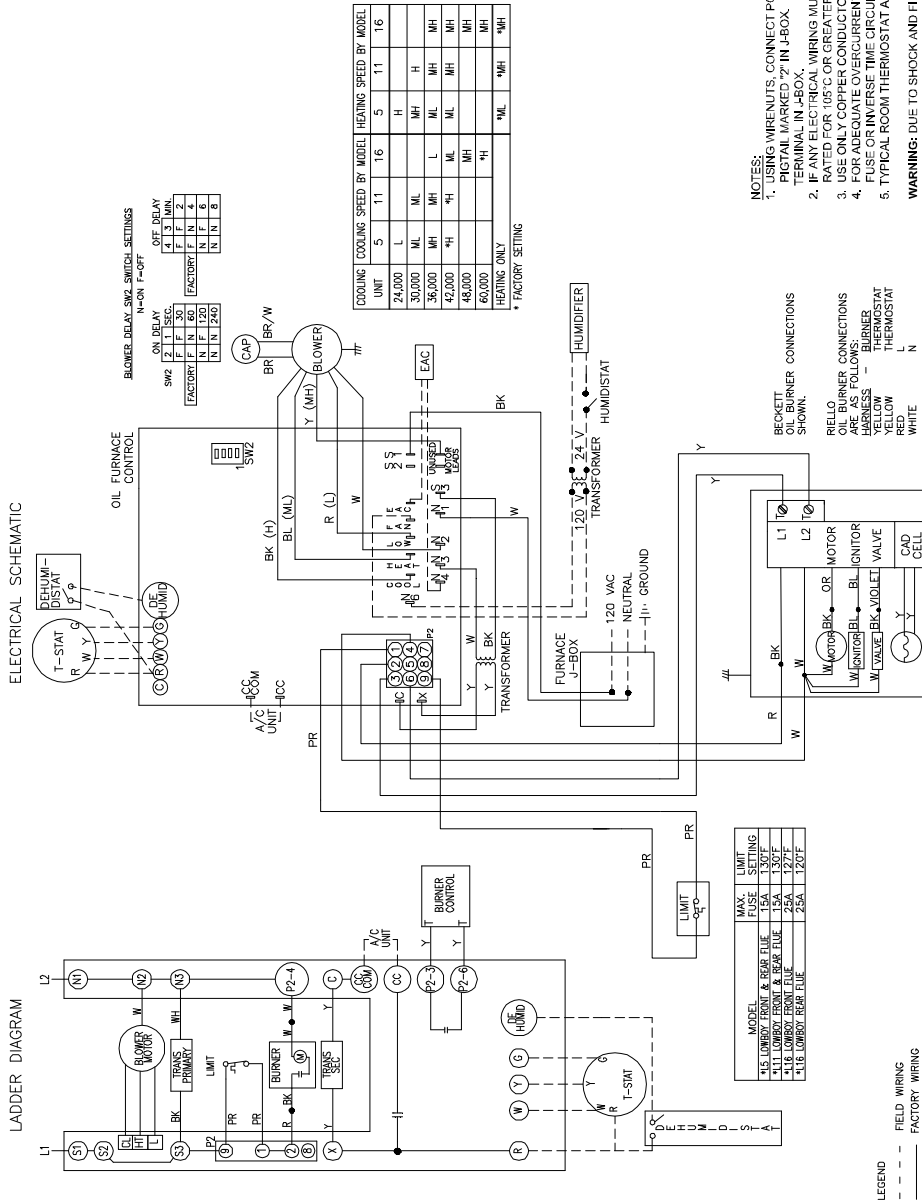

### OPERATING INSTRUCTIONS

For your safety, read this information before operating this furnace.

**WARNING: Failure to follow these instructions may result in a fire or explosion causing property damage, personal injury, or loss of life.**

**WHAT TO DO IN THE EVENT OF AN OIL LEAK:**

- Do not try to operate this or any other nearby appliances.
- Immediately call a qualified heating contractor for service.
- If you cannot reach a qualified heating contractor, call the fuel oil supplier or the fire department.

DO NOT use this furnace if any component was underwelder. Immediately call a qualified heating contractor to inspect the furnace and replace any part of the furnace control system that was underwelder.

This furnace does not have a pilot light. It is equipped with an ignition system that automatically lights the burner. DO NOT attempt to light the burner by hand.

**TO OPERATE THIS FURNACE:**

- Adjust the room thermostat to the lowest setpoint and set the operating mode, if equipped, to "OFF".
- Turn off all electric power to the furnace at the disconnecting switch.
- Rotate the manual oil shutoff valve to the open or on position.
- This furnace is equipped with an electronic ignition system that automatically lights the burner. DO NOT try to light the burner by hand.
- Turn on the electric power to the furnace at the disconnecting switch.
- Adjust the room thermostat to the desired setpoint and set the operating mode, if equipped, to "HEAT".
- If the furnace will not operate, call a qualified heating contractor for service.

**TO INTERRUPT (STOP) OPERATION OF THIS FURNACE:**

- Adjust the room thermostat to the lowest setpoint and set the operating mode, if equipped, to "OFF".
- If service will be performed, turn off all electrical power to the furnace at the disconnecting switch.
- Turn the manual oil shutoff valve to the closed or off position.

**NOTES:**

- USING WIRENUTS, CONNECT POWER SUPPLY WIRE L1 TO PIGTAIL MARKED "1" AND WIRE L2 TO TERMINAL IN J-BOX. CONNECT AN EARTH GROUNDING WIRE TO GROUND WIRE TERMINAL IN J-BOX.
- IF ANY ELECTRICAL WIRING MUST BE REPLACED, NEW WIRING MUST HAVE AN INSULATION TYPE RATED FOR 105°C OR GREATER.
- USE ONLY COPPER CONDUCTORS FOR ALL FIELD AND REPLACEMENT WIRING.
- FOR ADEQUATE OVERCURRENT PROTECTION, MAXIMUM ACCEPTABLE SIZE TIME DELAY TYPE FUSE OR INVERSE TIME CIRCUIT BREAKER REFER TO NAME PLATE.
- TYPICAL ROOM THERMOSTAT ANTICIPATOR SETTING IS 0.2 A.

**WARNING:** DUE TO SHOCK AND FIRE HAZARD, CLASS 2 HEATING AND COOLING CIRCUITS MUST REMAIN SEPARATED.

# ELECTRICAL DIAGRAMS & OPERATING INSTRUCTIONS FOR HORIZONTAL OIL FURNACE

## OPERATING INSTRUCTIONS

LADDER DIAGRAM

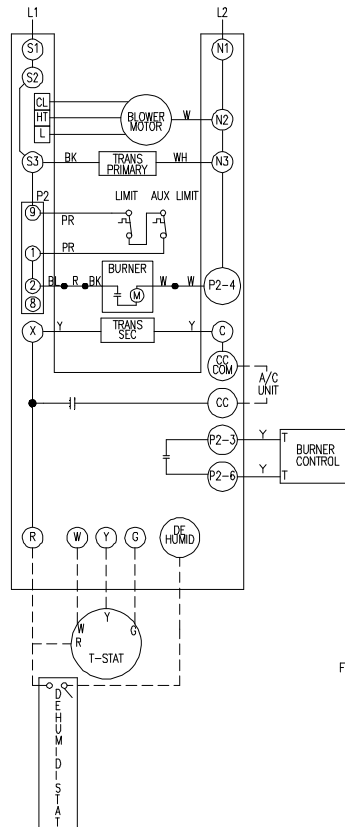

ELECTRICAL SCHEMATIC

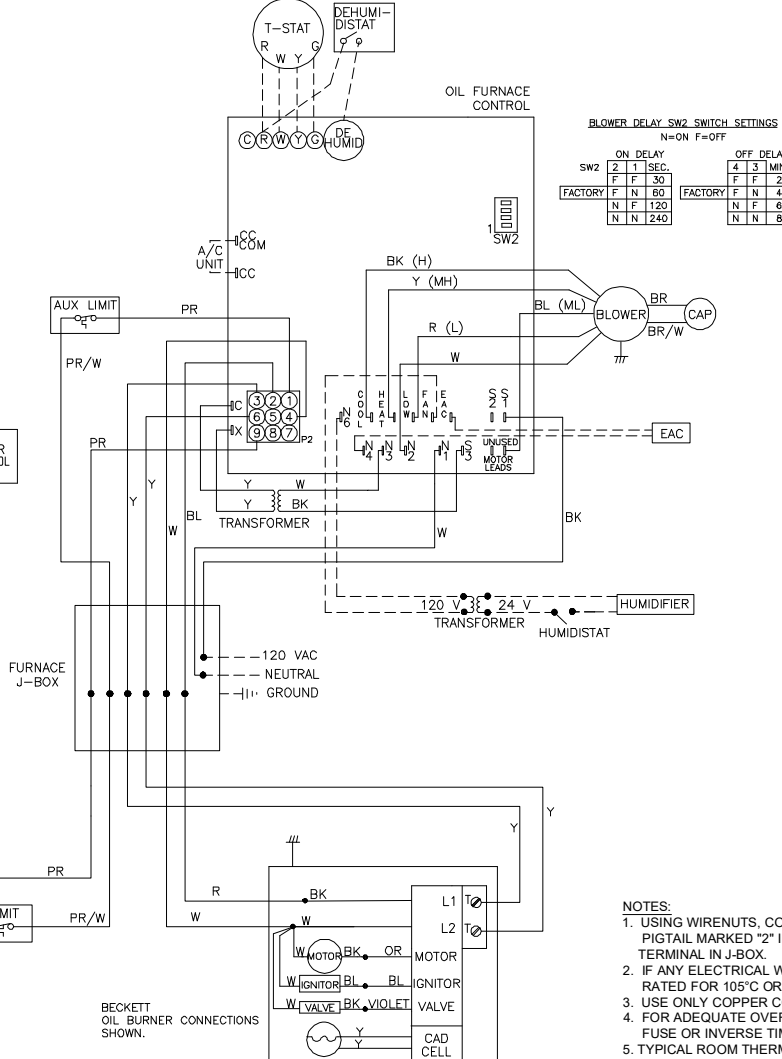

**BLOWER DELAY SW2 SWITCH SETTINGS**  
N=ON F=OFF

SW2	ON DELAY		OFF DELAY	
	2	1	4	3
FACTORY	F	F	F	F
	N	F	N	F
	N	N	N	N

For your safety, read this information before operating this furnace.

**WARNING: Failure to follow these instructions may result in a fire or explosion causing property damage, personal injury, or loss of life.**

**WHAT TO DO IN THE EVENT OF AN OIL LEAK:**

- Do not try to operate this or any other nearby appliance.
- Immediately call a qualified heating contractor for service.
- If you cannot reach a qualified heating contractor, call the fuel oil supplier or the fire department.

DO NOT use this furnace if any component was underwater. Immediately call a qualified heating contractor to inspect the furnace and replace any part of the furnace control system that was underwater.

This furnace does not have a pilot light. It is equipped with an ignition system that automatically lights the burner. DO NOT attempt to light the burner by hand.

**TO OPERATE THIS FURNACE:**

1. Adjust the room thermostat to the lowest setpoint and set the operating mode, if equipped, to "OFF".
2. Turn off all electric power to the furnace at the disconnecting switch.
3. Rotate the manual oil shutoff valve to the open or on position.
4. This furnace is equipped with an electronic ignition system that automatically lights the burner. DO NOT try to light the burner by hand.
5. Turn on the electric power to the furnace at the disconnecting switch.
6. Adjust the room thermostat to the desired setpoint and set the operating mode, if equipped, to "HEAT".
7. If the furnace will not operate, call a qualified heating contractor for service.

**TO INTERRUPT (STOP) OPERATION OF THIS FURNACE:**

1. Adjust the room thermostat to the lowest setpoint and set the operating mode, if equipped, to "OFF".
2. If service will be performed, turn off all electrical power to the furnace at the disconnecting switch.
3. Turn the manual oil shutoff valve to the closed or off position.

**NOTES:**

1. USING WIRENUTS, CONNECT POWER SUPPLY WIRE L1 TO PIGTAIL MARKED "1" AND WIRE L2 TO PIGTAIL MARKED "2" IN J-BOX. CONNECT AN EARTH GROUNDING WIRE TO GROUND WIRE TERMINAL IN J-BOX.
2. IF ANY ELECTRICAL WIRING MUST BE REPLACED, NEW WIRING MUST HAVE AN INSULATION TYPE RATED FOR 105°C OR GREATER.
3. USE ONLY COPPER CONDUCTORS FOR ALL FIELD AND REPLACEMENT WIRING.
4. FOR ADEQUATE OVERCURRENT PROTECTION, MAXIMUM ACCEPTABLE SIZE TIME DELAY TYPE FUSE OR INVERSE TIME CIRCUIT BREAKER REFER TO NAME PLATE.
5. TYPICAL ROOM THERMOSTAT ANTICIPATOR SETTING IS 0.2 A.

**WARNING: DUE TO SHOCK AND FIRE HAZARD, CLASS 2 HEATING AND COOLING CIRCUITS MUST REMAIN SEPARATED.**

**LEGEND**

- - - - - FIELD WIRING
- FACTORY WIRING

MODEL	MAX. FUSE	LIMIT SETTING
**11 HORIZ FRONT FLUE, LEFT DISCHARGE	15A	160°F
**11 HORIZ FRONT FLUE, RIGHT DISCHARGE	15A	120°F
**11 HORIZ REAR FLUE	15A	160°F
**16 HORIZ FRONT FLUE, LEFT DISCHARGE	25A	150°F
**16 HORIZ FRONT FLUE, RIGHT DISCHARGE	25A	120°F
**16 HORIZ REAR FLUE	25A	160°F

COOLING UNIT	COOLING SPEED BY MODEL		HEATING SPEED BY MODEL	
	11	16	11	16
24,000	L		H	
30,000	ML		H	
36,000	MH		H	
42,000	*H		MH	
48,000				
60,000		*H		*H
HEATING ONLY			*MH	*MH

\* FACTORY SETTING

BECKETT OIL BURNER CONNECTIONS SHOWN.

RIELLO OIL BURNER CONNECTIONS ARE AS FOLLOWS:  
HARNES — BURNER  
YELLOW — THERMOSTAT  
BLUE — THERMOSTAT  
WHITE — L  
          — N

All installations and services must be performed by qualified service personnel.

OL11-105\*DBE, OL16-125\*DBE

OPERATING INSTRUCTIONS

For your safety, read this information before operating this furnace.

**WARNING: Failure to follow these instructions may result in a fire or explosion causing property damage, personal injury, or loss of life.**

WHAT TO DO IN THE EVENT OF AN OIL LEAK:

- Do not try to operate this or any other nearby appliance.
- Immediately call a qualified heating contractor for service.
- If you cannot reach a qualified heating contractor, call the fuel oil supplier or the fire department.

DO NOT use this furnace if any component was underwater. Immediately call a qualified heating contractor to inspect the furnace and replace any part of the furnace control system that was underwater.

This furnace does not have a pilot light. It is equipped with an ignition system that automatically lights the burner. DO NOT attempt to light the burner by hand.

TO OPERATE THIS FURNACE:

- Adjust the room thermostat to the lowest setpoint and set the operating mode, if equipped, to "OFF".
- Turn off all electric power to the furnace at the disconnecting switch.
- Rotate the manual oil shutoff valve to the open or on position.
- This furnace is equipped with an electronic ignition system that automatically lights the burner. DO NOT try to light the burner by hand.
- Turn on the electric power to the furnace at the disconnecting switch.
- Adjust the room thermostat to the desired setpoint and set the operating mode, if equipped, to "HEAT".
- If the furnace will not operate, call a qualified heating contractor for service.

TO INTERRUPT (STOP) OPERATION OF THIS FURNACE:

- Adjust the room thermostat to the lowest setpoint and set the operating mode, if equipped, to "OFF".
- If service will be performed, turn off all electrical power to the furnace at the disconnecting switch.
- Turn the manual oil shutoff valve to the closed or off position.

- NOTES:**
- USING WIRES: CONNECT POWER SUPPLY WIRE L1 TO DIGITAL MARKED "1" AND WIRE L2 TO DIGITAL MARKED "2" IN J-BOX. CONNECT AN EARTH-GROUNDING WIRE TO GROUND WIRE TERMINAL IN J-BOX. WIRING MUST BE REPLACED. NEW WIRING MUST HAVE AN INSULATION TYPE RATED FOR 105°C OR GREATER.
  - USE ONLY COPPER CONDUCTORS FOR ALL FIELD AND REPLACEMENT WIRING.
  - FOR ADEQUATE OVERCURRENT PROTECTION, MAXIMUM ACCEPTABLE SEE TIME DELAY TYPE FUSE OR INVERSE TIME CIRCUIT BREAKER REFER TO NAME PLATE.
  - TYPICAL ROOM THERMOSTAT ANTICIPATOR SETTING IS 0.2 A.

**WARNING:** DUE TO SHOCK AND FIRE HAZARD, CLASS 2 HEATING AND COOLING CIRCUITS MUST REMAIN SEPARATED.

ELECTRICAL DIAGRAMS & OPERATING INSTRUCTIONS FOR LOWBOY OIL FURNACE

P/N WD-632  
ECN 5325AMA

