



ECM OPERATION MANUAL

FOR USE WITH MODELS:

OH5-85DE	OL5-85FDE	OL5-85RDE
OH11-105DE	OL11-105FDE	OL11-105RDE
OH2-56DE	OL2-56FDE	OL2-56RDE
OC5-85DE	OC2-56DE	OH5-85DXE

⚠WARNING: IF YOU DO NOT FOLLOW THE SAFETY PRECAUTIONS BELOW AND IN THIS MANUAL, A FIRE OR EXPLOSION MAY RESULT CAUSING PROPERTY DAMAGE, PERSONAL INJURY, OR LOSS OF LIFE.

DO NOT STORE OR USE GASOLINE OR OTHER FLAMMABLE VAPORS AND LIQUIDS IN THE VICINITY OF THIS OR ANY OTHER APPLIANCE.

INSTALLATION AND SERVICE MUST BE PERFORMED BY A QUALIFIED INSTALLER, SERVICE AGENCY OR THE GAS SUPPLIER. (REFERRED TO IN THESE INSTRUCTIONS AS A QUALIFIED HEATING CONTRACTOR).

PLEASE READ THESE INSTRUCTIONS PRIOR TO INSTALLATION, INITIAL FIRING, AND BEFORE PERFORMING ANY SERVICE OR MAINTENANCE. THESE INSTRUCTIONS MUST BE LEFT WITH THE HOMEOWNER AND SHOULD BE RETAINED FOR FUTURE REFERENCE BY QUALIFIED SERVICE PERSONNEL.

THERMO PRODUCTS, LLC.
BOX 217
NORTH JUDSON, IN 46366
PHONE: (574) 896-2133

MADE IN USA

All installations and services must be performed by qualified service personnel.

INDEX

<u>SECTION</u>	<u>BEGINNING PAGE</u>
I. FURNACE SPECIFICATIONS (SHIPPED SETTINGS)	1
II. BLOWER CONTROL INFORMATION	4
A. TERMINAL DEFINITIONS & FIELD WIRING	4
B. WIRING & SWITCHES	5
C. INPUTS	9
D. OUTPUTS	9
E. OPERATING MODES	10
F. CFM TABLES	12
G. ECM SPECIFIC REPLACEMENT PARTS	13
III. ECM TROUBLESHOOTING	13
A. DIAGNOSTIC FEATURES	13
B. GENERAL GUIDELINES TO TROUBLESHOOTING GE ECM	14
C. TROUBLESHOOTING CHARTS	17

All installations and services must be performed by qualified service personnel.

I. FURNACE SPECIFICATIONS (SHIPPED SETTINGS)

OL SERIES

MODEL NO.	OL2-56	OL5-85	OL11-105
HEAT INPUT RATE IN BTU/HR	70,000	106,250	126,000
HEATING CAPACITY IN BTU/HR	56,000	85,000	101,000
HEIGHT OF CASING	34-3/4"	43-1/4"	46-1/2"
WIDTH OF CASING	19"	25"	25"
DEPTH OF CASING	48"	50-1/4"	54-1/2"
WARM AIR OUTLET	17 x 17	20 x 20	20 x 20
RETURN AIR INLET	17 x 17	20 x 14	20 x 16
DIA. OF FLUE OUTLET	5"	6"	6"
FLOOR-CENTER OF FLUE	29-1/4"	36"	38-1/2"
FLOWRATE from .2" & .5" w.c. EXTERNAL STATIC PRESSURE	COOLING	COOLING	COOLING
@2 TON SWITCH SELECTION (CFM)	800	800	800
@2-1/2 TON SWITCH SELECTION (CFM)	1000	1000	1000
@3 SWITCH SELECTION (CFM)	1200	1200	1200
@3-1/2 TON SWITCH SELECTION (CFM)	1400	1400	1400
	HEATING	HEATING	HEATING
@70deg SWITCH SELECTION (CFM)	737	1134	1335
APPROX TEMPERATURE RISE (°F)	70	70	70
BLOWER MOTOR HP	1/2	1/2	1/2
NOZZLE SIZE	.55	.75	.90
NOZZLE SPRAY ANGLE PATTERN	80° Hollow	80° Hollow	80° Hollow
LARGEST RECOMMENDED AIR CONDITIONER	3.5 Ton	3.5 Ton	3.5 Ton
SIZE OF FILTERS	16" x 20"	20" x 20"	20" x 25"

NOTES:

1. Heating capacity based on annual fuel utilization efficiency rated by manufacturer.
2. On all outlet and inlet dimensions, the first dimension is width.
3. To permit largest recommended air conditioning (at .5 static pressure), selection of the highest motor speed is required.
4. Electrical characteristics at 115 volts, 60 Hz., 1 phase (less than 15 amps, for all models).
5. All specifications are subject to change without notice.

All installations and services must be performed by qualified service personnel.

OH SERIES

MODEL NO.	OH2	OH5-85	OH11-105	OH5-85DXE
HEAT INPUT RATE IN BTU/HR	70,000	106,250	126,000	85,000 106,250
HEATING CAPACITY IN BTU/HR	56,000	85,000	101,000	74,000 85,000
HEIGHT OF CASING	52"	56"	59-1/2"	56"
WIDTH OF CASING	19"	24"	24"	24"
DEPTH OF CASING	27"	33"	34"	33"
WARM AIR OUTLET	17 x 17	22 x 20	22 x 20	22 x 20
RETURN AIR INLET	18 x 14	23 x 14	25 x 16	25 x 16
DIA. OF FLUE OUTLET	5"	6"	6"	6"
FLOOR-CENTER OF FLUE	TOP	TOP	TOP	TOP
FLOWRATE from .2" & .5" w.c. EXTERNAL STATIC PRESSURE	COOLING	COOLING	COOLING	COOLING
@2 TON SWITCH SELECTION (CFM)	800	800	800	726
@2-1/2 TON SWITCH SELECTION (CFM)	1000	1000	1000	924
@3 SWITCH SELECTION (CFM)	1200	1200	1200	1276
@3-1/2 TON SWITCH SELECTION (CFM)	1400	1400	1400	1474
4 TON				1600
	HEATING	HEATING	HEATING	HEATING
@70deg SWITCH SELECTION (CFM)	737	1134	1335	905 1121
APPROX TEMPERATURE RISE (°F)	70	70	70	72 70
BLOWER MOTOR HP	1/2	1/2	1/2	3/4
NOZZLE SIZE	.55	.75	.90	.70
NOZZLE SPRAY ANGLE PATTERN	80° Hollow	80° Hollow	80° Hollow	45° W
LARGEST RECOMMENDED AIR CONDITIONER	3.5 Ton	3.5 Ton	3.5 Ton	4 Ton
SIZE OF FILTERS	20" x 16"	25" x 16"	25" x 16"	20" x 25"

NOTES:

1. Heating capacity based on annual fuel utilization efficiency rated by manufacturer.
2. On all outlet and inlet dimensions, the first dimension is width.
3. To permit largest recommended air conditioning (at .5 static pressure), selection of the highest motor speed is required.
6. Electrical characteristics at 115 volts, 60 Hz., 1 phase (less than 15 amps, for all models).

All installations and services must be performed by qualified service personnel.

OC SERIES

MODEL NO.	OC2-56	OC5-85
HEAT INPUT RATE IN BTU/HR	70,000	106,250
HEATING CAPACITY IN BTU/HR	56,000	85,000
HEIGHT OF CASING	57-1/2"	56"
WIDTH OF CASING	19"	24"
DEPTH OF CASING	27"	33"
WARM AIR OUTLET	17 x 17	16 x 20
RETURN AIR INLET	17 x 17	22 x 20
DIA. OF FLUE OUTLET	5"	6"
FLOOR-CENTER OF FLUE	TOP	TOP
FLOWRATE from .2" & .5" w.c. EXTERNAL STATIC PRESSURE	COOLING	COOLING
@2 TON SWITCH SELECTION (CFM)	800	800
@2-1/2 TON SWITCH SELECTION (CFM)	1000	1000
@3 SWITCH SELECTION (CFM)	1200	1200
@3-1/2 TON SWITCH SELECTION (CFM)	1400	1400
	HEATING	HEATING
@70deg SWITCH SELECTION (CFM)	737	1134
APPROX TEMPERATURE RISE (°F)	70	70
BLOWER MOTOR HP	1/2	1/2
NOZZLE SIZE	.55	.75
NOZZLE SPRAY ANGLE PATTERN	80° Hollow	80° Hollow
LARGEST RECOMMENDED AIR CONDITIONER	3.5 Ton	3.5 Ton
SIZE OF FILTERS	17" x 10"	20" x 12"

NOTES:

1. Heating capacity based on annual fuel utilization efficiency rated by manufacturer.
2. On all outlet and inlet dimensions, the first dimension is width.
3. To permit largest recommended air conditioning (at .5 static pressure), selection of the highest motor speed is required.
7. Electrical characteristics at 115 volts, 60 Hz., 1 phase (less than 15 amps, for all models).
8. All specifications are subject to change without notice.

All installations and services must be performed by qualified service personnel.

II. BLOWER CONTROLLER INFORMATION

A. TERMINAL DEFINITIONS & FIELD WIRING

Burner Harness Connector P1

- Pin 1 – Limit switch connection.
- Pin 2 – 120 VAC Line connection.
- Pin 3 – Burner pilot contact.
- Pin 4&5 – 120 VAC Neutral connection.
- Pin 6 – Burner pilot contact.
- Pin 7&8 – From oil primary control.
- Pin 9 – Limit Switch Input (LSI).

Field Wiring to Burner

	Pilot (Tstat)	Neutral	Line
Harness Wires	Yellow Wires	White	Red
Beckett Connections	T-T terminals	White	Black
Riello Connections	T-stat terminals	White	Black

Thermostat/Humidistat connections

- "C" Common/ground
- "W" Thermostat call for heat
- "R" 24 VAC to thermostat
- "G" Thermostat call for fan
- "Y" Thermostat call for cool
- "DEHUM" Humidistat call for dehumidification (TXV systems ONLY)

Thermostat/Humidistat connections for 2-Stage control

- "C" Common/ground
- "W1" T-Stat call for heat (low fire)
- "W2" T-Stat call for heat (high fire)
- "R" 24 vac to T-Stat
- "G" T-Stat call for fan
- "Y" T-Stat call for cool
- "DEHUM" Humidistat call for dehumidification (TXV systems ONLY)

ECM control outputs

- Pin 1 - Speed Common
- Pin 2 - Speed Output
- Pin 3 – Motor CFM
- Pin 4 – Blower Enable
- Pin 5 – COOL Enable
- Pin 6 – "R" Output

Male quick connect terminals.

- "S1-3" 120 VAC Hot
- "N1-7" 120 VAC Neutral
- "EAC" Electronic Air Cleaner (120 VAC) connection.
- "HUM" Humidifier connection (120 VAC).
- "FAN" Fan On Signal
- "X" 24VAC from transformer.
- "C" 24VAC common from transformer.
- "CC" Compressor Contactor
- "CC_COM" Compressor Contactor Common

All installations and services must be performed by qualified service personnel.

B. WIRING & SWITCHES

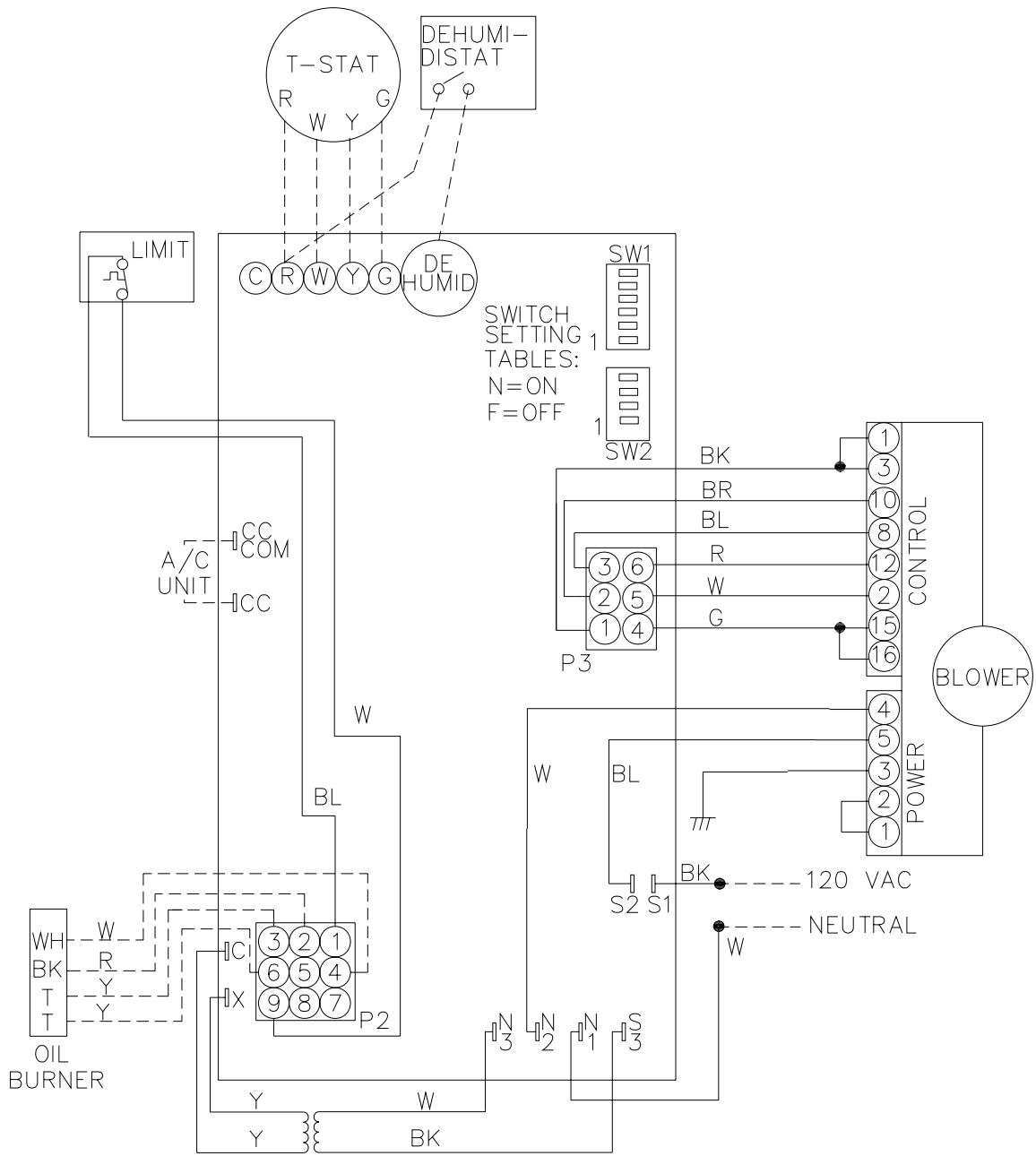

HIGHBOY/LOWBOY

Figure 1: BLOWER WIRING

All installations and services must be performed by qualified service personnel.

⚠WARNING: *TURN OFF THE ELECTRICAL POWER to the furnace before attempting to disconnect blower wiring.*

COUNTERFLOW

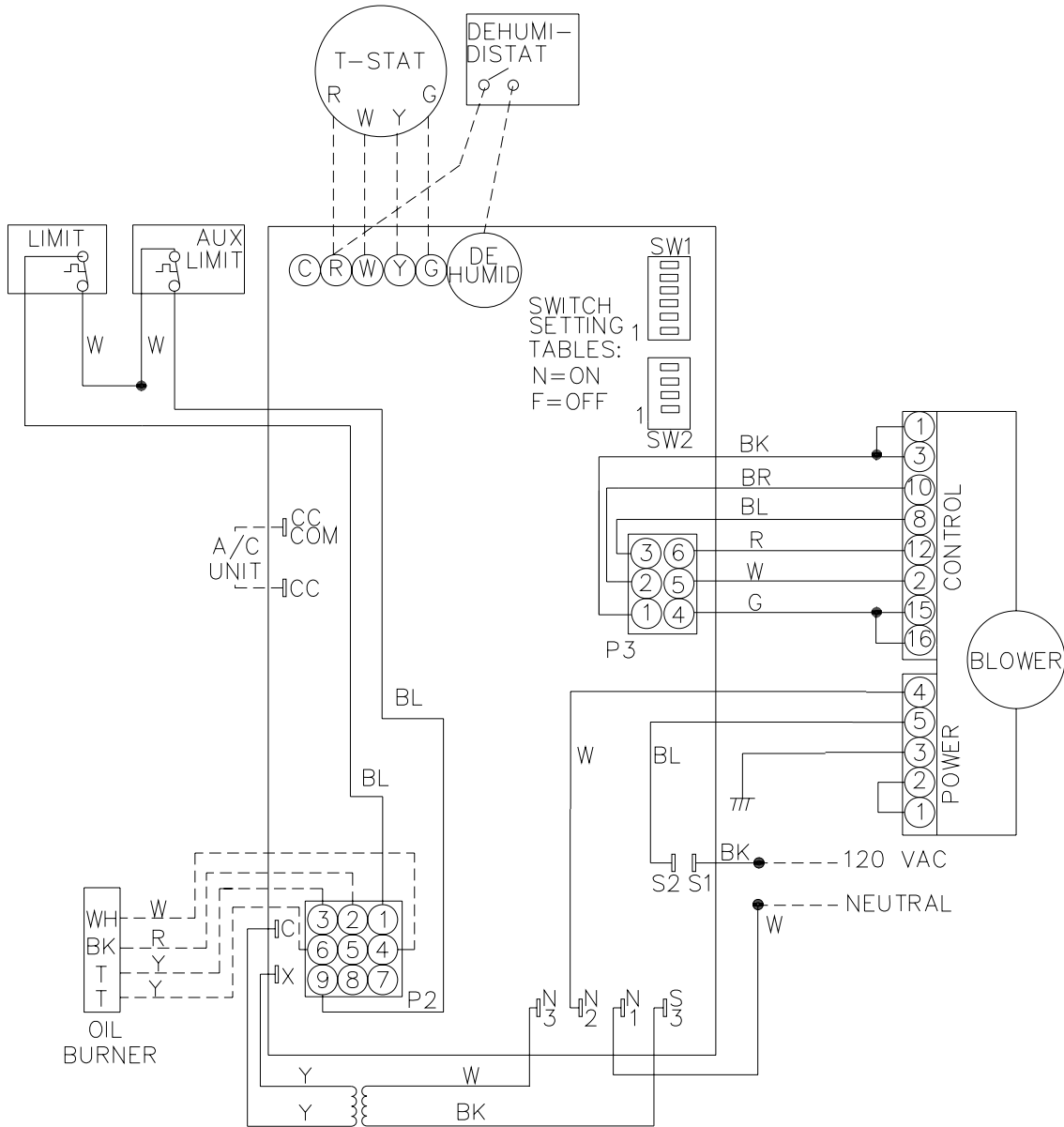

Figure 2: BLOWER WIRING

All installations and services must be performed by qualified service personnel.

⚠WARNING: *TURN OFF THE ELECTRICAL POWER to the furnace before attempting to disconnect blower wiring.*

**OH5-85 DXE
2-STAGE**

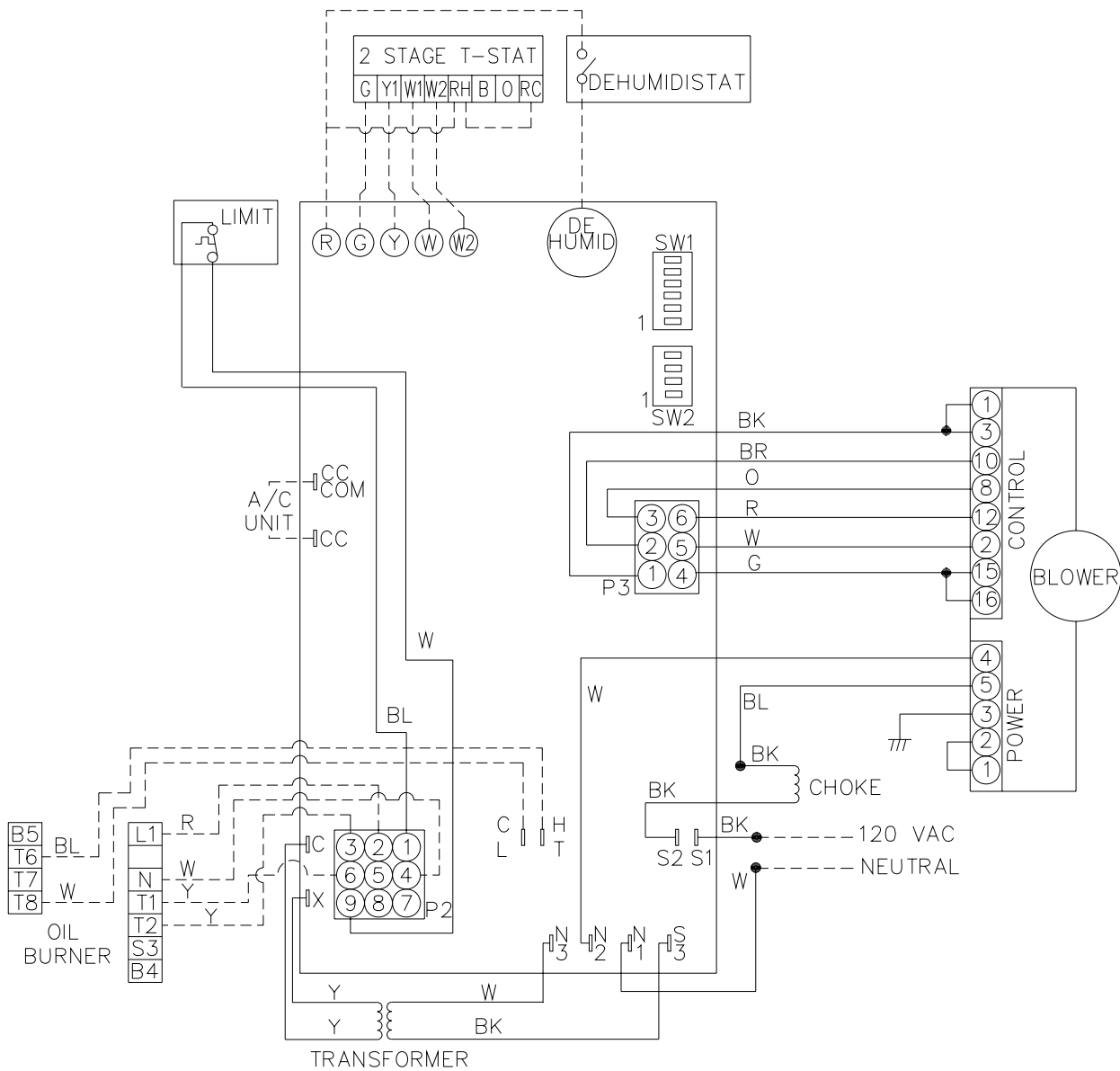

Figure 3: BLOWER WIRING

⚠WARNING: *TURN OFF THE ELECTRICAL POWER to the furnace before attempting to disconnect blower wiring.*

All installations and services must be performed by qualified service personnel.

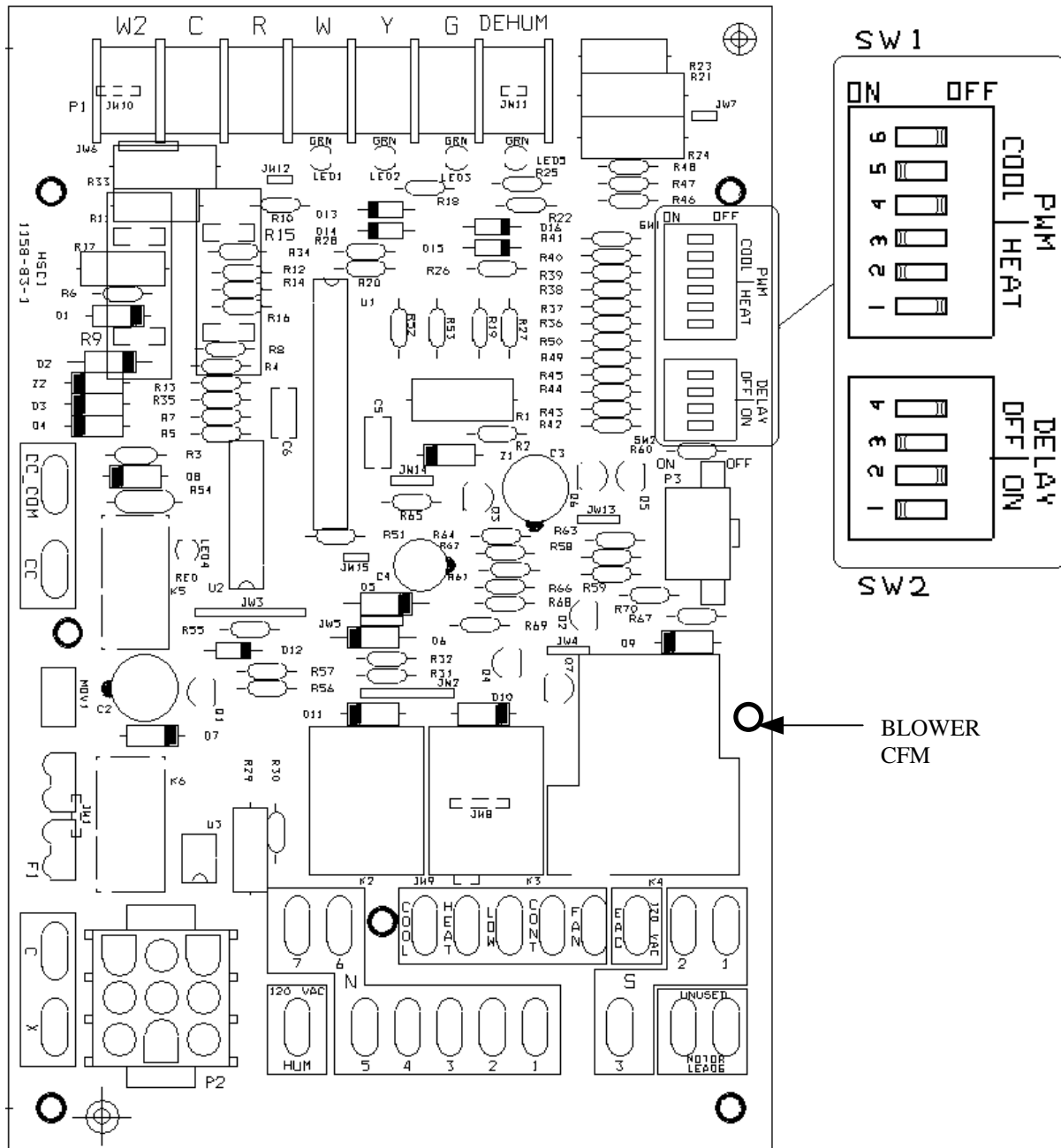

Figure 2: BOARD LAYOUT WITH SWITCHES

All installations and services must be performed by qualified service personnel.

C. Inputs

Power supplies

Line voltage is applied between the "S1" and "N1" quick connect terminals.
24 VAC Class II Transformer secondary voltage supplied to X and C

Limit Switch

The 120VAC optically isolated limit switch input is connected on pin P2-1 & 9. Refer to the Heat Mode section for the control operation.

Thermostat call for heat "W"

24 VAC thermostat input. A call for heat is recognized when the thermostat connects "W" to "R". This input has an indicator LED that will light when the control receives a call for heat. Refer to the Heat Mode section for the control operation.

Thermostat call for heat "W2"

24 VAC thermostat input. A call for heat is recognized when the thermostat connects "W2" to "R". This input has an indicator LED that will light when the control receives a call for heat. Refer to the Heat Mode section for the control operation.

Thermostat call for cool, "Y"

24 VAC thermostat input. A call for cooling is recognized when the thermostat connects "Y" to "R". This input has an indicator LED that will light when the control receives a call for cooling. . Refer to the Cool Mode section for the control operation.

Thermostat call for dehumidification "DEHUM"

24 VAC thermostat input. A call for dehumidification is recognized when the humidistat connects "DEHUM" to "R". This input has an indicator that will light when the control receives a call for dehumidification. Refer to the Cool Mode section for the control operation.

Thermostat call for fan "G"

24 VAC thermostat input. A call for fan is recognized when the thermostat connects "G" to "R". This input has an indicator LED in that will light when the control receives a call for fan. Refer to the Fan Mode section for the control operation.

D. Outputs

ECM Control

The control controls a multiple speed ECM motor through the 6-pin P3 connector. This connector provides connection for ECM Speed common (Pin 1), Speed output (Pin 2), Blower Enable (Pin 4), Cool Enable (Pin 5) and "R" output (Pin 6).

Oil Burner

Control

The control provides dedicated contacts to operate the T-T input of an oil primary control. Rating shall be class 2 - 24 VAC pilot duty @ 24 VAC (< 200mA).

Power

The switched 120VAC power from the LIMIT switch passes through the board between Pins 1&2 of connector P1.

All installations and services must be performed by qualified service personnel.

Compressor contactor

The control provides switched 24VAC to operate a compressor contactor. Rating shall be class 2 - 24 VAC pilot duty @ 24 VAC (< 200mA).

EAC (electronic air cleaner)

The control provides a 120VAC output for an electronic air cleaner. This output is energized whenever the fan motor is energized (either low, heat or cool speed). Connection is made via male quick connect terminal labeled "EAC".

Humidifier

The control provides a 120 VAC output for a humidifier. Connections are made to a male quick connect terminal labeled "HUM". The control does not switch this output, it provides a pass-through connection from P1-7 from the switched primary voltage of the Burner Module.

Status LED

A red LED is provided to indicate any thermostat input has been recognized by the microprocessor on the control. See Diagnostic Features for a function description of operation.

Thermostat Input LEDs

Four green LEDs are placed beneath their respective thermostat connections (W, Y, G and DEHUM) and operate whenever a call is present. See Diagnostic Features for a function description of operation.

Motor CFM LED

This green LED will flash once for every 100CFM the blower is producing.

E. Operating Modes

Standby Mode

All outputs are off and the control is waiting for a thermostat demand. The thermostat inputs, and limit switch are continuously monitored. The control initiates action when a thermostat call is received or limit switch opens.

Fan Mode

A call for fan ("G") is received from the thermostat. If no other mode is calling for blower operation, the control will choose a "Low" speed value from the position of DIP switch SW1 positions 4 through 6, as shown in the CFM Tables and operate the fan at that speed. The fan mode will be operated as long as the "G" input is calling and neither the Heat mode nor the Cool mode is calling for blower operation. When the Heat and Cool modes call for blower operation, their respective outputs will take over after their respective turn-on time delays have expired. The speed Output is present until the fan call is satisfied.

Cooling Mode

A call for cool ("Y") is received from the thermostat. If the heat mode is not active or the anti-short cycle delay is not in effect, the control will energize the "CC" terminal. After a 10 second delay blower ramps up to the "COOL" speed determined by the position of DIP switch SW1 (positions 4 through 6) determine a speed as shown in CFM Tables.

When the call for cool is satisfied, the "CC" terminal is de-energized and the cooling off delay of 45 seconds is started. Forty-five seconds later the blower speed ramps toward zero and the control reverts to Standby Mode.

Dehumidification Operation

If a call for dehumidification is received while the Cool Mode is active, blower speeds will be reduced. The speed value will be selected from the DEHUM column of the CFM Tables. This input may only be used on systems using a thermostatic expansion valve (TXV) on the evaporator.

All installations and services must be performed by qualified service personnel.

Anti-Short Cycle Operation

To prevent compressor short cycling, a call for cooling will be ignored for four minutes after the termination of any cooling call. The anti-short cycle delay is also in effect at power-up.

Heat Mode

When a call for heat ("W") is received from the thermostat, if the "Cool" mode is not already active, the "T-T" terminal is energized and the blower on delay is started. The on-off pattern of DIP switch SW2 (positions 1 and 2) select one of four blowers on delay values (see Table 1). When the delay time has elapsed, a speed value is read from DIP switch SW1 positions 1 through 3 (see the CFM Tables) and the blower is ramped up to that speed. The 2-Stage control will be operated by t-stat through W1 and W2. For 2-stage control with a single stage t-stat, call for heat will go through W2. When W2 is energized, low fire is activated for 15 minutes. If a call for heat still exists, high fire will be activated and will continue until the demand for heat has been satisfied.

Counterflow units, in addition, will run at a low blower speed shortly after the burner is brought on. They will continue at that speed until the delay time has elapsed.

The control remains in steady heat mode until the thermostat is satisfied. When the call for heat signal is removed, the "T-T" terminal is de-energized and the blower off delay is started. The on-off pattern of DIP switch SW2 (positions 3 and 4) select one of four blower off delay values (see Table 1). When the delay time has elapsed, the blower is ramped toward zero.

Table 1: ON and OFF Blower Delay Time Switch Settings

DIP SWITCH 2 SECTION STATE				BLOWER DELAY TIMES		
2	1	4	3	ON - SEC	OFF - MIN	
OFF	OFF			30		
OFF	ON			60		
ON	OFF			120	Factory Set	
ON	ON			240		
		OFF	OFF		2	
		OFF	ON		4	
		ON	OFF		6	Factory Set
		ON	ON		8	

Motor Blower Speed

Three blower speed outputs are provided. A "G" call for fan will provide the Low speed only. A "W" heat call will provide the Heat speed only. A "Y" cooling call will provide the Cool speed only.

In the case of thermostat calls for "Y" and "W" together, blower speed selection will be determined by the input that was first initiated. In the case where the control is in a cooling mode with both "Y" and "W" inputs energized and then the "Y" input is removed, the cooling blower off time will be executed prior to the control switching into a heating mode. In the case where the control is in a heating mode with both "Y" and "W" inputs energized and then the "W" input is removed, the heating blower off time will be executed prior to the control switching into a cooling mode. In the case where a call for fan "G" already exists and either a "W" or a "Y" call is initiated, the blower speed will switch to the respective "W" or a "Y" speed following the blower on delay for that call.

Six dip switches select Speed values for heat, cool, fan and dehumidification blower speeds (see the CFM Tables).

Blower On and Off Delays

Four Heat blower on and four blower off delays are selected by two dip switches for each function. Refer to Table 1 for specific delay values.

All installations and services must be performed by qualified service personnel.

Speed Selection values

Three dip switches select 8 cooling speeds. Dependant fan, and dehumidification speeds are selected by the same switches, their tabular values are enacted when their function is called.

Three additional dip switches select 8 heating speeds which are enacted when heat is called. This allows independent selection of heating and cooling capacity parameters. See the CFM Tables for speeds.

F. CFM TABLES

The following tables contain blower speed settings and their respective air flowrates for the ECM blower motor. To change air flowrates from that of the shipped settings, use the respective SW1 dipswitch on the furnace's integrated control board (see Figure 2).

COOLING SPEEDS

ALL UNITS

SW 1 switch settings	Tons	CFM		
		COOL	LOW	DEHUM
6-OFF 5-OFF 4-OFF	2	800	400	560
6-OFF 5-OFF 4-ON	2.5	1000	500	700
6-OFF 5-ON 4-OFF	3	1200	600	840
6-OFF 5-ON 4-ON	3.5	1400	700	980
ADDITIONAL OH11, OL11 SETTINGS ONLY				
6-ON	4	1500	800	1120
5-OFF				
4-OFF				

Factory shipped
settings

HEATING SPEEDS & TEMPERATURE RISE

SW1 switch settings	OH2, OL2, OC2		OH5, OL5, OC5		OH11, OL11	
	°F Rise	CFM	°F Rise	CFM	°F Rise	CFM
3-OFF 2-OFF 1-OFF	82	636				
3-OFF 2-OFF 1-ON	75	696				
3-OFF 2-ON 1-OFF	69	756				
3-OFF 2-ON 1-ON	63	828	82	966		
3-ON 2-OFF 1-OFF	58	900	75	1050	84	1125
3-ON 2-OFF 1-ON			69	1148	77	1230
3-ON 2-ON 1-OFF			63	1260	70	1350
3-ON 2-ON 1-ON			56	1400	63	1500

Operating Conditions
Are NOT Approved

All installations and services must be performed by qualified service personnel.

OH5 2-STAGE

SW1 SETTING	TONS	CFM	
		COOL	LOW
6 OFF 5 OFF 4 ON	2	726	352
6 OFF 5 OFF 4 ON	2.5	924	462
6 OFF 5 ON 4 ON	3	1276	638
6 ON 5 OFF 4 OFF	3.5	1474	726
6 ON 5 OFF 4 ON	4	1600	814

OH5 2-STAGE

SW1 SETTING	LOW FIRE		HIGH FIRE	
	CFM	RISE	CFM	RISE
3 OFF 2 ON 1 OFF	800	81	1008	78
3 OFF 2 ON 1 ON	905	72	1121	70
3 ON 2 OFF 1 OFF	960	68	1200	66

 Factory shipped settings

G. ECM SPECIFIC REPLACEMENT PARTS

Part Name	OH5/OH2	OH11	OL5/OL2	OL11	OC5/OC2	OH5 2-STAGE
ECM Motor	AOPS7443/ AOPS7449	AOPS7444	AOPS7445/ AOPS7450	AOPS7446	AOPS7448/ AOPS7447	AOPS7454
Control Board	350915	350915	350915	350915	350915	350184
Motor Power Harness	350917	350917	350918	350918	350917	350917
Motor Control Harness	350920	350920	350921	350921	350920	350183
Burner Harness	350916	350916	350916	350916	350928	350182
Transformer	350464	350464	350464	350464	350464	350464

III. ECM TROUBLE SHOOTING

A. DIAGNOSTIC FEATURES

The control board is equipped with 4 green Input Status LEDs and 1 red Board Status LED. These are intended to provide a quick view into furnace performance without requiring a voltmeter.

The green Input Status LEDs are driven by the “Y”, “W”, “G”, and “DEHUM” inputs and are located directly below those inputs. They will light to indicate the presence of these signals.

The red Board Status LED has two functions:

It will light when the board recognizes a valid input signal and will stay lit until all valid signals are removed. This is intended to show that the board is functioning and able to respond to input signals.

It will flash rapidly while 120VAC is missing from the LIMIT switch. This is intended to give a quick visual indication of the High LIMIT switch.

All installations and services must be performed by qualified service personnel.

B. GENERAL GUIDELINES TO TROUBLESHOOTING GE ECM – DRIVEN SYSTEMS

⚠CAUTION: Disconnect power from unit before removing or replacing connectors, or servicing motor.
Wait at least 5 minutes after disconnecting power before opening motor.

SYMPTOM	CAUSE/PROCEDURE
Motor rocks slightly when starting	<ul style="list-style-type: none"> This is normal start-up for ECM
Motor won't start <ul style="list-style-type: none"> No movement 	<ul style="list-style-type: none"> Check power at motor Check low voltage (24 VAC R to C) at motor Check low voltage connections (G,PWM,W,R,C,) at motor Check for unseated pins in connectors on motor harness Test with a temporary jumper between R – G Check motor for tight shaft Perform motor/control replacement check Run Moisture Check
<ul style="list-style-type: none"> Motor rocks, but won't start 	<ul style="list-style-type: none"> Check for loose or compliant motor mount Make sure blower wheel is tight on shaft Perform motor/control replacement check
Motor oscillates up & down while being tested off of blower	<ul style="list-style-type: none"> It is normal for motor to oscillate with no load on shaft.
Motor starts, but runs erratically <ul style="list-style-type: none"> Varies up and down or intermittent 	<ul style="list-style-type: none"> Check line voltage for variation or “sag” Check low voltage connections (G,PWM,W,R,C,) at motor, unseated pins in motor harness connectors Check “Bk” for erratic CFM command (in variable speed applications) Check-out system controls – T'stat? Perform Moisture Check
<ul style="list-style-type: none"> “Hunts” or “puffs” at high CFM (speed) 	<ul style="list-style-type: none"> Does removing panel or filter reduce “puffing”? <ul style="list-style-type: none"> ➤ Reduce restriction ➤ Reduce max airflow
<ul style="list-style-type: none"> Stays at low CFM despite system call for cool or heat CFM 	<ul style="list-style-type: none"> Check low voltage (T'stat) wires and connections Verify fan is not in delay mode – wait until delay complete “R” missing/not connected at motor Perform motor/control replacement check
<ul style="list-style-type: none"> Stays at high CFM 	<ul style="list-style-type: none"> “R” missing/not connected at motor Is fan in delay mode? – wait until delay time complete Perform motor/control replacement check
<ul style="list-style-type: none"> Blower won't shut off 	<ul style="list-style-type: none"> Current leakage from controls into G,Y or W? Check for Triac switched t'stat or solid state relay
Excessive noise	<ul style="list-style-type: none"> Determine if it's air noise, cabinet, duct or motor noise – interview customer, if necessary
<ul style="list-style-type: none"> Noisy blower or cabinet 	<ul style="list-style-type: none"> Check for loose blower housing, panels, etc. High static creating high blower speed?

All installations and services must be performed by qualified service personnel.

	<ul style="list-style-type: none"> ➤ Check for air whistling thru seams in ducts, cabinets or panels ➤ Check for cabinet/duct deformation
<ul style="list-style-type: none"> • “Hunts” or “puffs” at high CFM (speed) 	<ul style="list-style-type: none"> • Does removing panel or filter reduce “puffing”? <ul style="list-style-type: none"> ➤ Reduce restriction ➤ Reduce max airflow
Evidence of Moisture	
<ul style="list-style-type: none"> • Motor failure or malfunction has occurred and moisture is present 	<ul style="list-style-type: none"> • Replace motor and perform Moisture Check
<ul style="list-style-type: none"> • Evidence of moisture present inside air mover 	<ul style="list-style-type: none"> • Perform Moisture Check

<u>DO</u>	<u>DON'T</u>
<ul style="list-style-type: none"> • Check-out motor, controls, wiring and connections thoroughly before replacing motor 	<ul style="list-style-type: none"> • Automatically assume the motor is bad.
<ul style="list-style-type: none"> • Orient connectors down so water can't get in <ul style="list-style-type: none"> ➤ Install “drip loops” 	<ul style="list-style-type: none"> • Locate connectors above 7 and 4 o'clock positions
<ul style="list-style-type: none"> • Use authorized motor and control model #'s for replacement 	<ul style="list-style-type: none"> • Replace one motor or control model # with another (unless an authorized replacement)
<ul style="list-style-type: none"> • Keep static pressure to a minimum: <ul style="list-style-type: none"> ➤ Recommend high efficiency, low static filters ➤ Recommend keeping filters clean ➤ Design ductwork for min static, max comfort ➤ Look for and recommend ductwork improvement, where necessary, in replacement 	<ul style="list-style-type: none"> • Use high pressure drop filters – some have ½” H₂O drop! • Use restricted returns
<ul style="list-style-type: none"> • Size the equipment wisely 	<ul style="list-style-type: none"> • Oversize system then compensate with low airflow
<ul style="list-style-type: none"> • Check orientation before inserting motor connectors 	<ul style="list-style-type: none"> • Plug in power connector backwards • Force plugs

Moisture Check

- Connectors are orientated “down” (or as recommended by equipment manufacturer)
- Arrange harnesses with “drip loop” under motor
- Is condensate drain plugged?
- Check for low airflow (too much latent capacity)
- Check for undercharged condition
- Check and plug leaks in return ducts, cabinet

Comfort Check

- Check proper airflow settings
- Low static pressure for lowest noise
- Set low continuous-fan CFM
- T'stat in bad location?

All installations and services must be performed by qualified service personnel.

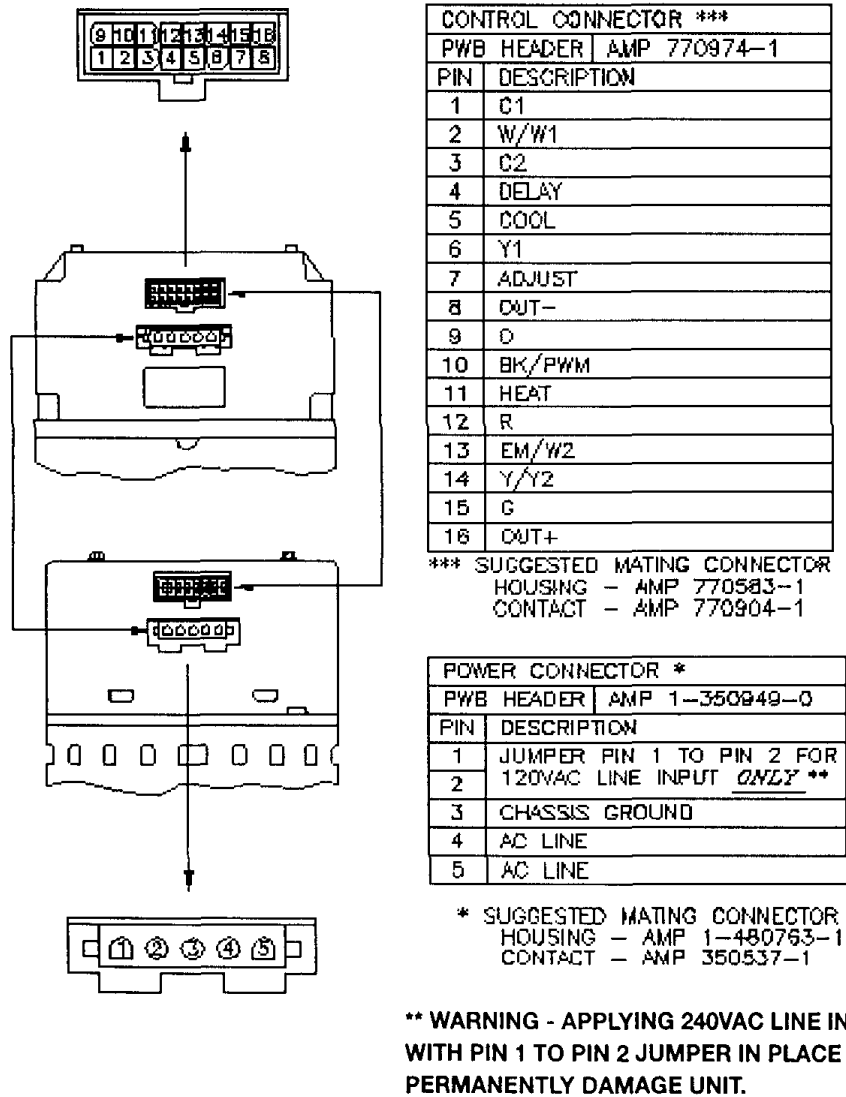

Figure 3: ECM PIN CONNECTORS

Troubleshooting table above and Figure 2 adapted from GE Industrial Systems publication GED-7161C, "Troubleshooting GE ECM - Driven Systems".

All installations and services must be performed by qualified service personnel.

C. TROUBLESHOOTING CHARTS

THIS GUIDE SHOULD BE USED IN THE CASE OF A STOPPED OR MANFUNCTIONED ECM BLOWER MOTOR. THE FOLLOWING SHOULD HELP ESTABLISH THE TYPE OF MALFUNCTION OR DEVIATION FROM THE NORMAL BLOWER OPERATION.

TO USE THIS DIAGRAM, YOU JUST NEED TO FOLLOW THE INSTRUCTIONS IN THE BOXES.

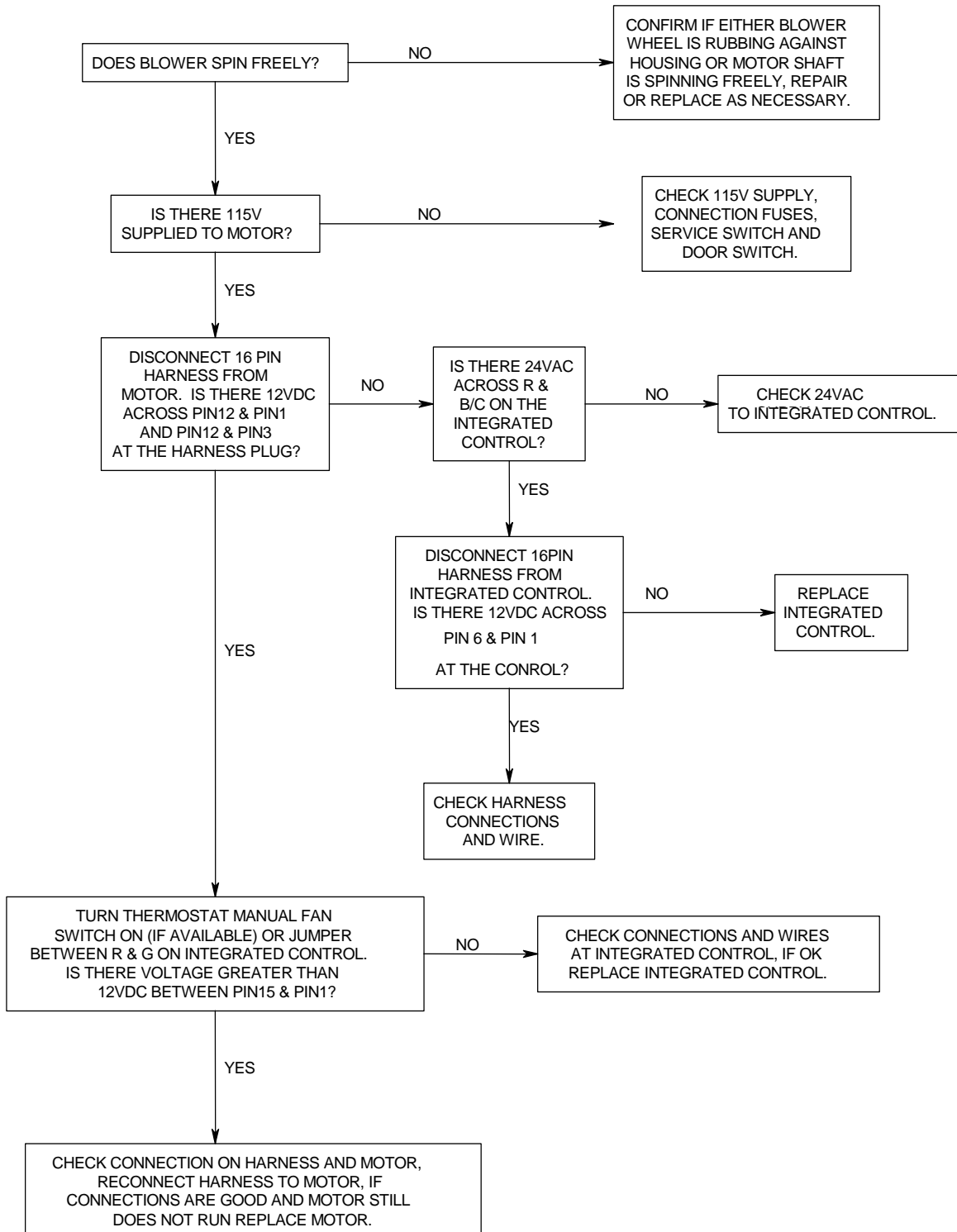

All installations and services must be performed by qualified service personnel.

Sequence of Operation

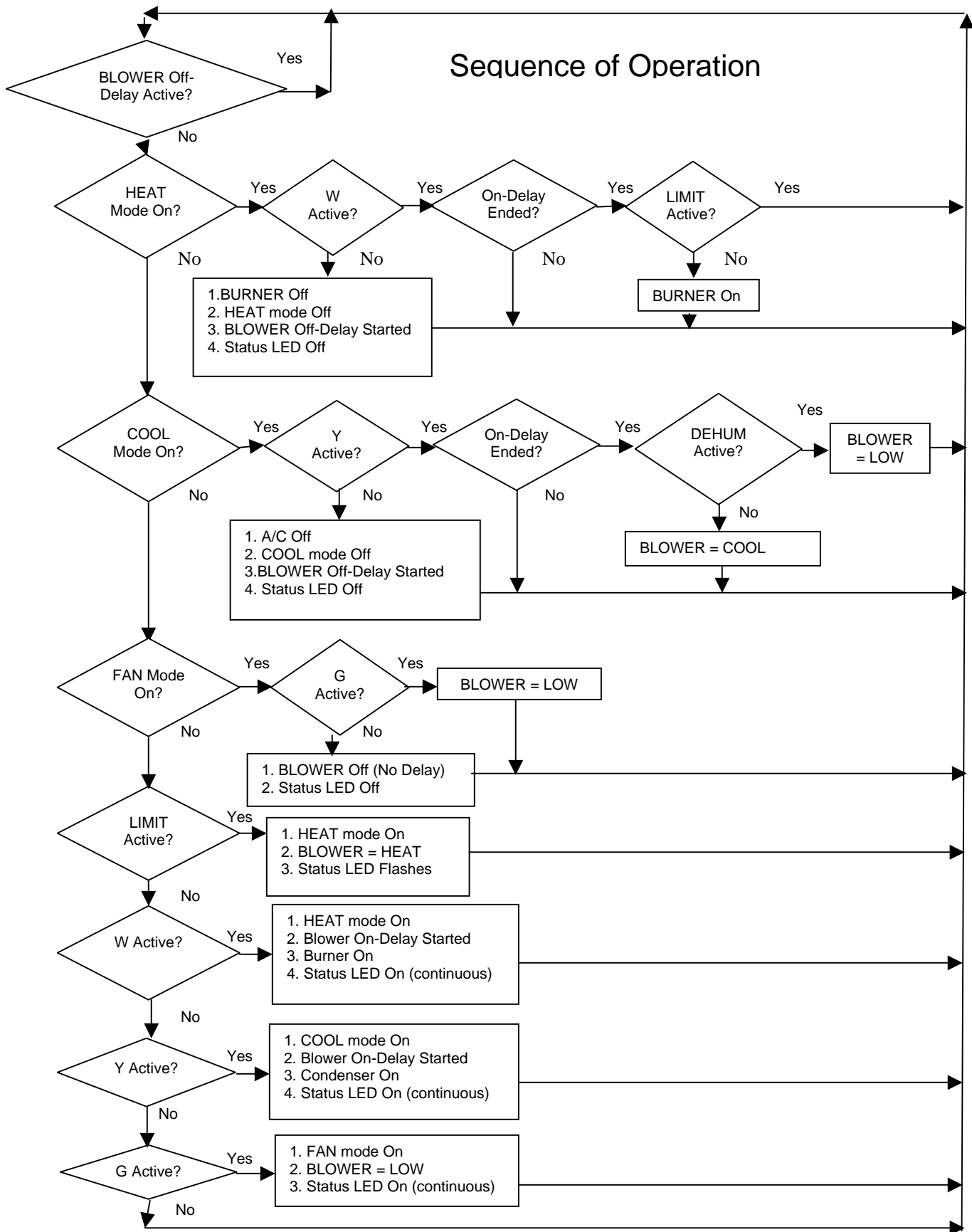

All installations and services must be performed by qualified service personnel.

Sequence of Operation Glossary

Inputs: LIMIT - 120vac power from the High Limit Switch used to power the burner.
W - Switched 24vac indicating a Heat call from the thermostat.
Y - Switched 24vac indicating a Cool call from the thermostat.
G - Switched 24vac indicating a call for blower operation from the thermostat.
DEHUM - Switched 24vac indicating a call for Dehumidification from a de-humidistat.

2 Stage Control

Inputs: LIMIT - 120vac power from the High Limit Switch used to power the burner.
W1 - Switched 24vac indicating a Heat call from the thermostat. (Low fire)
W2 - Switched 24vac indicating a Heat call from the thermostat. (High fire)
Y - Switched 24vac indicating a Cool call from the thermostat.
G - Switched 24vac indicating a call for blower operation from the thermostat.
DEHUM - Switched 24vac indicating a call for Dehumidification from a de-humidistat.

NOTE: 2-Stage T-stat
W1 – Low Fire
W2 – High Fire
Connect 2-Stage T-stat to both W1 and W2.
Single Stage T-stat
W2
Connect single stage T-stat to W2 only.

BLOWER Speeds:

HEAT - The Heating Blower speed selected by positions 1, 2 & 3 of SW1 (CFM tables on page 4)
COOL - The Cooling Blower speed selected by positions 4, 5 & 6 of SW1 (CFM tables on page 4)
LOW - The LOW Blower speed selected by positions 4, 5 & 6 of SW1 (CFM tables on page 4)

ECM – PSC Replacement

In an emergency situation, a defective ECM motor can be replaced with a PSC motor to provide temporary circulating air flow for heating or cooling. This is done by replacing the ECM motor in the motor mounting bracket with a PSC motor of similar Horsepower. Wire the common lead (typically white) of the replacement PSC motor to the neutral (common) terminal on the fan control board (N - 1 through 7). Connect the high-speed replacement PSC motor lead (typically black) to the EAC terminal on the fan control board. The EAC contact is energized with 115VAC any time the control board is calling for fan operation whether in heating or cooling mode. This replacement should be only used in emergency situations and only until a replacement ECM motor can be obtained and reinstalled.