



OIL FIRED UPFLOW FURNACE SPECIFICATIONS

MODEL NO.	OH6FX072DV4R			
HEATING CAPACITY	LOW CAPACITY		HIGH CAPACITY	
	Low Fire	High Fire	Low Fire	High Fire
HEAT INPUT RATE (BTUH)	70,000	85,000	85,000	106,250
OUTPUT BTUH ¹	61,500	74,000	74,000	91,000
SEASONAL EFFICIENCY ²	87.3		86.4	
LARGEST REC A/C ³	4 tons		4 tons	
NOMINAL TEMP RISE	64°	64°	64°	64°
HEAT EXCHANGE AREA				
CASING HEIGHT (IN.):	45"			
CASING WIDTH (IN.):	20"			
CASING DEPTH (IN.):	30"			
NOMINAL FLUE OUTLET DIA.	5"			
APPROX SHIPPING WEIGHT	250 lbs.			
APPROVAL AGENCY	U.L.			
QTY AND SIZE OF PERMANENT FILTERS	(1) 24-3/4" x 15-3/4"			
ELECTRICAL REQUIREMENTS	120 / 60 / 1			
MAX FUSE SIZE ECM	15			
TOTAL CURRENT (AMPS) ECM	12.1			
HEIGHT FROM FLOOR TO CENTER OF FLUE (FRONT FLUE) (REAR FLUE)	40 3/4"			
SUPPLY AIR OUTLET SIZE (W-IN. X D-IN.)	18" x 19"			
RETURN AIR DUCTWORK CONNECTION FLANGE SIZE ON FILTER RACK (D-IN. X H-IN.)	24-1/2" x 15"			
RETURN AIR INLET OPENING SIZE IN SIDE CASING TO BE CUT-OUT BY DEALER (D-IN. X H-IN.)	23" X 14"			
ACCESSORY ITEMS				
PROGRAMMABLE T-STAT	350866			
BLOCKED VENT KIT ⁴	AOPS2687			

- SEE NEXT PAGE FOR MORE DATA -

¹ OUTPUT BTUH BASED ON ANNUAL FUEL UTILIZATION EFFICIENCY RATED BY MANUFACTURER.

² SEASONAL EFFICIENCY (ALSO CALLED AFUE - ANNUAL FUEL UTILIZATION EFFICIENCY) RATINGS ARE BASED ON TESTS FOLLOWING U.S. DEPARTMENT OF ENERGY TEST PROCEDURES.

³ TO PERMIT LARGEST RECOMMENDED AIR CONDITIONING (AT .5 STATIC PRESSURE), SELECTION OF THE HIGHEST MOTOR SPEED IS REQUIRED.

⁴ NOT TO BE USED IN SIDEWALL VENT APPLICATION, USE ONLY WHEN CHIMNEY VENTED.

Model Number Digit	1	2	3	4	5	6	7	8	9	10	11	12
	Fuel	Configuration	Heat Exchanger Identifier	Flue	Design Change	Capacity	Capacity	Capacity	Blower Type	Clg Airflow Cap.	Clg Airflow Cap.	Burner
Oil Furnace Model Nomenclature Example Model Numbers	O	H	6	F	X	0	7	2	D	V	4	R
O = Oil	O											
H = Highboy		H										
6 = Heat Exchanger Size Identifier			6									
F = Front				F								
X= 2 Stage					X							
Heating Capacity MBTUH (000's) with factory installed nozzle						0	7	2				
D = Direct Drive									D			
Clg. Airflow Variable Speed (ECM) V4= 4tons										V	4	
R = Riello												R

- SEE NEXT PAGE FOR MORE DATA -

OIL FIRED UPFLOW FURNACE SPECIFICATIONS

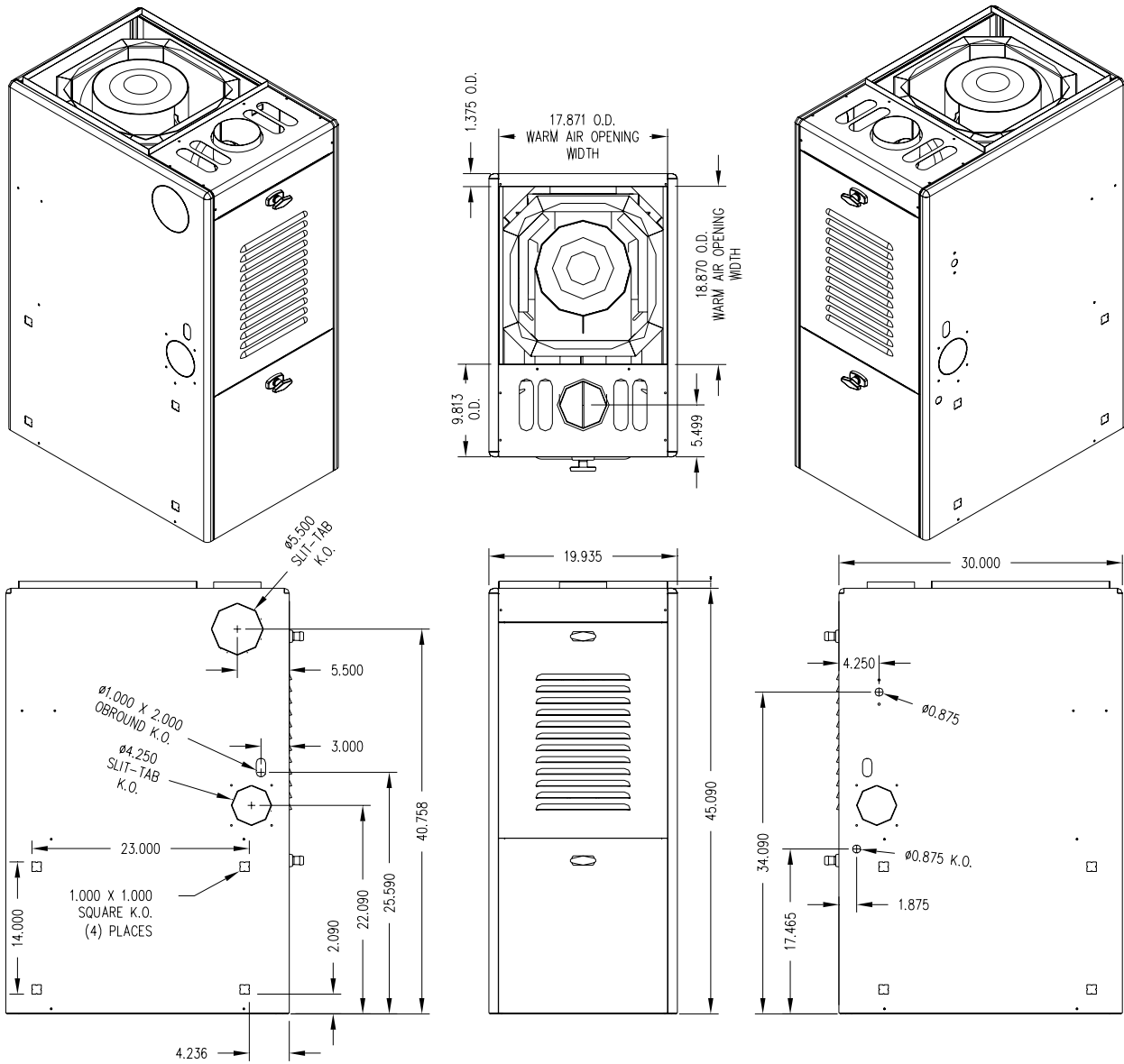

FILTER RACK SPECIFICATIONS

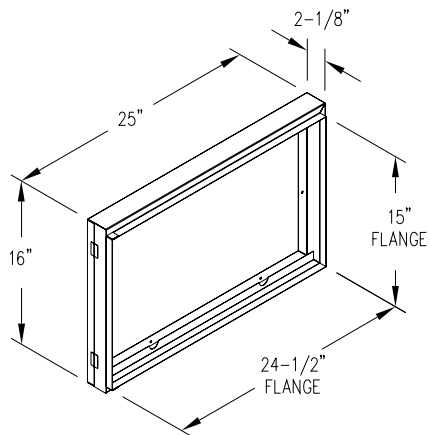

- SEE NEXT PAGE FOR MORE DATA -

OIL FIRED UPFLOW FURNACE SPECIFICATIONS

BLOWER DATA:	OH6FX072DV4
BLOWER MODEL¹	DD 100-9R
MOTOR H.P.	¾ HP Variable Speed
MOTOR TYPE	ECM
HIGH SPEED AIRFLOW (SCFM) @ 0.5 IN. W.G. EXTERNAL STATIC PRESSURE:	1600
Diameter x Width	10 x 9

BURNER DATA	RIELLO "G5D"	
AIR TUBE LENGTH (IN.)	4 ½"	
BURNER HEAD TYPE:	Fixed	
FUEL TYPE:	#2	
NOZZLE RATING (GPH):	70-45° W	50-45° W
SPRAY ANGLE (DEG.):	45°	45°
SPRAY PATTERN:	W	W
OIL PUMP PRESSURE (PSIG):	130 / 170	130 / 170
COMBUSTION CHAMBER TYPE:	REFRACTORY (HARD CERAMIC)	

CLEARANCES	
	MINIMUM CLEARANCES TO COMUSTIBLE MATERIALS:
SIDES	0"
FRONT (SERVICE ACCESS)	(Clearance to Combustibles) 6" / 24" (Service)
REAR	0"
FLUE	7"
TOP PLENUM	1"
SIDES PLENUM	1"

¹ DD = DIRECT DRIVE

OIL FIRED DOWNFLOW FURNACE SPECIFICATIONS

HEATING AIR FLOW / TEMPERATURE RISE

		LOW CAPACITY		HIGH CAPACITY	
FAN CONTROL SW 1 SWITCH SETTINGS	BTUH	LOW FIRE 60,000	HI FIRE 72,000	LOW FIRE 72,000	HI FIRE 90,000
	HEATING CFM	APPROX. CFM/RISE (°F)	APPROX. CFM/RISE (°F)	APPROX. CFM/RISE (°F)	APPROX. CFM/RISE (°F)
3 – OFF 2 – OFF 1 – OFF	740	592 / 94°	740 / 90°	592 / 113°	740 / 113°
3 – OFF 2 – OFF 1 – ON	812	650 / 85°	812 / 82°	650 / 103°	812 / 103°
3 – OFF 2 – ON 1 – OFF	883	706 / 79°	883 / 75°	706 / 94°	883 / 94°
3 – OFF 2 – ON 1 – ON	968	744 / 72°	968 / 69°	774 / 86°	968 / 86°
3 – ON 2 – OFF 1 – OFF	1054	843 / 66°	1054 / 63°	843 / 79°	1054 / 79°
3 – ON 2 – OFF 1 – ON	1153	922 / 60°	1153 / 58°	922 / 72°	1153 / 72°
FACTORY SW1 SWITCH SETTINGS 3 – ON 2 – ON 1 – OFF	1267	1013 / 55°	1267 / 53°	1013 / 66°	1267 / 66°
3 – ON 2 – ON 1 – ON	1424	1139 / 49°	1424 / 47°	1139 / 59°	1424 / 59°

= Recommended heating speed setting

Cooling Speed set-ups

Fan Control SW 1 Switch Settings	Air Flow		
	Clg. Tonnage	Cool	Continuous
6-OFF 5-OFF 4-OFF	2	799	500
6-OFF 5-OFF 4-ON	2.5	1017	508
6-OFF 5-ON 4-OFF	3	1210	605
6-OFF 5-ON 4-ON	3.5	1404	702
FACTORY SW1 SWITCH SETTINGS 6-ON 5-OFF 4-OFF	4	1622	799

- SEE NEXT PAGE FOR MORE DATA -

OIL FIRED UPFLOW FURNACE SPECIFICATIONS

A/C EVAPORATOR COIL APPLICATION

CONDENSER	13 SEER				
FURNACE					
	AC13241B1	AC13301B1	AC13361B1	AC13421B1	AC13481B1 AC13483B1
	UPFLOW (CASED) COIL				
OH6FX072DV4	12C2436AG19	12C2436AG19	12C3642AG19	12C3642AG19	12C4848HH21
CONDENSER	14 SEER				
FURNACE					
	AC14241C1	AC14301C1	AC14361C1	AC14421C1	AC14481C1 AC14483C1
	UPFLOW (CASED) COIL				
OH6FX072DV4	12C2436AG19	12C2436AG19	12C3642AG19	12C3642AG19	12C4848HH21