



**GAS-FIRED MOBILE HOME FURNACE
DOWN FLOW & DIRECT VENT (SEALED COMBUSTION)
FURNACE SPECIFICATIONS**

MODEL NO.	GMD1-60		GMD1-80	
HEAT INPUT RATE (BTUH)	60,000		80,000	
OUTPUT (BTUH)¹	49,000		65,000	
SEASONAL EFFICIENCY²	82		81	
LARGEST REC A/C³	2.5 TONS		2.5 TONS (AS SHIPPED) 3 TONS WITH UPGRADE KIT	
FUEL	NAT	LP	NAT	LP
BURNER ORIFICE	#38	#52	2.45mm	#53
GAS SUPPLY PRESSURE (IN W.G.)				
MINIMUM REQUIRED	5.5	11	5.5	11
MAXIMUM ALLOWED	14.0	14.0	14.0	14.0
GAS MANIFOLD PRESSURE (IN W.G.)	10±0.3	3.5±0.3	10±0.3	3.5±0.3
NOMINAL TEMP. RISE	60°		70°	
VENT PIPE SIZE (IN.)			4"	
CASING HEIGHT (IN.)			57"	
CASING WIDTH (IN.)			18"	
CASING DEPTH (IN.)			25 ½"	
APPROX. SHIPPING WEIGHT (LBS.)			165 LBS.	
APPROVAL AGENCY			ETL	
SIZE OF PERM. FILTER			18" X 24"	
ELECTRICAL REQUIREMENTS			115 VAC/ 60 HZ/ 1 PHASE	
MAX FUSE SIZE			15 AMPS	
TOTAL RATED CURRENT AMPS.			7.15	
SUPPLY AIR OUTLET SIZE (W-IN X D-IN)			12" X 12"	
RETURN AIR INLET OPENING SIZE			14" X 22"	
NOMINAL HEAT ANTICIPATOR SETTING			0.8mA	
	ACCESSORY ITEMS			
PROGRAMMABLE T-STAT			350866	
MOBILE HOME BASE			NO. 70BASE	
COTTAGE BASE			01COT-BASE	
COIL CABINET			CE111S	
3 TON A/C UPGRADE KIT (GMD1-80 ONLY)			AOPS2677	
COIL CABINET FOR 3 TON UPGRADE KIT (GMD1-80 ONLY)			CE211T	
ROOF JACK 12" OR LESS			TRJ-1	
ROOF JACK 13" TO 24"			TRJ-2	
ROOF JACK 25" TO 36"			TRJ-3	
SLOPE ADAPTOR 2-1/2-12			TSA-25	
SLOPE ADAPTOR 3-1/2-12			TSA-30	

- SEE NEXT PAGE FOR MORE DATA -

¹ OUTPUT BTUH BASED ON ANNUAL FUEL UTILIZATION EFFICIENCY RATED BY MANUFACTURER.

² SEASONAL EFFICIENCY (ALSO CALLED AFUE-ANNUAL FUEL UTILIZATION EFFICIENCY) RATINGS ARE BASED ON TESTS FOLLOWING U.S. DEPARTMENT OF ENERGY TEST PROCEDURES.

³ TO PERMIT LARGEST RECOMMENDED AIR CONDITIONING (AT .5 STATIC PRESSURE), SELECTION OF THE HIGHEST MOTOR SPEED IS REQUIRED.

MODEL NUMBER DIGIT	1	2	3	4	5	6		7
	FUEL	MOBILE HOME	CONFIGURATION	VERSION		INPUT		FUEL TYPE
GAS FURNACE MODEL NOMENCLATURE EXAMPLE MODEL NUMBERS	G	M	D	1	-	6	0	N
	G	M	D	1	-	8	0	N
G= GAS	G							
M= MOBILE HOME		M						
D= DOWNFLOW			D					
1= VERSION				1				
					-			
INPUT IN MBTUH (1000'S)						6	0	
N= NATURAL GAS L= LIQUID PROPANE								N

- SEE NEXT PAGE FOR MORE DATA -

CLEARANCES TO COMBUSTIBLES

MODELS: GMD1-60 / GMD1-80	CLOSET	ALCOVE
FRONT	6"	18"
BACK	0"	0"
SIDES	0"	0"
ROOF JACK	0"	0"
VENT CONNECTOR	6"	6"
TOP	1"	1"
PLENUM SIDES	1"	1"
TOP AND SIDES OF DUCT	1"	1"
BOTTOM DUCT	1"	1"

BLOWER DATA

FURNACE MODEL	GMD1-60	GMD1-80	*GMD1-80
BLOWER MODEL	10-7R	10-9R	12-9T
MOTOR H.P.	1/3 HP	1/3 HP	1/2 HP
NO. OF SPEEDS	4	4	4
HIGH SPEED AIRFLOW (SCFM) @ 0.5 IN. W.G. EXTERNAL STATIC PRESSURE	1000	1000	1175
DIAMETER X WIDTH	10 X 7	10 X 9	12 X 9

*A/C UPGRADE KIT (SEE ACCESSORY ITEMS)

- SEE NEXT PAGE FOR MORE DATA -

GAS FIRED MOBILE HOME FURNACE SPECIFICATIONS

GMD1-60

ALTERATIONS REQ'D FOR A/C @ DESIGN EXTERNAL STATIC PRESSURE		
COOLING UNIT	HTG Speed	Recommended CLG Speed
24,000	LOW	MEDIUM LOW
30,000	LOW	HIGH

Speed Tap \ Static Pressure	Furnace Airflow (CFM) vs. External Static pressure (in. WC.)						
	0.1	0.2	0.3	0.4	0.5	0.6	0.7
Low	779	759	747	727	694	660	581
ML	925	907	886	842	809	762	709
MH	1148	1096	1058	991	934	876	827
High	1271	1207	1147	1096	1029	954	890

Speed Tap \ Static Pressure	Temperature Rise vs. External Static Pressure (in. WC.)						
	0.1	0.2	0.3	0.4	0.5	0.6	0.7
Low	58	60	61	63	66	69	78
ML	49	50	51	54	56	60	64
MH	40	42	43	46	49	52	55
High	36	38	40	42	44	48	51

Speed Tap \ Static Pressure	Furnace Motor Current Draw (Amps) vs. External Static pressure (in. WC.)						
	0.1	0.2	0.3	0.4	0.5	0.6	0.7
Low	2.56	2.45	2.37	2.24	2.11	1.99	1.81
ML	3.16	2.94	2.81	2.63	2.51	2.33	2.2
Med	3.73	3.47	3.31	3.12	2.94	2.76	2.64
MH	3.73	3.47	3.31	3.12	2.94	2.76	2.64
High	4.4	4.17	3.96	3.8	3.63	3.45	3.31

Speed Tap \ Static Pressure	Furnace Motor Watts vs. External Static pressure (in. WC.)						
	0.1	0.2	0.3	0.4	0.5	0.6	0.7
Low	259	250	244	235	224	214	198
ML	327	309	300	282	271	255	243
MH	408	381	364	344	327	307	295
High	484	464	442	424	405	384	369

= Recommended operation range

- SEE NEXT PAGE FOR MORE DATA -

GAS FIRED MOBILE HOME FURNACE SPECIFICATIONS

GMD1-80

ALTERATIONS REQ'D FOR A/C @ DESIGN EXTERNAL STATIC PRESSURE		
COOLING UNIT	HTG Speed	Recommended CLG Speed
24,000	MED. LOW	MED. LOW /MED. HIGH
30,000	MED. LOW	HIGH

Speed Tap \ Static Pressure	Furnace Airflow (CFM) vs. External Static pressure (in. WC.)						
	0.1	0.2	0.3	0.4	0.5	0.6	0.7
Low	784	758	722	682	629	578	506
ML	933	915	886	813	762	711	642
MH	1155	1114	1063	1000	902	817	766
High	1281	1226	1162	1105	1031	919	829

Speed Tap \ Static Pressure	Temperature Rise vs. External Static Pressure (in. WC.)						
	0.1	0.2	0.3	0.4	0.5	0.6	0.7
Low	77	79	83	88	95	104	119
ML	64	66	68	74	79	84	93
MH	52	54	56	60	67	73	78
High	47	49	52	54	58	65	72

Speed Tap \ Static Pressure	Furnace Motor Current Draw (Amps) vs. External Static pressure (in. WC.)						
	0.1	0.2	0.3	0.4	0.5	0.6	0.7
Low	2.61	2.5	2.36	2.24	2.13	2.05	1.93
ML	3.12	3.02	2.91	2.7	2.55	2.43	2.28
MH	3.63	3.49	3.31	3.17	2.93	2.79	2.69
High	4.27	4.14	3.97	3.83	3.68	3.45	3.32

Speed Tap \ Static Pressure	Furnace Motor Watts vs. External Static pressure (in. WC.)						
	0.1	0.2	0.3	0.4	0.5	0.6	0.7
Low	260	255	245	236	227	218	208
ML	321	315	306	285	275	266	251
MH	395	382	365	349	327	311	300
High	475	461	444	428	408	385	371

= Recommended operation range

- SEE NEXT PAGE FOR MORE DATA -

GAS FIRED MOBILE HOME FURNACE SPECIFICATIONS

GMD1-80 (3 TON A/C UPGRADE KIT)

ALTERATIONS REQ'D FOR A/C @ DESIGN EXTERNAL STATIC PRESSURE		
COOLING UNIT	HTG Speed	Recommended CLG Speed
24,000	LOW	MED. LOW
30,000	LOW	MED. HIGH
36,000	LOW	HIGH

Speed Tap \ Static Pressure	Furnace Airflow (CFM) vs. External Static pressure (in. WC.)						
	0.1	0.2	0.3	0.4	0.5	0.6	0.7
Low	829	809	781	748	709	677	609
ML	1022	995	964	926	888	825	781
MH	1216	1181	1142	1093	1041	987	920
High	1363	1315	1266	1218	1120	1115	1055

Speed Tap \ Static Pressure	Temperature Rise vs. External Static Pressure (in. WC.)						
	0.1	0.2	0.3	0.4	0.5	0.6	0.7
Low	72	74	77	80	85	89	99
ML	59	60	62	65	68	73	77
MH	49	51	53	55	58	61	65
High	44	46	47	49	51	54	57

Speed Tap \ Static Pressure	Furnace Motor Current Draw (Amps) vs. External Static pressure (in. WC.)						
	0.1	0.2	0.3	0.4	0.5	0.6	0.7
Low	3.07	2.97	2.85	2.74	2.62	2.54	2.42
ML	3.76	3.57	3.4	3.27	3.17	3.03	2.89
MH	4.38	4.22	4.12	3.93	3.77	3.6	3.45
High	5.15	4.97	4.84	4.71	4.58	4.47	4.33

Speed Tap \ Static Pressure	Furnace Motor Watts vs. External Static pressure (in. WC.)						
	0.1	0.2	0.3	0.4	0.5	0.6	0.7
Low	306	300	293	285	276	269	258
ML	392	375	363	350	342	327	314
MH	470	457	445	428	411	397	379
High	563	547	529	517	501	491	474

= Recommended operation range

- SEE NEXT PAGE FOR MORE DATA -

GAS FIRED MOBILE HOME FURNACE SPECIFICATIONS GMD1**

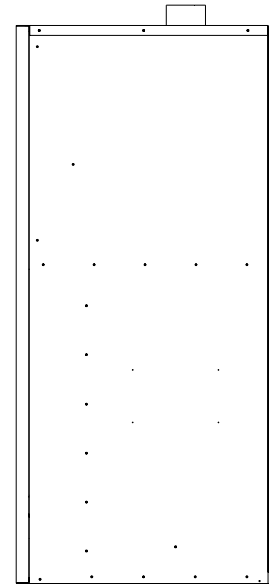
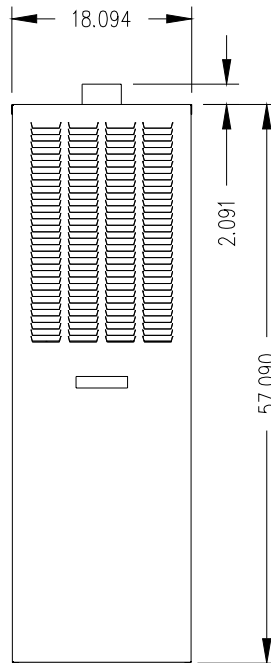
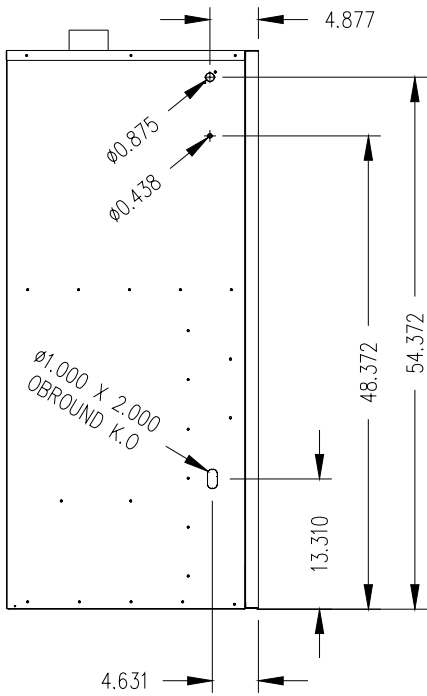
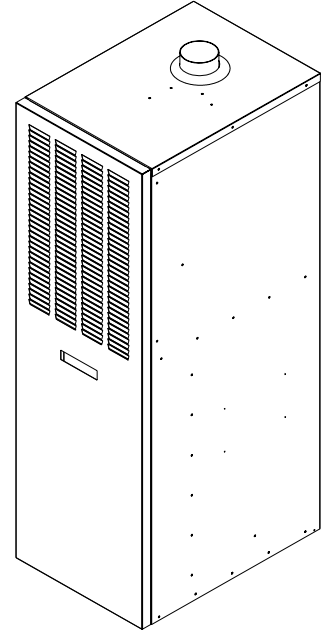
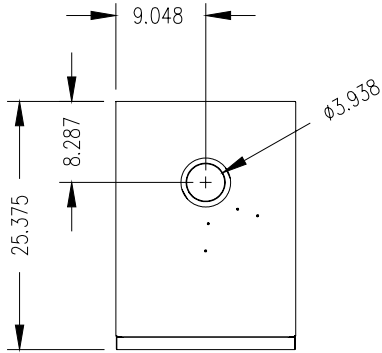
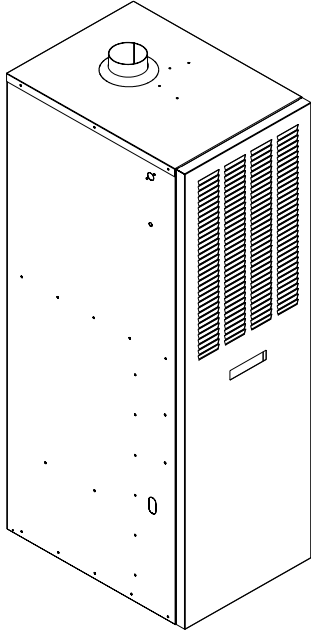

- SEE NEXT PAGE FOR MORE DATA -

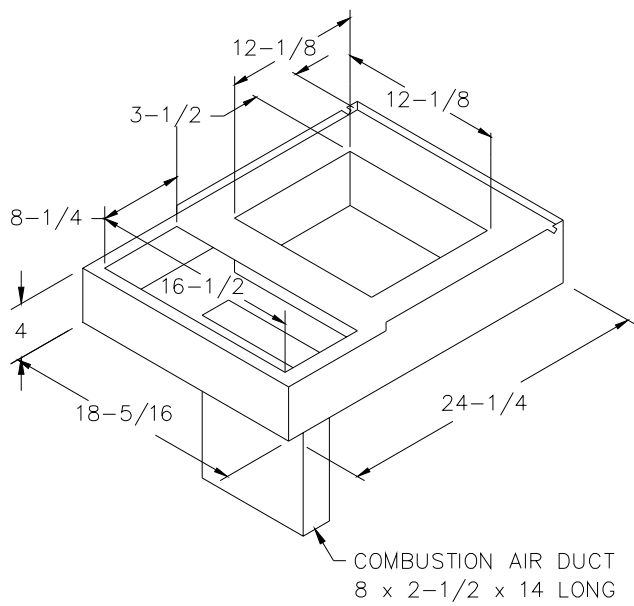

Combustible Floor Base Model: 70-BASE

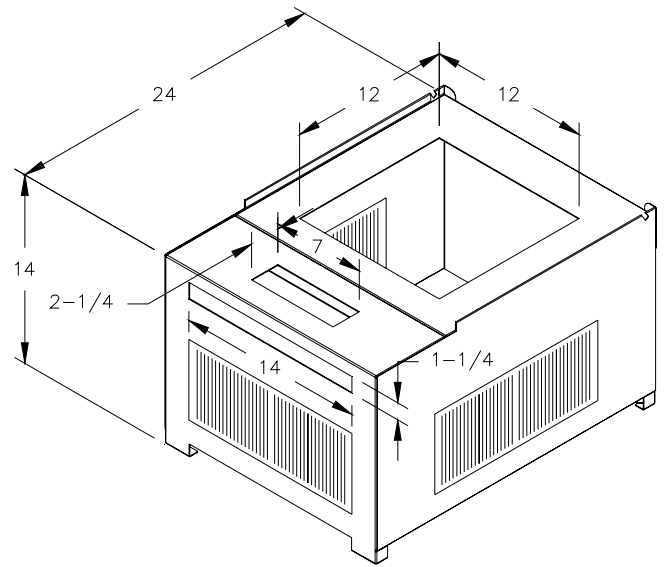

Cottage Base Model: 01COT-BASE

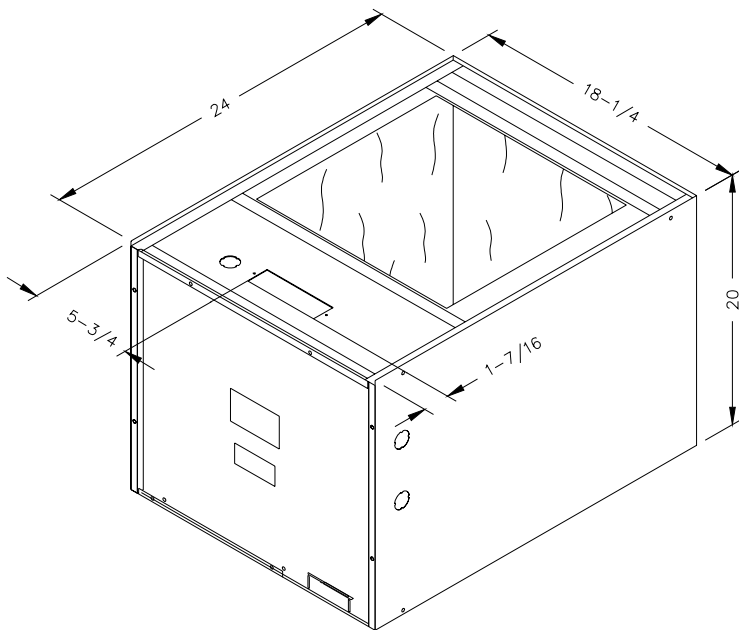

Coil Cabinet Model: CE111S

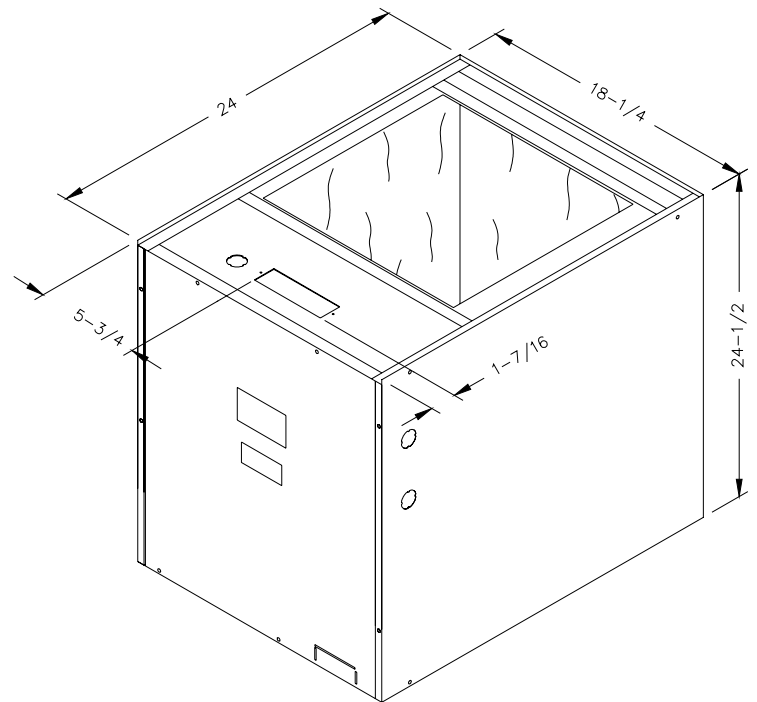

Coil Cabinet Model: CE211T

- SEE NEXT PAGE FOR MORE DATA -

GAS FIRED MOBILE HOME FURNACE SPECIFICATIONS
A/C EVAPORATOR COIL APPLICATION

CONDENSER FURNACE	PREMIERE		
	AC14241C1	AC14301C1	AC14361C1 ⁴
COUNTERFLOW			
GMD1-60	12U2430AG15	12U2430AG15	N/A
COIL CABINENT	CE111S	CE111S	N/A
GMD1-80	12U2430AG15	12U2430AG15	12U3648AG17 ⁴
COIL CABINENT	CE111S	CE111S	CE211T ⁴

- SEE NEXT PAGE FOR MORE DATA -

⁴ 3 TON UPGRADE KIT REQUIRED

GMD1** SPECIFICATIONS

