



GAS HIGH EFFICIENCY UPFLOW FURNACE SPECIFICATIONS

MODEL NO.	CHB1-50N	CHB1-75N	CHB1-100N	CHB1-125N
FUEL	GAS NAT/LP	GAS NAT/LP	GAS NAT/LP	GAS NAT/LP
INPUT BTUH	50,000	75,000	100,000	125,000
OUTPUT BTUH ¹	47,000	71,000	94,000	116,000
SEASONAL EFFICIENCY ²	95.0%	93.0%	95.0%	93.0%
LARGEST REC A/C ³	2 T	3.5 T	4 T	5 T
NOMINAL TEMP RISE	70°	70°	70°	70°
APPROX EFFECTIVE HEATING SURFACE	5400 SQ IN.	5950 SQ IN	6500 SQ IN	7025 SQ IN
APPROX SHIPPING WEIGHT	185 LBS	200 LBS	225 LBS	243 LBS
APPROVAL AGENCY	CSA	CSA	CSA	CSA
DIA OF FLUE (PVC)	2"	2"	3"	3"
DIA OF COMBUSTION AIRINTAKE (PVC)	2"	2"	3"	3"
QTY AND SIZE OF PERMANENT FILTERS	ONE 1" x 25" x 16"	ONE 1" x 25" x 16"	ONE 1" x 25" x 16"	ONE 1" x 25" x 20"
ELECTRICAL RATING	115V 60HZ 1PH	115V 60HZ 1PH	115V 60HZ 1PH	115V 60HZ 1PH
MAX FUSE SIZE	15 AMP	15 AMP	15 AMP	20 AMP
ACCESSORY ITEMS				
FILTER RACK	AOPS7547	AOPS7547	AOPS7547	AOPS7375
PROGRAMMABLE T-STAT STD/DELUXE	350164 / 350165	350164 / 350165	350164 / 350165	350164 / 350165
CONCENTRIC VENT KIT	AOPS7488	AOPS7488	AOPS7489	AOPS7489
SIDEWALL VENT CAP	370191	370191	370191	370191
NEUTRALIZER KIT	320095	320095	320095	320095
CONDENSATE PUMP	350225	350225	350225	350225
NAT. CONVERSION KIT	AOPS7665	AOPS7665	AOPS7665	AOPS7665
LP CONVERSION KIT	AOPS7677	AOPS7678	AOPS7679	AOPS7664
FURNACE PARTS KIT	AOPS7429	AOPS7429	AOPS7429	AOPS7429

¹ OUTPUT BTUH BASED ON ANNUAL FUEL UTILIZATION EFFICIENCY RATED BY MANUFACTURER.

² SEASONAL EFFICIENCY (ALSO CALLED AFUE - ANNUAL FUEL UTILIZATION EFFICIENCY) RATINGS ARE BASED ON TESTS FOLLOWING U.S. DEPARTMENT OF ENERGY TEST PROCEDURES.

³ TO PERMIT LARGEST RECOMMENDED AIR CONDITIONING (AT .5 STATIC PRESSURE), SELECTION OF THE HIGHEST MOTOR SPEED IS REQUIRED.

ALL SPECIFICATIONS ARE SUBJECT TO CHANGE WITHOUT NOTICE.

FURNACE NOMENCLATURE					
C	H	B	1	-50	N
C = CONDENSING	H = HIGHBOY (UPFLOW) D = COUNTERFLOW / HORIZONTAL	A = SERIES B = SERIES X = 2 STAGE, ECM	REVISION LEVEL	INPUT 50,000	NATURAL GAS

SEE NEXT PAGE FOR MORE DATA -

GAS HIGH-EFFICIENCY UPFLOW FURNACE SPECIFICATIONS

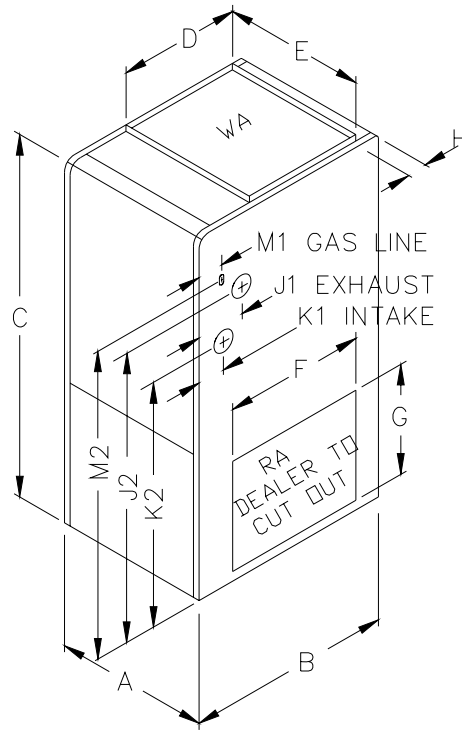

DIM / MODEL	CHB1-50N	CHB1-75N	CHB1-100N	CHB1-125N
A	17"	17"	21"	24"
B	27-1/2"	27-1/2"	27-1/2"	27-1/2"
C	44-1/4"	44-1/4"	44-1/4"	44-1/4"
D	18"	18"	18"	18"
E	15"	15"	19"	22"
F ¹	23"	23"	23"	23"
G ¹	14"	14"	14"	14"
H	1-1/4"	1-1/4"	1-1/4"	1-1/4"
J1 L	2-7/8"	2-7/8"	2-7/8"	2-7/8"
J1 R	6-1/2"	6-1/2"	6-1/2"	6-1/2"
J2 L	33"	33"	33"	33"
J2 R	30-1/2"	30-1/2"	30-1/2"	30-1/2"
K1 L	6-1/2"	6-1/2"	6-1/2"	6-1/2"
K1 R	2-7/8"	2-7/8"	2-7/8"	2-7/8"
K2 L	30-1/4"	30-1/4"	30-1/4"	30-1/4"
K2 R	27"	27"	27"	27"
M1 L	5-5/8"	5-5/8"	5-5/8"	5-5/8"
M1 R	2-3/4"	2-3/4"	2-3/4"	2-3/4"
M2 L	33"	33"	33"	33"
M2 R	33"	33"	33"	33"

¹ DIMENSIONS F & G ARE THE RETURN AIR CUT OUT DIMENSIONS. THESE ARE SMALLER THAN THE RETURN AIR DUCT DIMENSIONS AS THEY ALLOW FOR A 1" MOUNTING FLANGE. DUCTWORK SHOULD BE SIZED BY THE FILTER SIZE.

GAS HIGH-EFFICIENCY UPFLOW FURNACE SPECIFICATIONS

FILTER RACK SPECIFICATIONS

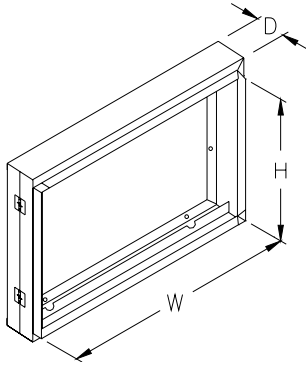

FILTER RACK DIMENSIONS			
	RETURN AIR PLENUM FLANGE		DEPTH OF RACK
MODELS	H	W	D
AOPS7547	15"	24-1/2"	2-1/8"
AOPS7375	19"	23-1/2"	6-1/8"

BLOWER DATA:	CHB1-50N	CHB1-75N	CHB1-100N	CHB1-125N
BLOWER MODEL ²	10-9R DD	10-9R DD	10-10R DD	12-11T DD
MOTOR H.P.	1/5 - 3SP	1/3 - 4SP	1/2 - 4SP	3/4 - 4SP

BURNER DATA				
BURNER TYPE	INSHOT	INSHOT	INSHOT	INSHOT
NO. PER UNIT	2	3	4	5
MAX INLET PRESSURE (NAT)	14" WC	14" WC	14" WC	14" WC
MIN INLET PRESSURE (NAT)	4.5" WC	4.5" WC	4.5" WC	4.5" WC
MAX INLET PRESSURE (LP)	14" WC	14" WC	14" WC	14" WC
MIN INLET PRESSURE (LP)	11" WC	11" WC	11" WC	11" WC
NORMAL MANIFOLD PRESS (NAT)	3.5" WC	3.5" WC	3.5" WC	3.5" WC
NORMAL MANIFOLD PRESS (LP)	10" WC	10" WC	10" WC	10" WC
ORIFICE SIZE (NAT.)	0.0935" (#42)	0.0935" (#42)	0.0935" (#42)	0.0935" (#42)
DIA. (D.M.S.) (L.P.)	0.0591" (1.5mm)	0.0591" (1.5mm)	0.0591" (1.5mm)	0.0591" (1.5mm)

CLEARANCES				
	MINIMUM CLEARANCES TO COMBUSTIBLE MATERIALS:			
SIDES	0"	0"	0"	0"
FRONT (SERVICE ACCESS)	6" (24")	6" (24")	6" (24")	6" (24")
REAR	0"	0"	0"	0"
FLUE	0"	0"	0"	0"
TOP	1"	1"	1"	1"

² DD = DIRECT DRIVE

GAS HIGH-EFFICIENCY UPFLOW FURNACE SPECIFICATIONS CHB1-50N

ALTERATIONS REQ'D FOR A/C @ DESIGN EXTERNAL STATIC PRESSURE		
COOLING UNIT	HTG Speed	Recommended CLG Speed
24,000	LOW	HIGH

Speed Tap \ Static Pressure	Furnace Airflow (CFM) vs. External Static pressure (in. WC.)						
	0.1	0.2	0.3	0.4	0.5	0.6	0.7
Low	672	616	550	474	397	320	266
Med	993	941	901	847	778	680	579
High	1116	1064	1021	961	875	792	683

Speed Tap \ Static Pressure	Temperature Rise vs. External Static Pressure (in. WC.)						
	0.1	0.2	0.3	0.4	0.5	0.6	0.7
Low	64	70	78	91	109	135	162
Med	43	46	48	51	55	63	74
High	39	40	42	45	49	54	63

Speed Tap \ Static Pressure	Blower Motor Current Draw (Amps) vs. External Static pressure (in. WC.)						
	0.1	0.2	0.3	0.4	0.5	0.6	0.7
Low	1.5	1.5	1.4	1.4	1.3	1.2	1.2
Med	2.8	2.6	2.6	2.5	2.4	2.3	2.2
High	3.2	3.1	3.0	2.9	2.8	2.6	2.5

Speed Tap \ Static Pressure	Blower Motor Watts vs. External Static pressure (in. WC.)						
	0.1	0.2	0.3	0.4	0.5	0.6	0.7
Low	166	162	157	152	146	140	134
Med	307	294	291	284	270	255	243
High	362	348	344	332	311	297	280

= Recommended operation range

SEE NEXT PAGE FOR MORE DATA -

GAS HIGH-EFFICIENCY UPFLOW FURNACE SPECIFICATIONS CHB1-75N

ALTERATIONS REQ'D FOR A/C @ DESIGN EXTERNAL STATIC PRESSURE		
COOLING UNIT	HTG Speed	Recommended CLG Speed
24,000	MED-LOW	MED-LOW
30,000	MED-LOW	MED-HIGH
36,000	MED-LOW	HIGH
42,000	MED-LOW	HIGH

Speed Tap \ Static Pressure	Furnace Airflow (CFM) vs. External Static pressure (in. WC.)						
	0.1	0.2	0.3	0.4	0.5	0.6	0.7
Low	768	750	730	695	657	597	527
ML	927	921	896	875	832	784	704
MH	1226	1214	1188	1155	1102	1032	945
High	1556	1512	1462	1394	1331	1254	1152

Speed Tap \ Static Pressure	Temperature Rise vs. External Static Pressure (in. WC.)						
	0.1	0.2	0.3	0.4	0.5	0.6	0.7
Low	84	86	88	93	98	108	123
ML	70	70	72	74	78	82	92
MH	53	53	54	56	59	63	68
High	42	43	44	46	49	52	56

Speed Tap \ Static Pressure	Blower Motor Current Draw (Amps) vs. External Static pressure (in. WC.)						
	0.1	0.2	0.3	0.4	0.5	0.6	0.7
Low	2.7	2.6	2.5	2.4	2.3	2.1	2.0
ML	3.4	3.3	3.2	3.1	2.9	2.8	2.5
MH	4.5	4.3	4.1	3.8	3.6	3.3	3.2
High	5.6	5.3	5.1	4.8	4.6	4.3	4.1

Speed Tap \ Static Pressure	Blower Motor Watts vs. External Static pressure (in. WC.)						
	0.1	0.2	0.3	0.4	0.5	0.6	0.7
Low	264	260	255	248	240	225	214
ML	342	335	327	319	308	295	273
MH	473	461	436	417	393	368	350
High	611	587	563	534	508	481	452

= Recommended operation range

SEE NEXT PAGE FOR MORE DATA -

GAS HIGH-EFFICIENCY UPFLOW FURNACE SPECIFICATIONS CHB1-100N

ALTERATIONS REQ'D FOR A/C @ DESIGN EXTERNAL STATIC PRESSURE		
COOLING UNIT	HTG Speed	Recommended CLG Speed
30,000	LOW	LOW
36,000	LOW	MED-LOW
42,000	LOW	MED-HIGH
48,000	LOW	HIGH

Speed Tap \ Static Pressure	Furnace Airflow (CFM) vs. External Static pressure (in. WC.)						
	0.1	0.2	0.3	0.4	0.5	0.6	0.7
Low	1266	1249	1210	1163	1108	1040	888
ML	1441	1403	1360	1297	1236	1151	1053
MH	1608	1561	1500	1437	1356	1259	1154
High	1832	1758	1688	1603	1530	1425	1322

Speed Tap \ Static Pressure	Temperature Rise vs. External Static Pressure (in. WC.)						
	0.1	0.2	0.3	0.4	0.5	0.6	0.7
Low	68	69	71	74	78	83	97
ML	60	61	63	66	70	75	82
MH	54	55	57	60	63	68	75
High	47	49	51	54	56	60	65

Speed Tap \ Static Pressure	Blower Motor Current Draw (Amps) vs. External Static pressure (in. WC.)						
	0.1	0.2	0.3	0.4	0.5	0.6	0.7
Low	5.2	5.0	4.7	4.5	4.2	3.9	3.5
ML	5.8	5.5	5.3	5.0	4.7	4.4	4.1
MH	6.3	6.1	5.8	5.6	5.2	5.0	4.6
High	7.9	7.6	7.4	7.2	7.0	6.8	6.6

Speed Tap \ Static Pressure	Blower Motor Watts vs. External Static pressure (in. WC.)						
	0.1	0.2	0.3	0.4	0.5	0.6	0.7
Low	534	519	495	474	447	422	379
ML	602	579	557	528	502	473	438
MH	673	644	621	593	561	528	496
High	810	783	756	730	701	674	644

= Recommended operation range

SEE NEXT PAGE FOR MORE DATA -

GAS HIGH-EFFICIENCY UPFLOW FURNACE SPECIFICATIONS CHB1-125N

ALTERATIONS REQ'D FOR A/C @ DESIGN EXTERNAL STATIC PRESSURE		
COOLING UNIT	HTG Speed	Recommended CLG Speed
42,000	LOW	MED-LOW
48,000	LOW	MED-HIGH
60,000	LOW	HIGH

Speed Tap \ Static Pressure	Furnace Airflow (CFM) vs. External Static pressure (in. WC.)						
	0.1	0.2	0.3	0.4	0.5	0.6	0.7
Low	1660	1643	1621	1598	1548	1510	1461
ML	1765	1716	1674	1626	1581	1526	1479
MH	1805	1793	1753	1707	1674	1630	1577
High	2238	2167	2117	2065	1994	1890	1821

Speed Tap \ Static Pressure	Temperature Rise vs. External Static Pressure (in. WC.)						
	0.1	0.2	0.3	0.4	0.5	0.6	0.7
Low	65	66	66	67	70	71	74
ML	61	63	64	66	68	71	73
MH	60	60	61	63	64	66	68
High	48	50	51	52	54	57	59

Speed Tap \ Static Pressure	Blower Motor Current Draw (Amps) vs. External Static pressure (in. WC.)						
	0.1	0.2	0.3	0.4	0.5	0.6	0.7
Low	7.5	7.3	7.1	6.9	6.7	6.5	6.3
ML	8.3	7.8	7.5	7.2	6.9	6.6	6.2
MH	8.3	8.2	7.9	7.8	7.5	7.3	7.0
High	10.6	10.3	10.0	9.8	9.4	9.0	8.7

Speed Tap \ Static Pressure	Blower Motor Watts vs. External Static pressure (in. WC.)						
	0.1	0.2	0.3	0.4	0.5	0.6	0.7
Low	764	750	735	724	703	684	661
ML	844	809	775	750	726	699	664
MH	863	854	832	812	788	768	744
High	1120	1090	1060	1040	999	944	919

= Recommended operation range

SEE NEXT PAGE FOR MORE DATA -

GAS HIGH EFFICIENCY UPFLOW FURNACE SPECIFICATIONS

EVAPORATOR COIL APPLICATION

FURNACE MODEL	CONDENSER MODEL	LINE SET MODEL	EVAPORATOR COIL MODEL	SEER	EER	TOTAL (BTU/HR) HEAT REMOVAL	SENSIBLE HEAT REMOVAL
CHB1-50N	AC14241G2	LS01E-30 LS01E-50	13U2430AB15	13.80	12.30	24,000	0.730
			CA243615	14.00	12.40	24,000	0.733
			13U3030AB15	14.00	12.40	24,000	0.733
			CA303615 ¹	14.40	12.70	25,400	0.739
			13U3036AB17	14.40	12.70	25,400	0.739

¹adapter angles included with coil cabinet

FURNACE MODEL	CONDENSER MODEL	LINE SET MODEL	EVAPORATOR COIL MODEL	SEER	EER	TOTAL (BTU/HR) HEAT REMOVAL	SENSIBLE HEAT REMOVAL
CHB1-75N	AC14241G2	LS01E-30 LS01E-50	13U2430AB15	13.80	12.30	24,000	0.730
			CA243615	14.00	12.40	24,000	0.733
			13U3030AB15	14.00	12.40	24,000	0.733
			CA303615 ¹	14.40	12.70	25,400	0.739
			13U3036AB17	14.40	12.70	25,400	0.739
	AC14301G2	LS01E-30 LS01E-50	13U2430AB15	13.70	12.30	29,000	0.767
			CA243615	14.00	12.50	29,400	0.739
			13U3030AB15	14.00	12.50	29,400	0.739
			CA303615 ¹	14.50	13.00	30,400	0.746
			13U3036AB17	14.50	13.00	30,400	0.746
	AC14361G2	LS03E-30 LS03E-50	13U2430AB15	13.40	11.95	33,800	0.739
			CA243615	13.70	12.20	34,600	0.740
			13U3030AB15	13.70	12.20	34,600	0.740
			CA303615 ¹	14.00	12.50	35,600	0.750
			13U3036AB17	14.00	12.50	35,600	0.750
	AC14421G2	LS03E-30 LS03E-50	CA424215	13.40	12.00	41,000	0.748
			13U3642AB17	13.40	12.00	41,000	0.748
			CA424820 ²	13.80	12.20	42,000	0.749
			13U4248AB20 ²	13.80	12.20	42,000	0.749
			13C4860HA26 ²	14.10	12.50	43,000	0.758

¹adapter angles included with coil cabinet

² adaption required

SEE NEXT PAGE FOR MORE DATA -

FURNACE MODEL	CONDENSER MODEL	LINE SET MODEL	EVAPORATOR COIL MODEL	SEER	EER	TOTAL (BTU/HR) HEAT REMOVAL	SENSIBLE HEAT REMOVAL
CHB1-100	AC14301G2	LS01E-30 LS01E-50	13U2430AB15	13.70	12.30	29,000	0.767
			CA243619	14.00	12.50	29,400	0.739
			13U3030AB15	14.00	12.50	29,400	0.739
			CA303619	14.50	13.00	30,400	0.746
			13U3036AB17	14.50	13.00	30,400	0.746
	AC14361G2	LS03E-30 LS03E-50	13U2430AB15	13.40	11.95	33,800	0.739
			CA243619	13.70	12.20	34,600	0.740
			13U3030AB15	13.70	12.20	34,600	0.740
			CA303619	14.00	12.50	35,600	0.750
			13U3036AB17	14.00	12.50	35,600	0.750
	AC14421G2	LS03E-30 LS03E-50	CA424219	13.40	12.00	41,000	0.748
			13U3642AB17	13.40	12.00	41,000	0.748
			CA424820 ¹	13.80	12.20	42,000	0.749
			13U4248AB20	13.80	12.20	42,000	0.749
			13C4860HA26 ²	14.10	12.50	43,000	0.758
	AC14481G2	LS03E-30 LS03E-50	CA424219	13.00	11.60	46,000	0.746
			13U3642AB17	13.00	11.60	46,000	0.746
			CA424820 ¹	13.35	12.00	47,500	0.748
			13U4248AB20	13.35	12.00	47,500	0.748
			13C4860HA26 ²	13.65	12.20	48,500	0.758

¹adapter angles included with coil cabinet

² adaption required

FURNACE MODEL	CONDENSER MODEL	LINE SET MODEL	EVAPORATOR COIL MODEL	SEER	EER	TOTAL (BTU/HR) HEAT REMOVAL	SENSIBLE HEAT REMOVAL
CHB1-125	AC14421G2	LS03E-30 LS03E-50	13C3642AA23	13.40	12.00	41,000	0.748
			13U3642AB17	13.40	12.00	41,000	0.748
			13C4248HA23	13.80	12.20	42,000	0.749
			13U4248AB20	13.80	12.20	42,000	0.749
			13C4860HA26 ¹	14.10	12.50	43,000	0.758
	AC14481G2	LS03E-30 LS03E-50	13C3642AA23	13.00	11.60	46,000	0.746
			13U3642AB17	13.00	11.60	46,000	0.746
			13C4248HA23	13.35	12.00	47,500	0.748
			13U4248AB20	13.35	12.00	47,500	0.748
			13C4860HA26 ¹	13.65	12.20	48,500	0.758
	AC14601G2	LS03E-30 LS03E-50	13C4860HA26 ¹	13.00	11.60	60,000	0.753

¹Needs plenum adapter AOPS7693