



GAS HIGH EFFICIENCY COUNTERFLOW / HORIZONTAL FURNACE SPECIFICATIONS

MODEL NO.	CDB1-50N	CDB1-75N	CDB1-100N	CDB1-125N
FUEL	GAS NAT/LP	GAS NAT/LP	GAS NAT/LP	GAS NAT/LP
INPUT BTUH	50,000	75,000	100,000	125,000
OUTPUT BTUH ¹	47,000	70,000	94,000	116,000
SEASONAL EFFICIENCY ²	93.0%	93.0%	93.0%	92.0%
LARGEST REC A/C ³	2 T	3.5 T	4 T	5 T
NOMINAL TEMP RISE	70°	70°	70°	70°
APPROX EFFECTIVE HEATING SURFACE	5400 SQ IN.	5950 SQ IN	6500 SQ IN	7025 SQ IN
APPROX SHIPPING WEIGHT	195 LBS	210 LBS	235 LBS	253 LBS
APPROVAL AGENCY	CSA	CSA	CSA	CSA
DIA OF FLUE (PVC)	2"	2"	3"	3"
DIA OF COMBUSTION AIRINTAKE (PVC)	2"	2"	3"	3"
QTY AND SIZE OF PERMANENT FILTERS	TWO 1" x 22" x 14"	TWO 1" x 22" x 14"	TWO 1" x 22" x 14"	TWO 1" x 22" x 14"
ELECTRICAL RATING	115V 60HZ 1PH	115V 60HZ 1PH	115V 60HZ 1PH	115V 60HZ 1PH
MAX FUSE SIZE	15 AMP	15 AMP	15 AMP	20 AMP
ACCESSORY ITEMS				
COMBUSTIBLE FLOOR BASE	50DA-BASE	50DA-BASE	100CA-BASE	125CA-BASE
PROGRAMMABLE T-STAT STD/DELUXE	350164 / 350165	350164 / 350165	350164 / 350165	350164 / 350165
CONCENTRIC VENT KIT	AOPS7488	AOPS7488	AOPS7489	AOPS7489
SIDEWALL VENT CAP	370191	370191	370191	370191
NEUTRALIZER KIT	320095	320095	320095	320095
CONDENSATE PUMP	350225	350225	350225	350225
NAT. CONVERSION KIT	AOPS7665	AOPS7665	AOPS7665	AOPS7665
LP CONVERSION KIT	AOPS7677	AOPS7678	AOPS7679	AOPS7664
FURNACE PARTS KIT	AOPS7429	AOPS7429	AOPS7429	AOPS7429

¹ OUTPUT BTUH BASED ON ANNUAL FUEL UTILIZATION EFFICIENCY RATED BY MANUFACTURER.

² SEASONAL EFFICIENCY (ALSO CALLED AFUE - ANNUAL FUEL UTILIZATION EFFICIENCY) RATINGS ARE BASED ON TESTS FOLLOWING U.S. DEPARTMENT OF ENERGY TEST PROCEDURES.

³ TO PERMIT LARGEST RECOMMENDED AIR CONDITIONING (AT .5 STATIC PRESSURE), SELECTION OF THE HIGHEST MOTOR SPEED IS REQUIRED.

ALL SPECIFICATIONS ARE SUBJECT TO CHANGE WITHOUT NOTICE.

FURNACE NOMENCLATURE					
C	H	B	1	-50	N
C = CONDENSING	H = HIGHBOY (UPFLOW) D = COUNTERFLOW / HORIZONTAL	A = SERIES B = SERIES X = 2 STAGE, ECM	REVISION LEVEL	INPUT 50,000	NATURAL GAS

SEE NEXT PAGE FOR MORE DATA -

GAS HIGH-EFFICIENCY COUNTERFLOW / HORIZONTAL FURNACE SPECIFICATIONS

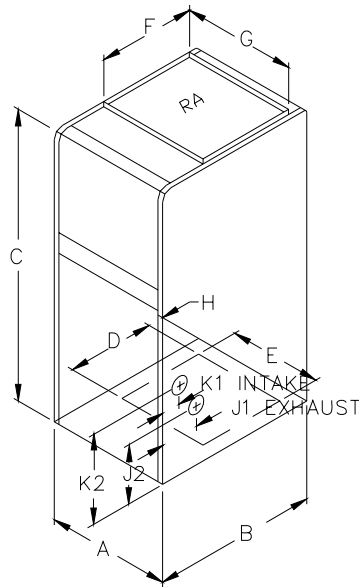

DIM / MODEL		CDB1-50N	CDB1-75N	CDB 1-100N	CDB1-125N
A		17"	17"	21"	24"
B		27-1/2"	27-1/2"	27-1/2"	27-1/2"
C		46-1/4"	46-1/4"	46-1/4"	46-1/4"
D		18"	18"	18"	18"
E		15"	15"	19"	22"
F		18"	18"	18"	18"
G		15"	15"	19"	22"
H		1"	1"	1"	1"
J1	L	6-1/2"	6-1/2"	6-1/2"	6-1/2"
	R	2-7/8"	2-7/8"	2-7/8"	2-7/8"
J2	L	14-3/4"	14-3/4"	14-3/4"	14-3/4"
	R	14-7/8"	14-7/8"	14-7/8"	14-7/8"
K1	L	2-7/8"	2-7/8"	2-7/8"	2-7/8"
	R	6-1/2"	6-1/2"	6-1/2"	6-1/2"
K2	L	16-1/2"	16-1/2"	16-1/2"	16-1/2"
	R	17-7/8"	17-7/8"	17-7/8"	17-7/8"

COMBUSTIBLE FLOOR BASE

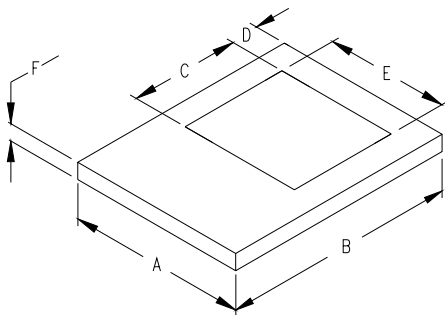

MODEL	50DA-BASE	100CA-BASE	125CA-BASE
DIM - A	17-1/4"	21-1/4"	24-1/4"
DIM - B	27-5/8"	27-5/8"	27-5/8"
DIM - C	18"	18"	18"
DIM - D	1"	1"	1"
DIM - E	15"	19"	22"
DIM - F	2"	2"	2"

SEE NEXT PAGE FOR MORE DATA -

GAS HIGH-EFFICIENCY COUNTERFLOW / HORIZONTAL FURNACE SPECIFICATIONS

BLOWER DATA:	CDB1-50N	CDB1-75N	CDB1-100N	CDB1-125N
BLOWER MODEL ¹	10-9R DD	10-9R DD	10-10R DD	12-11T DD
MOTOR H.P.	1/5 - 3SP	1/3 - 4SP	1/2 - 4SP	3/4 - 4SP

BURNER DATA:				
BURNER TYPE	INSHOT	INSHOT	INSHOT	INSHOT
NO. PER UNIT	2	3	4	5
MAX INLET PRESSURE (NAT)	14" WC	14" WC	14" WC	14" WC
MIN INLET PRESSURE (NAT)	4.5" WC	4.5" WC	4.5" WC	4.5" WC
MAX INLET PRESSURE (LP)	14" WC	14" WC	14" WC	14" WC
MIN INLET PRESSURE (LP)	11" WC	11" WC	11" WC	11" WC
NORMAL MANIFOLD PRESS (NAT)	3.5" WC	3.5" WC	3.5" WC	3.5" WC
NORMAL MANIFOLD PRESS (LP)	10" WC	10" WC	10" WC	10" WC
ORIFICE SIZE (NAT.)	0.0935" (#42)	0.0935" (#42)	0.0935" (#42)	0.0935" (#42)
DIA. (D.M.S.) (L.P.)	0.0591" (1.5mm)	0.0591" (1.5mm)	0.0591" (1.5mm)	0.0591" (1.5mm)

CLEARANCES:				
MINIMUM CLEARANCES TO COMBUSTIBLE MATERIALS:				
SIDES	0"	0"	0"	0"
FRONT (SERVICE ACCESS)	6" (24")	6" (24")	6" (24")	6" (24")
BACK	0"	0"	0"	0"
FLUE PIPE	0"	0"	0"	0"
TOP	1	1	1	1

¹ DD = DIRECT DRIVE

GAS HIGH-EFFICIENCY COUNTERFLOW / HORIZONTAL FURNACE SPECIFICATIONS CDB1-50N

ALTERATIONS REQ'D FOR A/C @ DESIGN EXTERNAL STATIC PRESSURE		
COOLING UNIT	HTG Speed	Recommended CLG Speed
24,000	LOW	HIGH

Speed Tap \ Static Pressure	Furnace Airflow (CFM) vs. External Static pressure (in. WC.)						
	0.1	0.2	0.3	0.4	0.5	0.6	0.7
Low	695	605	529	458	397	314	246
Med	1034	1000	936	833	760	676	611
High	1182	1132	1065	952	868	782	670

Speed Tap \ Static Pressure	Temperature Rise vs. External Static Pressure (in. WC.)						
	0.1	0.2	0.3	0.4	0.5	0.6	0.7
Low	62	71	81	94	108	137	175
Med	42	43	46	52	57	64	71
High	36	38	40	45	50	55	64

Speed Tap \ Static Pressure	Blower Motor Current Draw (Amps) vs. External Static pressure (in. WC.)						
	0.1	0.2	0.3	0.4	0.5	0.6	0.7
Low	1.5	1.4	1.4	1.3	1.3	1.2	1.2
Med	2.8	2.7	2.6	2.5	2.3	2.2	2.2
High	3.3	3.2	3.0	2.8	2.7	2.6	2.4

Speed Tap \ Static Pressure	Blower Motor Watts vs. External Static pressure (in. WC.)						
	0.1	0.2	0.3	0.4	0.5	0.6	0.7
Low	165	159	154	149	145	138	133
Med	304	297	287	274	264	252	245
High	375	355	335	319	302	290	274

= Recommended operation range

SEE NEXT PAGE FOR MORE DATA -

GAS HIGH-EFFICIENCY COUNTERFLOW / HORIZONTAL FURNACE SPECIFICATIONS CDB1-75N

ALTERATIONS REQ'D FOR A/C @ DESIGN EXTERNAL STATIC PRESSURE		
COOLING UNIT	HTG Speed	Recommended CLG Speed
24,000	MED-LOW	MED-LOW
30,000	MED-LOW	MED-HIGH
36,000	MED-LOW	HIGH
42,000	MED-LOW	HIGH

Speed Tap \ Static Pressure	Furnace Airflow (CFM) vs. External Static pressure (in. WC.)						
	0.1	0.2	0.3	0.4	0.5	0.6	0.7
Low	738	721	675	652	611	558	488
ML	903	898	889	819	783	725	662
MH	1204	1207	1186	1150	1087	955	866
High	1590	1544	1492	1446	1371	1294	1057

Speed Tap \ Static Pressure	Temperature Rise vs. External Static Pressure (in. WC.)						
	0.1	0.2	0.3	0.4	0.5	0.6	0.7
Low	87	90	96	99	106	116	132
ML	72	72	73	79	82	89	98
MH	54	54	54	56	59	68	75
High	40	41	43	44	47	49	60

Speed Tap \ Static Pressure	Blower Motor Current Draw (Amps) vs. External Static pressure (in. WC.)						
	0.1	0.2	0.3	0.4	0.5	0.6	0.7
Low	2.7	2.6	2.5	2.4	2.3	2.2	2.0
ML	3.5	3.3	3.2	2.9	2.8	2.7	2.5
MH	4.6	4.3	4.1	3.9	3.6	3.3	3.1
High	5.8	5.5	5.2	5.1	4.7	4.5	3.9

Speed Tap \ Static Pressure	Blower Motor Watts vs. External Static pressure (in. WC.)						
	0.1	0.2	0.3	0.4	0.5	0.6	0.7
Low	266	259	250	247	241	230	217
ML	349	336	326	308	299	285	273
MH	479	459	443	423	394	365	342
High	634	605	577	558	522	497	436

= Recommended operation range

GAS HIGH-EFFICIENCY COUNTERFLOW / HORIZONTAL FURNACE SPECIFICATIONS CDB1-100N

ALTERATIONS REQ'D FOR A/C @ DESIGN EXTERNAL STATIC PRESSURE		
COOLING UNIT	HTG Speed	Recommended CLG Speed
24,000	LOW	LOW
30,000	LOW	LOW
36,000	LOW	MED-LOW
42,000	LOW	MED-HIGH
48,000	LOW	HIGH

Speed Tap \ Static Pressure	Furnace Airflow (CFM) vs. External Static pressure (in. WC.)						
	0.1	0.2	0.3	0.4	0.5	0.6	0.7
Low	1310	1300	1274	1223	1155	999	911
ML	1500	1462	1400	1335	1252	1123	986
MH	1662	1593	1543	1465	1389	1271	1109
High	1886	1810	1707	1639	1548	1438	1320

Speed Tap \ Static Pressure	Temperature Rise vs. External Static Pressure (in. WC.)						
	0.1	0.2	0.3	0.4	0.5	0.6	0.7
Low	66	66	68	70	75	86	94
ML	57	59	62	64	69	77	87
MH	52	54	56	59	62	68	78
High	46	48	50	53	56	60	65

Speed Tap \ Static Pressure	Blower Motor Current Draw (Amps) vs. External Static pressure (in. WC.)						
	0.1	0.2	0.3	0.4	0.5	0.6	0.7
Low	5.4	5.2	5.0	4.7	0.3	3.9	3.7
ML	5.9	5.7	5.3	5.0	4.8	4.2	3.9
MH	6.6	6.2	5.9	5.6	5.3	4.9	4.5
High	8.3	8.0	7.7	7.5	7.3	7.0	6.8

Speed Tap \ Static Pressure	Blower Motor Watts vs. External Static pressure (in. WC.)						
	0.1	0.2	0.3	0.4	0.5	0.6	0.7
Low	621	599	576	544	498	450	426
ML	683	651	611	573	549	486	450
MH	759	714	680	643	604	560	519
High	949	922	889	864	834	807	779

= Recommended operation range

SEE NEXT PAGE FOR MORE DATA -

GAS HIGH-EFFICIENCY COUNTERFLOW / HORIZONTAL FURNACE SPECIFICATIONS CDB1-125N

ALTERATIONS REQ'D FOR A/C @ DESIGN EXTERNAL STATIC PRESSURE		
COOLING UNIT	HTG Speed	Recommended CLG Speed
24,000	LOW	-
30,000	LOW	-
36,000	LOW	LOW
42,000	LOW	MED-LOW
48,000	LOW	MED-HIGH
60,000	LOW	HIGH

Speed Tap \ Static Pressure	Furnace Airflow (CFM) vs. External Static pressure (in. WC.)						
	0.1	0.2	0.3	0.4	0.5	0.6	0.7
Low	1661	1648	1622	1591	1559	1502	1449
ML	1748	1718	1683	1647	1604	1563	1502
MH	1819	1781	1752	1728	1688	1642	1605
High	2380	2342	2304	2233	2150	2069	1984

Speed Tap \ Static Pressure	Temperature Rise vs. External Static Pressure (in. WC.)						
	0.1	0.2	0.3	0.4	0.5	0.6	0.7
Low	64	65	66	67	68	71	74
ML	61	62	63	65	66	68	71
MH	59	60	61	62	64	66	67
High	45	45	46	48	50	51	54

Speed Tap \ Static Pressure	Blower Motor Current Draw (Amps) vs. External Static pressure (in. WC.)						
	0.1	0.2	0.3	0.4	0.5	0.6	0.7
Low	7.4	7.3	7.1	6.8	6.6	6.3	6.1
ML	7.9	7.6	7.4	7.1	6.9	6.8	6.4
MH	8.4	8.3	8.0	7.8	7.6	7.2	7.0
High	11.2	10.9	10.6	10.2	9.8	9.4	9.0

Speed Tap \ Static Pressure	Blower Motor Watts vs. External Static pressure (in. WC.)						
	0.1	0.2	0.3	0.4	0.5	0.6	0.7
Low	748	735	723	705	690	665	641
ML	800	781	764	743	722	705	677
MH	857	845	829	808	791	761	742
High	1190	1160	1130	1100	1050	1000	968

= Recommended operation range

SEE NEXT PAGE FOR MORE DATA -

GAS HIGH EFFICIENCY COUNTERFLOW / HORIZONTAL FURNACE SPECIFICATIONS
EVAPORATOR COIL APPLICATION

FURNACE MODEL	CONDENSER MODEL	LINE SET MODEL	COIL CABINET MODEL	EVAPORATOR COIL MODEL	SEER	EER	TOTAL (BTU/HR) HEAT REMOVAL	SENSIBLE HEAT REMOVAL
CDB1-50N COUNTERFLOW	AC14241G2	LS01E-30	CE105S	13U2430AB15	13.80	12.30	24,000	0.730
		LS01E-50	CE205T	13U3036AB17	14.40	12.70	25,400	0.739
CDB1-50N HORIZONTAL	AC14241G2	LS01E-30	N/A	13C2430HA17	14.00	12.40	24,000	0.733
		LS01E-50		13C3036HA17	14.40	12.70	25,400	0.739

FURNACE MODEL	CONDENSER MODEL	LINE SET MODEL	COIL CABINET MODEL	EVAPORATOR COIL MODEL	SEER	EER	TOTAL (BTU/HR) HEAT REMOVAL	SENSIBLE HEAT REMOVAL
CDB1-75N COUNTERFLOW	AC14241G2	LS01E-30	CE105S	13U2430AB15	13.80	12.30	24,000	0.730
		LS01E-50	CE205T	13U3036AB17	14.40	12.70	25,400	0.739
	AC14301G2	LS01E-30	CE105S	13U2430AB15	13.70	12.30	29,000	0.737
		LS01E-50	CE205T	13U3036AB17	14.50	13.00	30,400	0.746
	AC14361G2	LS03E-30	CE105S	13U2430AB15	13.40	11.95	33,800	0.736
		LS03E-50	CE205T	13U3036AB17	14.00	12.50	35,600	0.750
	AC14421G2	LS03E-30	CE205T	13U3642AB17	13.40	12.00	41,000	0.748
			LS03E-50					
CDB1-75N HORIZONTAL	AC14241G2	LS01E-30	N/A	13C2430HA17	14.00	12.40	24,000	0.733
		LS01E-50		13C3036HA17	14.40	12.70	25,400	0.739
	AC14301G2	LS01E-30	N/A	13C2430HA17	14.00	12.50	29,400	0.739
		LS01E-50		13C3036HA17	14.50	13.00	30,400	0.746
	AC14361G2	LS03E-30	N/A	13C2430HA17	13.70	12.20	34,600	0.740
		LS03E-50		13C3036HA17	14.00	12.50	35,600	0.750
	AC14421G2	LS03E-30	N/A	13C3642HA17	13.40	12.00	41,000	0.748
		LS03E-50						

FURNACE MODEL	CONDENSER MODEL	LINE SET MODEL	COIL CABINET MODEL	EVAPORATOR COIL MODEL	SEER	EER	TOTAL (BTU/HR) HEAT REMOVAL	SENSIBLE HEAT REMOVAL
CDB1-100N COUNTERFLOW	AC14361G2	LS03E-30	CE107S	13U2430AB15	13.40	11.95	33,800	0.736
		LS03E-50	CE206TA	13U3036AB17	14.00	12.50	35,600	0.750
	AC14421G2	LS03E-30	CE206TA	13U3642AB17	13.40	12.00	41,000	0.748
		LS03E-50						
CDB1-100N HORIZONTAL	AC14361G2	LS03E-30	N/A	13C2430HA21	13.70	12.20	34,600	0.740
		LS03E-50		13C3036HA21	14.00	12.50	35,600	0.750
	AC14421G2	LS03E-30 LS03E-50	N/A	13C3642HA21	13.40	12.00	41,000	0.748
				13C4248HA21	13.80	12.20	42,000	0.749
				13C4860HA26 ²	14.10	12.50	43,000	0.758
	AC14481G2	LS03E-30 LS03E-50	N/A	13C3642HA21	13.00	11.60	46,000	0.746
				13C4248HA21	13.35	12.00	47,500	0.748
				13C4860HA26 ²	13.65	12.20	48,500	0.758

² adaption required

SEE NEXT PAGE FOR MORE DATA -

GAS HIGH EFFICIENCY COUNTERFLOW / HORIZONTAL FURNACE SPECIFICATIONS
EVAPORATOR COIL APPLICATION

FURNACE MODEL	CONDENSER MODEL	LINE SET MODEL	COIL CABINET MODEL	EVAPORATOR COIL MODEL	SEER	EER	TOTAL (BTU/HR) HEAT REMOVAL	SENSIBLE HEAT REMOVAL
CDB1-125N COUNTERFLOW	AC14421G2	LS03E-30 LS03E-50	CE208TA	13U3642AB17	13.40	12.00	41,000	0.748
	AC14481G2	LS03E-30 LS03E-50	CE208TA	13U3642AB17	13.00	11.60	46,000	0.746
	AC14601G2	LS03E-30 LS03E-50						
CDB1-125N HORIZONTAL	AC14421G2	LS03E-30 LS03E-50	N/A	13C3642HA23	13.40	12.00	41,000	0.748
				13C4248HA23	13.80	12.20	42,000	0.749
				13C4860HA26 ¹	14.10	12.50	43,000	0.758
	AC14481G2	LS03E-30 LS03E-50	N/A	13C3642HA23	13.00	11.60	46,000	0.746
				13C4248HA23	13.35	12.00	47,500	0.748
				13C4860HA26	13.65	12.20	48,500	0.758
AC14601G2	LS03E-30 LS03E-50	N/A	13C4860HA26 ¹	13.00	11.60	60,000	0.753	

¹Needs plenum adapter AOPS7693