

Thermo Pride®

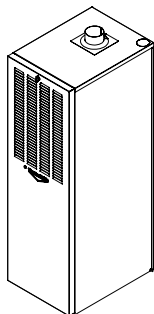

OIL-FIRED FURNACE DOWN FLOW & DIRECT VENT (SEALED COMBUSTION)



MODEL: OME-72D36 INSTALLATION AND SERVICE MANUAL

For installation in:

1. Manufactured Homes
2. Modular Homes/Buildings
3. Site Construction—Residential

⚠WARNING:

FOR YOUR SAFETY

Do not store or use gasoline or other flammable vapors and liquids in the vicinity of this or any other appliance.

WHAT TO DO IF YOU SMELL GAS

- Do not try to light any appliance.
- Do not touch any electrical switch; do not use any phone in your building.
- Immediately call your gas supplier from a neighbor's phone.
Follow the gas supplier's instructions.
- If you cannot reach your gas supplier, call the fire department.

⚠WARNING: *If the information in these instructions is not followed exactly, a fire or explosion may result causing property damage, personal injury or loss of life.*

⚠WARNING: *Improper installation, adjustment, alteration, service, or maintenance can cause injury or property damage. Refer to this manual. For assistance or additional information consult a qualified installer, service agency, or fuel supplier.*

⚠WARNING: *Do not use this appliance if any part has been underwater. Immediately call a qualified service technician to inspect the appliance and to replace any part of the electrical or control system that has been underwater.*

PLEASE READ THESE INSTRUCTIONS PRIOR TO INSTALLATION, INITIAL FIRING, AND BEFORE PERFORMING ANY SERVICE OR MAINTENANCE. THESE INSTRUCTIONS MUST BE LEFT WITH THE USER AND SHOULD BE RETAINED FOR FUTURE REFERENCE BY QUALIFIED SERVICE PERSONNEL.



THERMO PRODUCTS, LLC.
POST OFFICE BOX 217
NORTH JUDSON, IN 46366
PHONE: (574) 896-2133



MO-487
ECN 5201-MA 110920

MADE IN USA

All installations and services must be performed by qualified service personnel.

I. SAFETY SECTION

This page and the following two pages contain various warnings and cautions found throughout this furnace Service and Installation Manual. Please read and comply with the statements on the cover and the statements below.

⚠WARNING: *All local codes and ordinances must be followed with regard to the oil tank and oil lines. All lines must have shut off valves, use a proper pipe joint compound (specified for use with oil) on all pipe threads, no kinks, no sharp bends, and be properly tested for leaks. Flare fittings are recommended for tubing.*

⚠WARNING: *This furnace is not to be used as a construction heater.*

⚠WARNING: *DO NOT RUN THE OIL PUMP DRY FOR MORE THAN FIVE MINUTES.*

⚠WARNING: *When testing electrical equipment, always follow standard electrical procedures and precautions.*

⚠WARNING: *The heat exchanger must be cleaned by a qualified service person.*

⚠WARNING: *The area around the furnace should be kept free and clear of combustible materials, especially papers and rags.*

⚠WARNING: *NEVER burn garbage or refuse in your furnace. NEVER try to ignite oil or gas by tossing burning papers or other material into your furnace.*

⚠WARNING: *Thermo Pride oil furnaces are designed to burn commercial standards of No. 1 and No. 2 fuel oil. NEVER USE GASOLINE OR A MIXTURE OF OIL AND GASOLINE.*

⚠WARNING: *Do not attempt to start the burner when: 1. Excess oil has accumulated 2. The furnace is full of vapors or 3. The combustion chamber is very hot. If one or more of these conditions exist, contact a qualified service person.*

⚠CAUTION: *If the temperature rise exceeds 100°F, the heat exchanger may fail voiding the heat exchanger warranty resulting in property damage, personal injury or loss of life.*

⚠WARNING: *Burner adjustments must be confirmed by instrumentation. Failure to use accurate or calibrated instrumentation to setup the burner may result in reduced efficiency, sooting and/or the production of hazardous carbon monoxide gas.*

⚠WARNING: *Any attempt to relocate safety controls or replace safety controls with a control that is not approved or incompatible, may result in personal injury, substantial property damage or death.*

All installations and services must be performed by qualified service personnel.

⚠WARNING: *If you do not follow these instructions exactly, a fire or explosion may result causing personal injury, loss of life or property damage.*

⚠WARNING: *NEVER use gasoline or a mixture of oil and gasoline to start the burner or furnace.*

⚠WARNING: HAZARD OF ASPHYXIATION: *Negative pressure inside the closet with closet door closed and the furnace blower operating shall be no more negative than minus 0.05 inch water column.*

⚠WARNING: *Do not obstruct any return air openings, including the return grille on the furnace. To do so may cause the furnace to activate the high limit and shut down or it may cause asphyxiation.*

⚠WARNING: *Because of the potential of odorant fade, a gas leak may not be detected by smell. If this furnace is installed below grade, contact your gas supplier for a gas detector.*

⚠WARNING: *All gas pipe connections must be leak tested using a strong soap and water solution (with the gas turned on). Any leaks must be repaired immediately after turning off the gas supply. A final test for gas leakage must be made after purging the gas line.*

⚠CAUTION: *DO NOT wet electronic components during the leak test. Wetting electronic components may damage circuitry and cause a hazardous situation. Dry moisture from all leads and terminals if wetting occurs. Wait at least 24 hours for the circuit to fully dry before energizing the system.*

⚠WARNING: *The furnace and its gas valve must be disconnected from the gas supply during pressure testing of the gas supply system at pressures in excess of 1/2 PSIG or 13.9 inches W.G. The furnace can be isolated from the gas supply by closing its manual shut off valve at test pressures equal to or less than 1/2 PSIG or 13.9 inches W.G.*

⚠WARNING: *Copper and brass tubing and fittings (except tin lined) shall not be used if the gas contains more than a trace (0.3 grains per 100 cubic ft.) of hydrogen sulfide gas. Check with your gas supplier.*

⚠WARNING: *All local codes and ordinances take precedence with regard to tank and oil lines. All lines must have shutoff valves, a good pipe joint compound approved for use with oil on all pipe threads, no kinks, no sharp bends and be properly tested for leaks. Flare fittings are recommended for tubing.*

⚠CAUTION: *Do not use motor oil or any fuel heavier than No. 2 fuel oil..*

All installations and services must be performed by qualified service personnel.

⚠WARNING: *If you suspect there is a problem with the furnace, the venting system or any other related problem, immediately contact a qualified service agency. If a service agency is not available contact your fuel supplier.*

⚠WARNING: *Personal injury, or property damage, could result from major repair or service of this furnace by anyone other than a qualified contractor. Only the routine maintenance described in the user section of this manual should be performed by the user.*

⚠WARNING: *The area around the furnace should be kept free and clear of combustible materials, especially papers and rags.*

⚠WARNING: *Never burn garbage or refuse in your furnace. Never try to ignite oil or gas by tossing burning papers or other material into your furnace.*

⚠CAUTION: *Do not attempt to start the burner when:*

- 1. Excess oil or gas has accumulated.*
- 2. The furnace is full of vapors.*
- 4. The combustion chamber is very hot.*

If one or more of these conditions exist, contact a qualified service person.

⚠CAUTION: *Do not block or obstruct air openings on the furnace or air openings communicating with the area in which the furnace is installed.*

⚠CAUTION: *Do not allow the outside air intake to be blocked or obstructed by vegetation, ice, snow or any other materials.*

⚠WARNING: *Do not use this furnace if any part has been underwater. Immediately call a qualified service agency to inspect the furnace and to replace any part of the electrical or control system which has been underwater.*

⚠WARNING: *Should overheating occur or the fuel supply fail to shut off, shut off the manual fuel supply valve to the furnace before shutting off the electrical supply.*

All installations and services must be performed by qualified service personnel.

This page and the following page contain reproductions of the various warning and instruction labels placed on the Thermo Pride Oil Furnace. Please read and comply with the contents of these labels.

⚠ WARNING

SPECIAL HOMEOWNERS INSTRUCTIONS

- **IMPROPER INSTALLATION, ADJUSTMENT, ALTERATION, SERVICE OR MAINTENANCE CAN CAUSE PROPERTY DAMAGE, PERSONAL INJURY OR LOSS OF LIFE.**
- **FOR SAFE OPERATION** IT IS THE RESPONSIBILITY OF THE OWNER AND/OR USER THAT THE BURNER, CHIMNEY/VENT PIPE, HEAT EXCHANGER AND CONTROLS SHOULD BE INSPECTED EVERY YEAR BY A QUALIFIED HEATING CONTRACTOR.
- THE OWNER AND/OR USER SHOULD ALSO CONDUCT PERIODIC VISUAL INSPECTIONS. REFER TO THE USERS INFORMATION SECTION IN THE MANUAL PROVIDED WITH THIS FURNACE FOR DETAILS.
- ANY DEFICIENCIES NOTED MUST BE CORRECTED AT ONCE BY A QUALIFIED HEATING CONTRACTOR. DO NOT ATTEMPT TO MAKE REPAIRS YOURSELF!
- FOR ASSISTANCE OR ADDITIONAL INFORMATION CONSULT A QUALIFIED INSTALLER, SERVICE AGENCY OR THE GAS/OIL SUPPLIER.

CAUTION

**MOVING PARTS.
CAN CAUSE SEVERE PERSONAL INJURY**

SHUT OFF FURNACE BEFORE REMOVING THIS PANEL.

FOR YOUR SAFETY

DO NOT STORE GASOLINE OR OTHER FLAMMABLE VAPORS AND LIQUIDS IN THE VICINITY OF THIS OR ANY OTHER APPLIANCE.

THIS UNIT MUST BE INSTALLED AND SERVICED BY A QUALIFIED CONTRACTOR ONLY.

FILTER MAINTENANCE: WHEN IT BECOMES NECESSARY TO REPLACE OR WASH FILTER REMOVE THE DIRTY FILTER FROM THE RACKS PROVIDED AND WASH OR REPLACE WITH IDENTICAL NEW FILTERS.

DO NOT REMOVE THIS LABEL

390437

⚠ WARNING

REINSTALL ALL PARTS!

Should this unit be disassembled all components, panels, block offs, collars, gaskets, and fasteners must be reassembled as originally factory produced.

Failure to do so may result in property damage, injury, or loss of life.

390056

⚠ WARNING

This compartment must be closed except when servicing.

390024

CAUTION SHOULD BE USED IN CLEANING AND SERVICING FURNACE TO AVOID DAMAGING COMBUSTION CHAMBER LINER.

390450

WARNING – TO REDUCE THE RISK OF FIRE, DO NOT STORE OR USE GASOLINE OR OTHER FLAMMABLE VAPORS AND LIQUIDS IN THE VICINITY OF THE FURNACE.

390448

FOR LIGHTING, OPERATING AND SHUTDOWN INSTRUCTIONS, REFER TO THE MOBILE HOME FURNACE MANUAL.

KEEP CLOSED WHEN
APPLIANCE IS IN OPERATION

390400

⚠ WARNING

HAZARDOUS VOLTAGE

Avoid contact with exposed live voltage terminals. Do not bypass or disconnect limit. Turn off power prior to service.

Failure to do so may result in property damage, injury, or loss of life.

390526

⚠ CAUTION

RESEAL HEAT EXCHANGER ACCESS PORTS

Clean outs accessible by qualified service personnel only. Access to clean out may require removal of panel. Be certain clean out covers and/or gaskets are intact and in proper position to ensure complete seal prior to operation.

Failure to do so may result in property or equipment damage.

390528

⚠ CAUTION

ROTATING FAN BLADE!

To avoid injury from hot or moving parts, shut off the furnace and allow to cool before removing this door.

When it becomes necessary to replace or wash filter, remove the dirty filter from the racks provided and wash or replace with identical new filters.

The blower motor located behind this door may or may not require lubrication. If lubrication instructions are not shown on the motor nameplate, the motor should not be lubricated. If the nameplate indicates that the motor requires lubrication, lubricate the motor as directed or use 30 drops of SAE 20 weight oil or equivalent twice a year. Do not use a light household grade oil.

390025

All installations and services must be performed by qualified service personnel.

TABLE OF CONTENTS

<u>SECTION</u>	<u>BEGINNING PAGE</u>
I. SAFETY SECTION	1
II. GENERAL INSTRUCTIONS AND CLEARANCES	6
III. FURNACE SPECIFICATIONS	8
IV. INSTALLATION	10
A. ROOF JACK	10
B. STANDARD CHIMNEY	10
C. FURNACE LOCATION	10
D. BASE INSTALLATION	11
1. Combustible Floor Base Model: 70-BASE	11
2. Cottage Base Model: OMCCOT-BASE	13
E. ALCOVE INSTALLATION	15
F. CLOSET INSTALLATION	15
G. COMBUSTION AIR	16
H. FUEL PIPING	19
1. Oil Tank and Piping	19
J. ELECTRICAL WIRING	21
1. Electrical Branch Supply Circuit	22
2. Connection of Power Supply Wires	22
3. Connection of Thermostat Wires	22
4. Blower Controller Information for PSC Motor	23
5. Wiring Diagram	28
K. BURNER INSTALLATION	29
L. BURNER OPERATION AND ADJUSTMENT	29
M. FLUE GAS COMBUSTION ANALYSIS	32
V. DEALER MAINTENANCE	33
A. TROUBLESHOOTING	34
B. CAD CELL CHECKOUT PROCEDURE	39
C. HEAT EXCHANGER CLEANING INSTRUCTIONS	39
D. CLEANING OR REPLACING FLUE PIPES	41
E. EXTENDED SHUTDOWN AND RESTART	41
VI. USERS INFORMATION SECTION	42
A. WARNINGS & CAUTIONS	42
B. COMPONENT LOCATIONS	43
C. INSPECTION AREAS	43
D. FILTER LOCATION AND CLEANING	44
E. CONTACT INFORMATION	44
APPENDIX A - REPLACEMENT PARTS LIST	45
WARRANTY	47

All installations and services must be performed by qualified service personnel.

II. GENERAL INSTRUCTIONS AND CLEARANCES

NOTE: READ THIS SECTION BEFORE STARTING INSTALLATION

1. The selection of a furnace heating capacity for a proposed installation should be based on a heat loss calculation made according to the manuals provided by the Air Conditioning Contractors of America (ACCA) or the American Society of Heating, Refrigeration and Air Conditioning Engineers, Inc. (ASHRAE).
2. The installer shall be familiar with and comply with all codes and regulations applicable to the installation of this heating appliance. In addition to the governing standards items a) through e) this appliance shall also comply with “CSA B139 for recommended installation practices” where applicable.
 - a. Federal Manufactured Home Constructions & Safety Standard (HUD Total 24, Part 280).
 - b. American National Standard (ANSI-119.2/NFPA-501C), for all recreational vehicle installations.
 - c. American National Standard (ANSI-Z223.1/NFPA-54), for all gas-fired furnaces.
 - d. American National Standard (ANSI-Z95.1/NFPA-31), for all oil-fired furnaces.
 - e. American National Standard Electric Code (ANSI-C1/NFPA-70), for all electrical field wiring.

The oil-fired furnace has been investigated under the UL 307A test standard and CSA B140 and is listed by ETL and described as, “For installation as central furnace special type”.

⚠WARNING: The area around the furnace must be kept free and clear of combustible materials, especially papers and rags.

⚠WARNING: This furnace is not to be used as a construction heater.

1. Definitions of "combustible" and "non-combustible" materials as presented in the 1996 version of the National Fuel Gas Code, ANSI Z223.1-1996/NFPA 70-1996, are as follows:
 - a. **Combustible material:**
“...materials made of or surfaced with wood, compressed paper, plant fibers, or other materials that are capable of being ignited and burned. Such materials shall be considered combustible even though flameproofed, fire-retardant treated, or plastered.”

- b. **Non-combustible material:**

All installations and services must be performed by qualified service personnel.

“...material that is not capable of being ignited and burned; such as material consisting entirely of, or a combination of, steel, iron, brick, concrete, slate, asbestos, glass, and plaster.”

This heating appliance must be installed with clearances to combustible material surfaces of not less than the minimum distances given below. Also, allow ample clearances for servicing the furnace for easy access to the air filter, blower assembly, burner assembly, controls, and vent connections.

MODELS OME	CLOSET	ALCOVE
FRONT	6”	18”
BACK	0”	0”
SIDES	0”	0”
ROOF JACK	0”	0”
VENT CONNECTOR	6”	6”
TOP	1”	1”
PLENUM SIDES	1”	1”
TOP AND SIDES OF DUCT	1”	1”
BOTTOM OF DUCT	1”	1”

All installations and services must be performed by qualified service personnel.

III. FURNACE SPECIFICATIONS

<u>MODEL</u>	<u>OME-72</u>	
	Low Fire	High Fire ¹
HEAT INPUT RATE (BTUH)	70,000	85,000
HEATING CAPACITY (BTUH)	60,000	72,000
BURNER NOZZLE (GPH X ANGLE, HOLLOW CONE)	0.50X80°A	0.60X80°A
OIL PUMP PRESSURE (PSIG)	120	
VENT PIPE SIZE (INCHES)	4	
DESIGN TEMPERATURE RISE (°F)	65	
MINIMUM RETURN AIR TEMP. (°F)	50	
SEASONAL EFFICIENCY (AFUE ² *, %)	86	

¹ Burner shipped with 0.60x80°A nozzle

²*AFUE - INCLUDES STEADY STATE THERMAL EFFICIENCY AND OFF CYCLE LOSSES.

ELECTRICAL RATINGS AND SETTINGS:

ELECTRICAL SUPPLY: 120 VAC / 60HZ / 1 PHASE

MAXIMUM TIME DELAY TYPE FUSE OR HACR BREAKER RATING: 15 AMPS

TOTAL RATED CURRENT (AMPS): 10.3

NOMINAL HEAT ANTICIPATOR SETTING -- 0.2 mA

DIMENSIONS & WEIGHTS:

CABINET: WIDTH - 18 IN., DEPTH - 24-3/4 IN., HEIGHT - 57 IN.

NO.70 MOBILE HOME BASE: WIDTH - 18 5/16 IN., DEPTH - 24¼ IN., HEIGHT - 4 IN.

WARM AIR DUCT: WIDTH - 12 IN., DEPTH - 12 IN., HEIGHT - 14 ¼ IN.

COTTAGE BASE: WIDTH - 18 3/16 IN., DEPTH - 24¼ IN., HEIGHT - 14¾ IN.

FILTER QUANTITY & SIZE: (1) @ 18 IN. x 24 IN. x 1 IN. EA.

APPROXIMATE SHIPPING WEIGHT: 240 LBS.

BURNER DATA

OME-72

MANUFACTURER: R.W. BECKETT CORP.

MODEL: AFG

AIR TUBE LENGTH (IN.): 3

HEAD DESIGN: F-3

REFRACTORY TYPE: ISOFORM (SOFT FIBER)

OIL PUMP

PRESSURE (P.S.I.G.) 120

All installations and services must be performed by qualified service personnel.

FOR BURNER COMBUSTION INFORMATION, REFER TO SECTION (M) – FLUE GAS COMBUSTION ANALYSIS.

BLOWER DATA

MANUFACTURER: MORRISON PRODUCTS, INC.

BLOWER MODEL: 12-9T, DIRECT DRIVE

NOMINAL MOTOR POWER OUTPUT (HORSEPOWER): 1/2 HP 4 SPEED

HIGH SPEED AIRFLOW (SCFM)

@ 0.5 IN. W.G. EXTERNAL

STATIC PRESSURES 1195

ALL SPECIFICATIONS ARE SUBJECT TO CHANGE WITHOUT NOTICE.

All installations and services must be performed by qualified service personnel.

IV. INSTALLATION

A. ROOF JACK

The roof jack assembly and accessories must be listed by a nationally recognized testing agency for the appropriate fuel.

The roof jack assembly must be installed according to the vent manufacturer's instructions prior to the furnace installation. (Refer to Figure 2 for flue location on furnace.) Adapters for pitched roofs as well as extended barrel length roof jacks are available from Thermo Products.

All vent seams and connections must be sealed with high temperature silicone caulk and/or high temperature aluminum tape.

B. STANDARD CHIMNEY

When installed as a central furnace special type for single story dwelling, venting into a metal vent system approved by a nationally recognized testing agency for the appropriate fuel type is permitted. Lined masonry chimneys are acceptable when sized appropriately. The minimum chimney size should be equivalent to the inside free area of the 4-inch diameter vent collar exiting the furnace, or 12.5 square inches.

Maximum chimney sizes and acceptable installation practices are referenced in the following publications. In lieu of local codes, when installing the OME-72 with fuel oil, refer to the latest edition of the installation standard NFPA 31, Installation of Oil Burning Equipment.

Notice: Blocked Vent Switch Installation for cottage type homes or non-mobile home type dwellings. The blocked vent switch kit must be installed to comply with CAN STD B140.4 where applicable. For installation instructions see AOPS2686 kit.

C. FURNACE LOCATION

1. For best performance, locate the furnace so that it is centralized with respect to the duct system.
2. This furnace is only intended for installation with free air return through the furnace door louvers. **DO NOT** connect a ducted return air system directly to the furnace. Improper installation may create a fire hazard and damage internal equipment, as well as void all manufacturer's warranties.
3. This furnace may be installed on combustible flooring when utilizing either the No. 70 counterflow floor base, for below the floor duct systems, or with the cottage base, for floor level air distribution. See Figures 1 for depictions of the No. 70 and the cottage bases.

All installations and services must be performed by qualified service personnel.

4. This furnace is ETL listed for closet, alcove or freestanding applications. All applications must comply with the requirements of this manual.

**Combustible Floor Base
Model: 70-BASE**

Figure 1A.

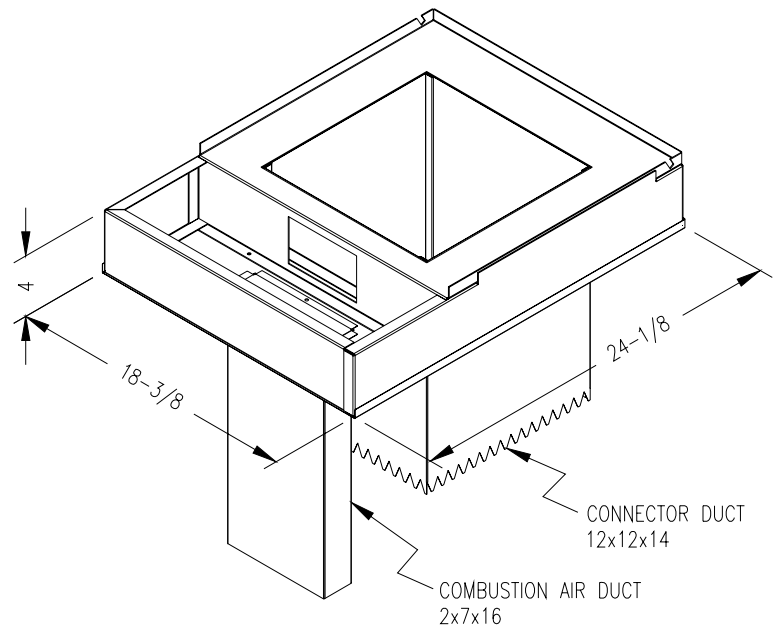

**Cottage Base
Model: 01COT-BASE**

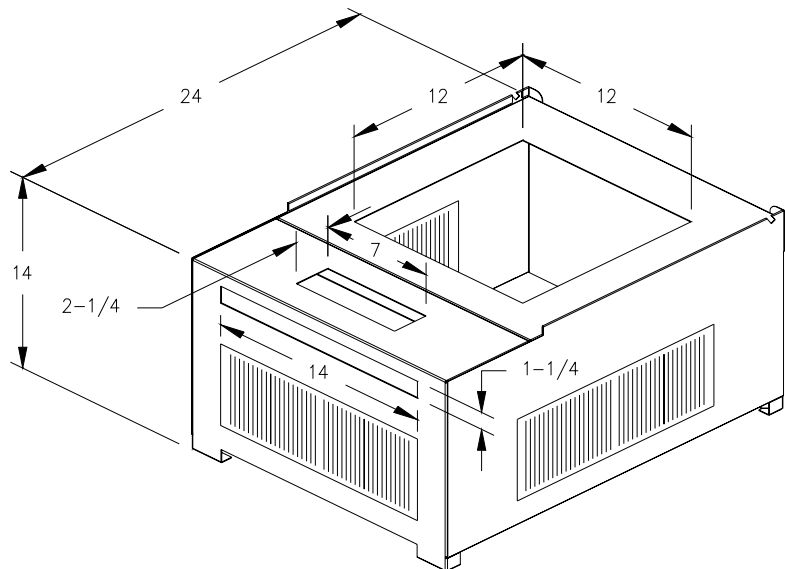

Figure 1B.

D. BASE INSTALLATION

1. Combustible Floor Base Model: 70-BASE

All installations and services must be performed by qualified service personnel.

Use the base bottom panel as a template to mark floor opening locations (see Figure 2). Cut a square opening in the floor for the supply air connector duct. Cut the opening 1-inch larger than the square template opening. (duct requires 1-inch clearance to combustible floor). Cut a combustion air duct opening in the floor 1/8-inch larger than the template opening.

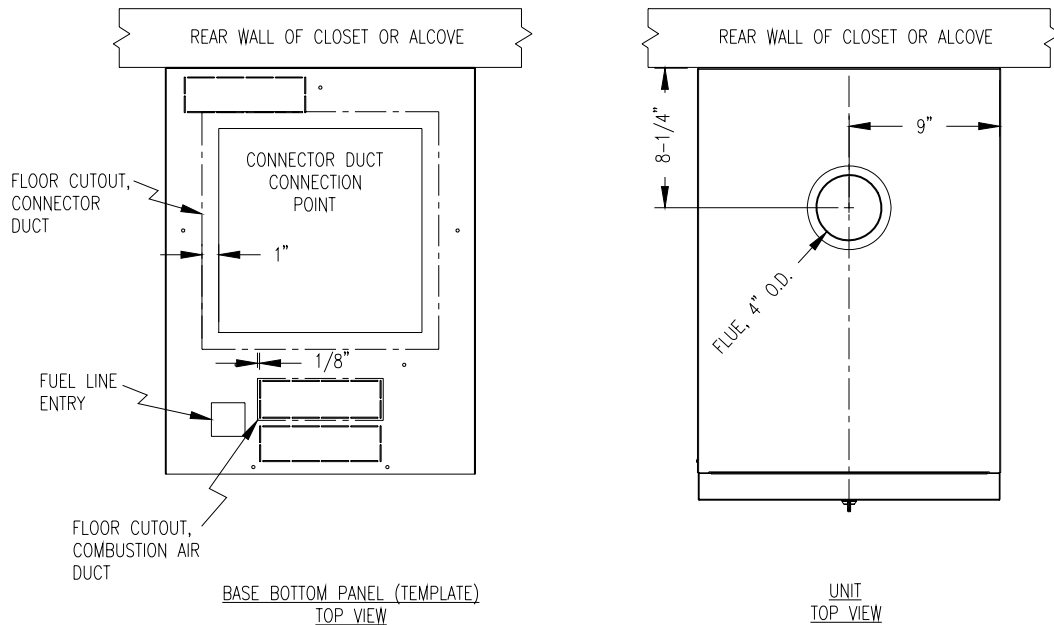

Figure 2.

After cutting openings in the floor, place the bottom panel in position. Mark the square opening location on the distribution duct at the connection point of the connector duct. Remove the bottom panel. Cut an opening in the distribution duct slightly larger than the connector duct. (refer to Figure 2 for location of this cut.) Cut the connector duct to length. Install the connector duct. Bend over each tab. Insure an airtight seal by using high temperature sealant or tape on the joint. Reinstall the bottom panel over the connector duct. Insert and secure the combustion air duct. Put the base top assembly in place (see Figure-3).

IMPORTANT: *A combustion air duct must be used. If the underside of the mobile home is skirted or enclosed (e.g. enclosed in a crawlspace), the combustion air intake should exit through the skirting, or enclosure, if at all possible. All joints and seams of supply ducts and combustion air ducts must be closed with a sealing method suitable to the application conditions and temperatures (e.g. high temperature silicone caulk and/or aluminum tape).*

Notice: If desired, combustion air can be brought in thru the roof of the dwelling and into to the furnace cabinet with Thermo Products Kit AOPS7512. See your local Thermo Pride representative for details or call customer service.

All installations and services must be performed by qualified service personnel.

If the combustion air passageway cannot terminate outside of the skirting or enclosure, a permanent opening with a minimum of 50 square inches of unobstructed infiltration (free area) for ventilation air must be provided for adequate combustion. This permanent opening must be located no less than 12 inches from the bottom of the enclosure or skirting.

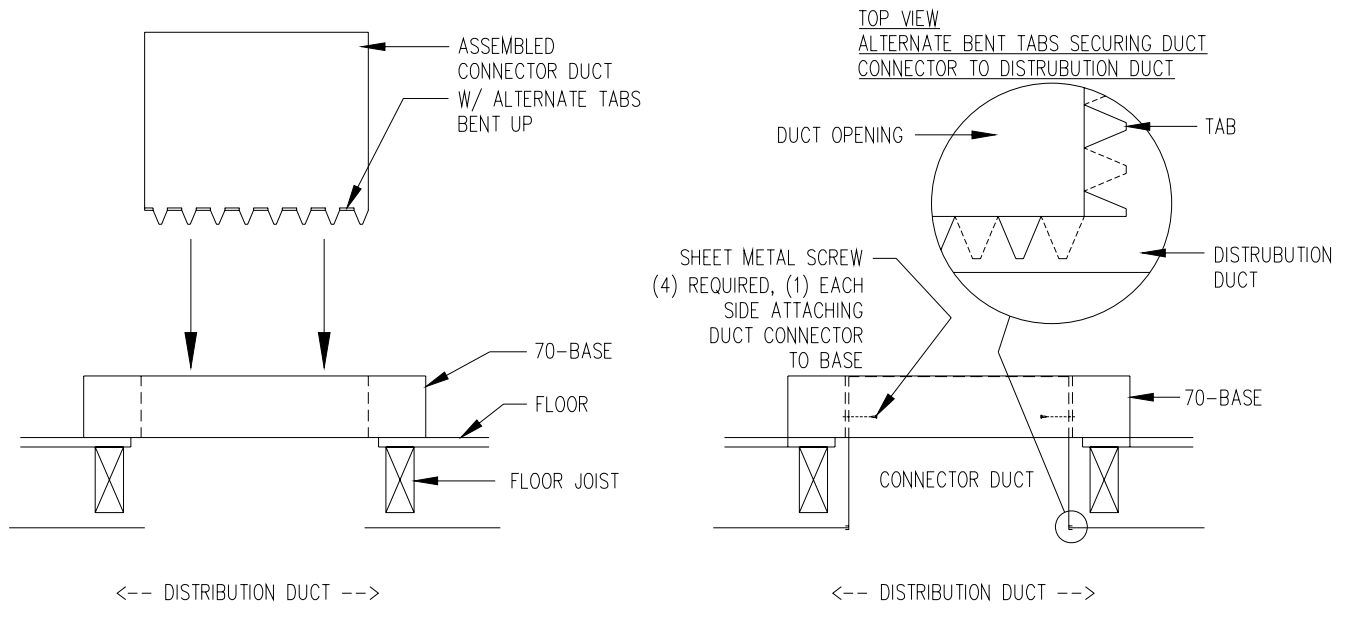

Figure 3.

Slit the corners of connector duct down to the top of the base assembly. If metal projects more than 1-inch above the top of the base assembly, trim the flanges down to 1-inch. While the top of distribution duct is being pulled up with one hand, bend down each side of the connector duct tightly to the base assembly with the other hand. This assures a tight connection between the base assembly and the connector duct and that the distribution duct will be full size. Use high temperature tape and/or high temperature silicone caulking on all joints and seams to minimize air leakage. Secure the base assembly to the floor with two screws in the front flange.

2. Cottage Base Model: OMCCOT-BASE

The OMCCOT-BASE cottage base (Figure 1B) is required for a freestanding cottage base installation. The cottage base is designed to permit the installation of an 8-inch x 12-inch register in each of the two side panels and the rear panel. This allows combustion air to be drawn from outside, or inside, the structure whichever is appropriate, or permissible. See section **G. COMBUSTION AIR** for further details regarding combustion air requirements.

All installations and services must be performed by qualified service personnel.

IMPORTANT: Adequate combustion air must be provided under all circumstances. If the underside of the home is skirted or enclosed (e.g. by an enclosed crawlspace), the combustion air intake should exit through the side of cottage base and terminate outside of the structure. All joints and seams of supply ducts and combustion air ducts must be closed with a sealing method suitable to the application conditions and temperatures (e.g. using high temperature silicone caulk and/or aluminum tape).

If the combustion air passageway cannot terminate outside of the structure, a permanent opening with a minimum of 50 square inches of unobstructed infiltration (free area) for ventilation and combustion air must be provided to the interior of the structure. Additional make-up air may need to be supplied to the interior of the structure to compensate for exhaust fans, appliances, or vents which consume air from the interior of the structure.

Refer to the assembly installation instructions included with OMCCOT-BASE cottage base for additional information.

All installations and services must be performed by qualified service personnel.

E. ALCOVE INSTALLATION

In this application, a minimum of 18 inches of clearance **must** be provided to the front of the unit. Refer to Figure 4.

Alcove installations must use the No. 70 mobile home base.

Note – access to diagnostic view port.

Refer to section **G. COMBUSTION AIR** for additional combustion air requirements.

Figure 4.

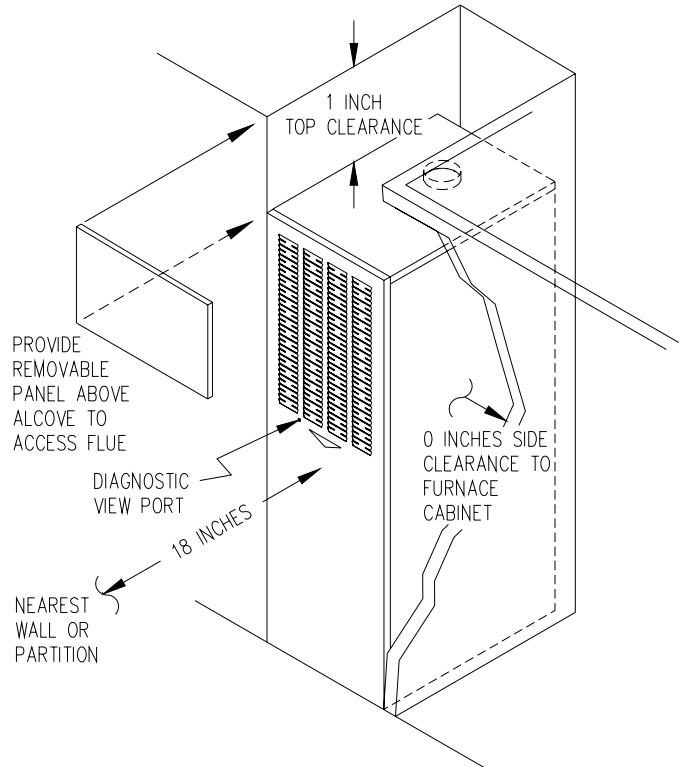

F. CLOSET INSTALLATION

⚠CAUTION: HAZARD OF ASPHYXIATION: A suction effect will occur when the furnace is operating inside the closet with the closet door closed. For proper operation, the furnace blower shall create no more than a 0.05-inch water column pressure differential between the closet and the adjoining space.

Figure 5.

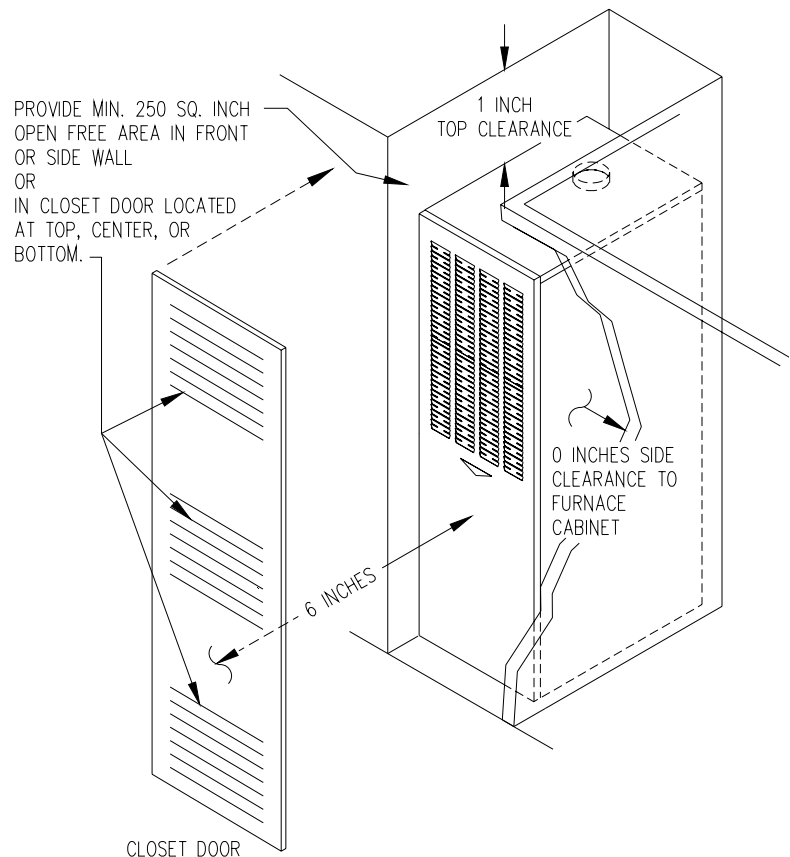

1. The return air opening into the closet is to have a minimum free area of 250 square inches, (refer to Figure 5).

All installations and services must be performed by qualified service personnel.

2. The return air opening may be located in the top, the center or (ideally) the bottom of the closet door, or side wall.

⚠WARNING: Do not obstruct any return air openings, including the return grille on the furnace. To do so may cause the furnace to activate the high temperature limit and shutdown, or it may cause asphyxiation.

3. The cross-sectional area of the return air duct leading into the closet (when located in the floor or ceiling) shall not be less than 250 square inches.
4. The total free area of openings in the floor or ceiling registers serving the return air duct system must be at least 350 square inches. At least one register must be located where it is not likely to be covered by carpeting, boxes, furniture, or any other objects.
5. Materials located in the return duct system must have a flame spread classification of 200 or less.
6. Pans made of a non-combustible material having 1 inch upturned flanges are to be located beneath openings in a floor, return air, duct system.
7. Wiring materials located in the return air duct system must conform to Article 300-22 of the latest edition of the National Electrical Code, NFPA 70.
8. Gas piping shall not be located in, or extend through, the return air duct system.
9. Refer to section G. COMBUSTION AIR for additional combustion air requirements.

G. COMBUSTION AIR

The furnace requires the proper amount of combustion air be available to combust the fuel cleanly and efficiently. An inadequate combustion air supply can result in unsafe and erratic operation of the burner, sooting of the combustion chamber and the heat exchanger, and possibly, offensive fuel odors. The combustion air intake must provide an adequate source of combustion air to the appliance. Refer to part 5.3 of the National Fuel Gas Code, ANSI Z223.1 / NFPA 54-1999, or latest edition for application specific combustion air requirements.

All installations and services must be performed by qualified service personnel.

The preferred location of the outside combustion air intake termination (e.g. an optional stainless steel intake hood, part no.370183) is through the side of the structure, skirting or enclosure. An alternate termination location is under the structure in the skirted or crawlspace area providing a minimum of 50 square inches of free area exists around the perimeter for outside combustion air to be drawn through. **NOTE:** Combustion air cannot be drawn from the occupied space of the home.

The furnace is shipped with a combustion air duct that must be installed in the bottom of the burner enclosure, before the burner is installed. This 2-inch by 7-inch duct is shipped in two pieces. High temperature silicone sealant should be applied to both vertical seams, before it is snapped together with four flanges on one end. The duct must then have high temperature silicone applied to the flanges. Then, the combustion air duct can be inserted through the opening in the floor base model no.70. When the combustion air duct has been inserted completely, secure the duct to the combustion adapter with self-tapping sheet metal screws, refer to Figure 6. Make certain that the flanges, duct, and adapter are completely sealed to the burner enclosure base with high temperature silicone caulk.

NOTE: The adapter may be cut with sheet metal shears to the appropriate size and secured over the inlet air duct opening. The adapter will convert the rectangular opening to a round connector ring. The ring will allow the connection of 3-inch I.D. flexible hose (provided) between the adapter and the inlet air boot, attached to the burner. Secure both ends of the flex hose with hose clamps (provided).

A 2-inch round to 7-inch x 4-inch rectangular, sheet metal, transition boot is supplied with the furnace for adapting a 4-inch round combustion air duct to the 2-inch x 7-inch combustion air duct. This boot has a screen inserted into the 4-inch round portion of the boot to provide a degree of protection from pests entering the furnace when the boot is terminated in the crawl space, or skirted area, directly below the furnace.

The material recommended for the combustion air duct is smooth, round, galvanized steel duct or schedule 20 PVC pipe. The maximum duct length allowed is equivalent to 40-feet of straight duct. Reduce this length by 6-feet for the intake hood and each 90-degree elbow used, and by 3-feet for each 45-degree elbow used the combustion air duct. Flexible, spiral, or corrugated duct is not recommended, due to the relatively high pressure drop associated with air movement through this type of passageway.

Notice: If desired, combustion air can be brought in thru the roof of the dwelling and into to the furnace cabinet with Thermo Products Kit AOPS7512. See your local Thermo Pride representative for details or call customer service.

All installations and services must be performed by qualified service personnel.

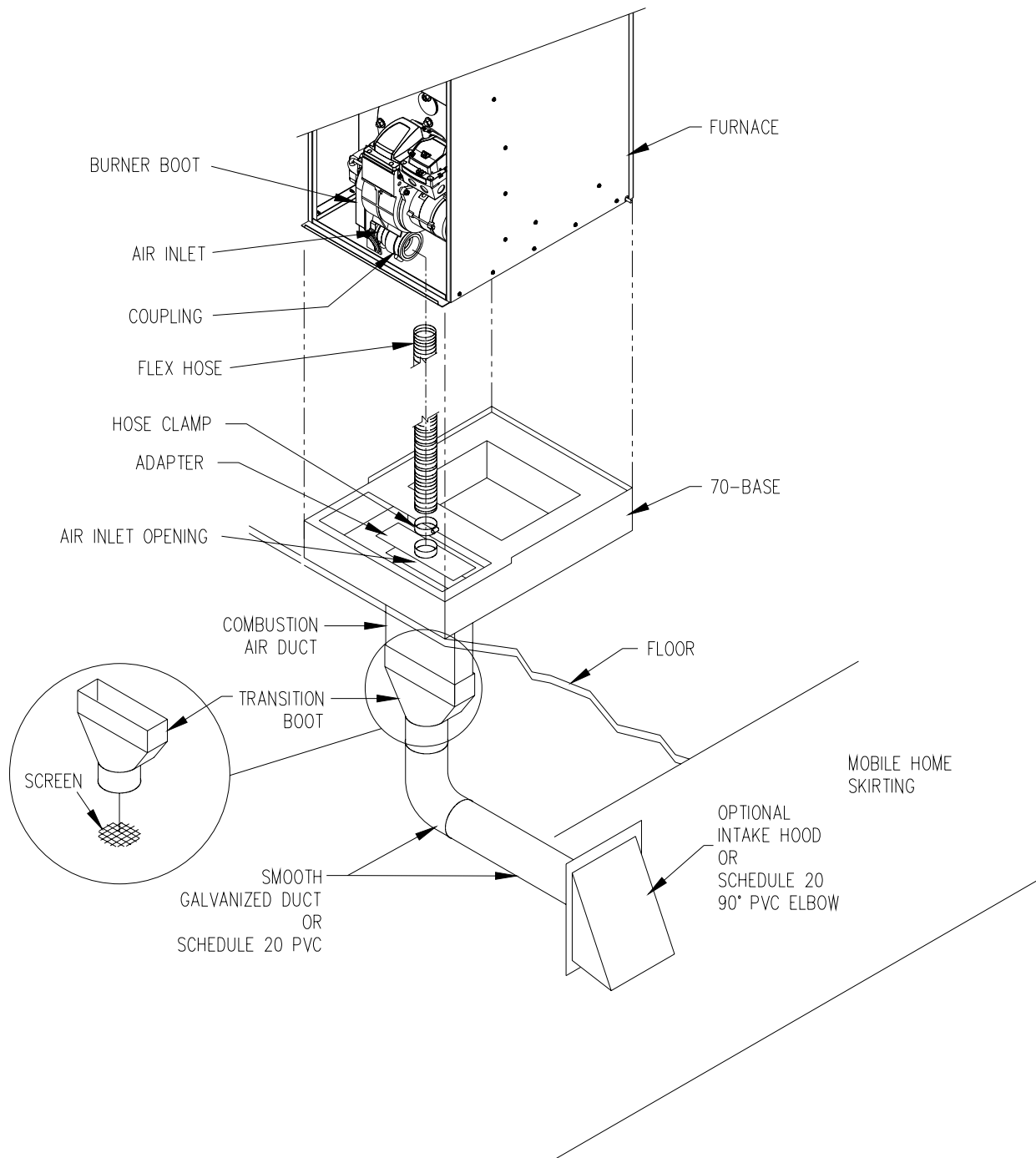

Figure 6.

All installations and services must be performed by qualified service personnel.

H. FUEL PIPING

Sizing and installation of fuel lines must be in accordance with federal, state and local regulations.

1. Oil Tank and Piping

⚠WARNING: *All local codes and ordinances take precedence with regard to tank and oil lines. All lines must have oil shutoff valves, a good pipe joint compound approved for use with oil on all pipe threads, no kinks; no sharp bends and be properly tested for leaks. Flare fittings are recommended for tubing.*

⚠CAUTION: *Do not run the oil pump dry for more than five minutes.*

Your furnace is factory equipped to operate on No. 2 distillate fuel (domestic heating) oil. In very cold weather, No. 1 distillate fuel oil may be used. Your oil supplier should be contacted for recommendations.

⚠CAUTION: *Do not use motor oil or any fuel heavier than No. 2 fuel oil..*

Burners are most commonly installed with a single stage fuel pump (refer to Figure 7). This type of fuel pump, when connected with a supply line only, is satisfactory where the fuel supply is level with, or above, the burner. This type of installation permits gravity flow of oil to the burner. When it is necessary to “lift” (raise) oil to the burner, a return line should be connected between the fuel pump and tank. This requires insertion of the “by-pass” plug into the fuel pump. If the lift exceeds approximately 10 feet, a two-stage pump should be installed with a return line. When a return line is used with either single or two-stage pumps, air is automatically returned to the tank, making the unit self-purging.

Use of continuous runs of heavy wall copper tubing is recommended. Always use flare fittings. Avoid use of fittings in inaccessible locations. **Avoid running tubing against any type of heating unit and across ceiling or floor joists.**

If possible, install the tubing under the floor. Specific information on piping, fuel pump connections, lift capabilities and tank installations is provided in the fuel pump manufacturer’s instructions.

If the oil tank is located inside the building and the tank capacity is between 10 and 660 gallons, it shall not be located within 5 feet horizontally from any source of heat, or oil-burning appliance. Furthermore, the oil tank shall not block access to utility service meters, switch panels, and shutoff valves.

If an underground tank used, the top of the tank should be below all piping in order to prevent oil discharge through a broken connection. Underwriters Laboratories requirements now stipulate that all 275 gallon and larger tanks have a bottom outlet. This is to prevent the accumulation of

All installations and services must be performed by qualified service personnel.

condensate, which causes the tank to rust. It is also recommended to use a water trap or additives to prevent condensate accumulation.

If the tank is above the burner, and gravity oil feed to the burner is permitted, a single line system may be used. The line should have a gradual slope downward of approximately 1/2 inch per foot, or more, to a point directly below where it is connected to the pump. Installing the line with a downward slope will help prevent the formation of air pockets in the line.

IMPORTANT: An oil safety valve or a delayed-action solenoid valve is required with all gravity feed oil supply systems.

IMPORTANT: The oil storage tank must be free of water, sludge and scale to prevent excessive wear and possible damage to furnace oil pump and burner nozzle. A fuel oil filter installed in the oil supply line to the burner is required.

OIL FILTER: For all installations, use a low micron, oil filter with the capacity to trap particles 10 microns in diameter, or greater. Filtering the oil supply helps to prevent nozzle clogging. Install the oil filter inside the building between the tank shutoff valve and the burner. The filter cartridge should be replaced at least once a year. The filter body should be thoroughly cleaned before installing a new cartridge.

All installations and services must be performed by qualified service personnel.

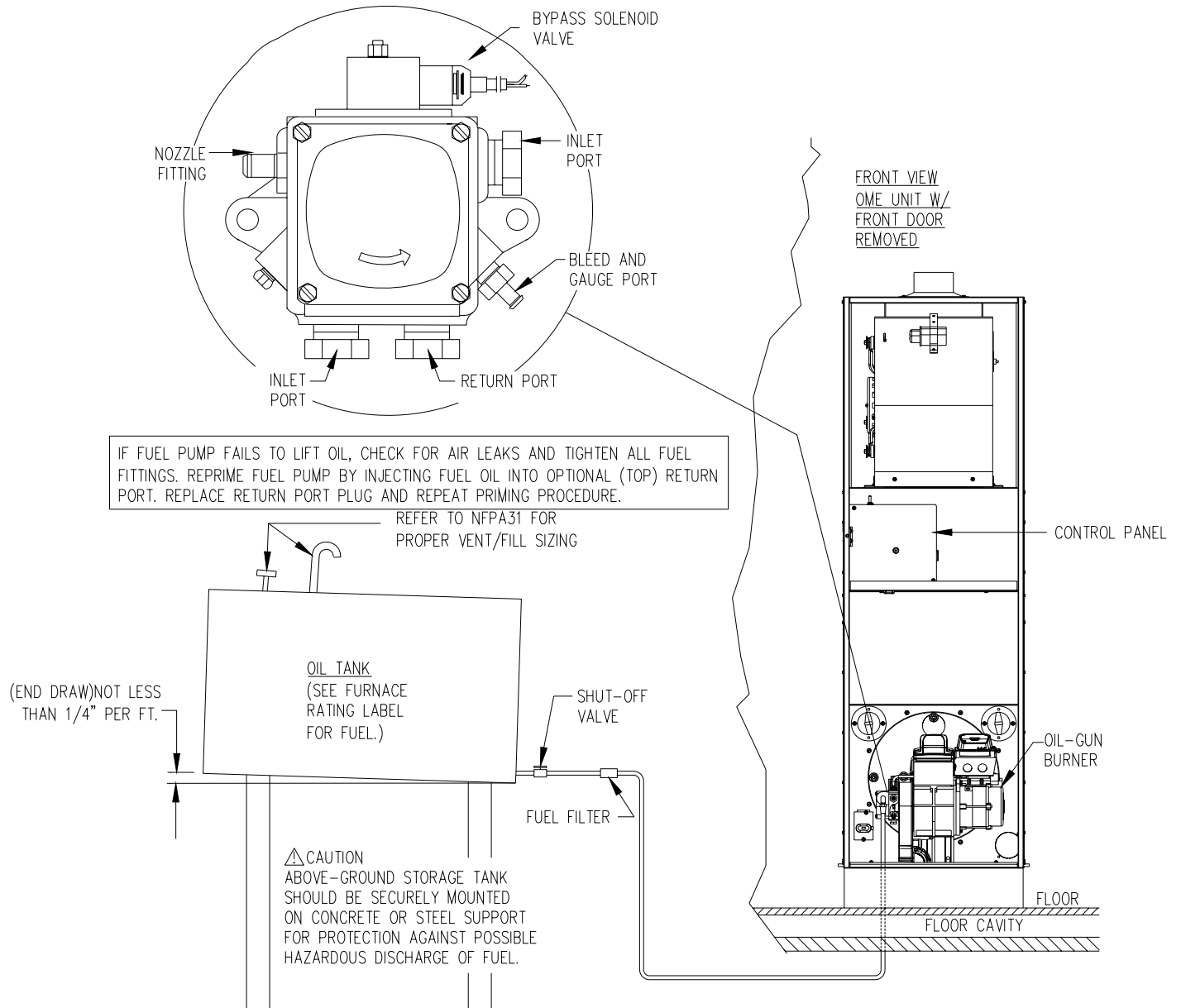

Figure 7.

J. ELECTRICAL WIRING

All electrical wiring must be installed in strict accordance with local ordinances and codes. In the absence of local ordinances and codes, all electrical wiring must conform to the requirements of the National Electric Code, ANSI/NFPA 70-1999, or latest edition.

All installations and services must be performed by qualified service personnel.

⚠CAUTION: *When testing electrical equipment, always follow standard electrical procedures and precautions.*

1. Electrical Branch Supply Circuit

Route all electrical wiring to the left side of the furnace. The power supply circuit to the furnace must be installed and grounded in accordance with the provisions of the National Electrical Code, ANSI/NFPA-70-1999, or latest edition, and all local codes having jurisdiction. Electrical Branch Supply Circuit provisions of the Canadian Electrical Code Part 1 shall be observed and followed where applicable.

2. Connection Of Power Supply Wires

- a. Remove the furnace control panel cover.
- b. Insert 120 VAC wires through the strain relief bushing (or conduit connection as applicable) on the left side of the furnace junction box.
- c. Connect the “Hot” wire to the black wire marked “**L₁**”.
- d. Connect the “Neutral” wire to the white wire marked “**L₂**”.
- e. Connect the “ground” wire to the ground lug.

3. Connection Of Thermostat Wires

NOTE: Class 1 thermostat wire must be used inside the furnace burner compartment.

- a. Insert 24 VAC wires through the plastic grommet on the left side of the furnace casing.
- b. Connect the thermostat wires to “R” and “W” for heating.
- c. Connect the thermostat wires to the room thermostat.

IMPORTANT: The room thermostat should be installed 4 to 5 feet above the floor on interior wall which is relatively free from direct sources of heat (sunlight or supply airflow) or exposure to cold (drafts from open windows and doors). The nominal anticipator setting is 0.2 amperes (refer to the thermostat literature for additional information).

Four-conductor thermostat wire is recommended for 24 VAC, low-voltage, control circuit wiring. Only 2 wires are required for the furnace (a heating application only).

Electrical Wire Diameter (AWG)	Maximum Recommended Thermostat Wire Length (feet)
24	55
22	90
20	140
18	225

All installations and services must be performed by qualified service personnel.

Once the furnace is installed, check the thermostat heat anticipator the proper nominal setting.

- a. Connect a multimeter, capable of reading milliamps (mA), in series with the low voltage wires to the thermostat.
- b. Increase the thermostat setting, or create a “call for heat”.
- c. Read the value of the thermostat current, in milliamps.
- d. Adjust the heat anticipator of the thermostat to the value read by the multimeter.

If the heat anticipator is set too high, the furnace may delay activation of a heating cycle for too long. If the heat anticipator is set too low, the furnace may cycle too frequently. Either condition may not provide optimal comfort to the homeowner.

4. BLOWER CONTROLLER INFORMATION FOR PSC MOTOR

TERMINAL DEFINITIONS & FIELD WIRING

Burner Harness Connector P1

- Pin 1- Limit switch connector.
- Pin 2- 120 VAC Line connection.
- Pin 3- Burner pilot contact.
- Pin 4&5- 120 VAC Neutral connections.
- Pin 6- Burner pilot contact.
- Pin 7&8- From oil primary control.
- Pin 9- Limit Switch Input (LSI).

Field Wiring to Burner

	Pilot (Tstat)	Neutral	Line
Harness Wires	Yellow Wires	White	Red
Beckett Connections	T-T terminals	White	Black

Thermostat / Humidistat connections

- “C” Common / ground
- “W” Thermostat call for heat
- “R” 24 VAC to thermostat
- “G” Thermostat call for fan
- “Y” Thermostat call for cool
- “DEHUM” Humidistat call for dehumidification (TXV systems ONLY)

Male quick connect terminals.

- “S1-3” 120 VAC Hot
- “N1-7” 120 VAC Neutral
- “EAC” Electronic Air Cleaner (120 VAC) connection
- “FAN” Fan On Signal
- “X” 24 VAC from transformer
- “C” 24 VAC common from transformer
- “CC” Compressor Contactor

All installations and services must be performed by qualified service personnel.

“CC_COM”	Compressor Contactor Common
“LOW”	Continuous Blower Speed
“HEAT”	Blower heat speed tap
“COOL”	Blower cool speed tap

A. Inputs

Power supplies

Line voltage is applied between the “S1” and “N1” quick connect terminals. 24 VAC Class II Transformer secondary voltage supplied to X and C

Limit switch

The 120 VAC optically isolated limit switch input is connected on pin P2-1 & 9. Refer to the Heat Mode section for the control operation.

Thermostat call for heat “W”

24 VAC thermostat input. A call for heat is recognized when the thermostat connects “W” to “R”. This input has an indicator LED that will light when the control receives a call for heat. Refer to the Heat Mode section for the control operation.

Thermostat call for fan “G”

24 VAC thermostat input. A call for fan is recognized when the thermostat connects “G” to “R”. This input has an indicator LED in that will light when the control receives a call for fan. Refer to the Fan Mode section for the control operation.

B. Outputs

PSC Control

The control shall control a five speed indoor blower motor. Rating shall be 10 FLA, 30 LRA @ 120 VAC. Connections are made via 0.250 x 0.032” male quick connect terminals labeled “HEAT”, “COOL”, and “LOW”. “HEAT” is energized when the heat speed blower is to run. “COOL” is energized when the Cool speed blower is to run. “LOW” is energized during a call for fan is received or a call for dehumidification is received.

Oil Burner

Control

The control provides dedicated contacts to operate the T-T input of an oil primary control.
Rating shall be class 2 – 24 VAC pilot duty @ 24 VAC (<200mA).

Power

The switched 120 VAC power from the LIMIT switch passes through the board between Pins 1 & 2 of connector P1.

EAC (electronic air cleaner)

All installations and services must be performed by qualified service personnel.

The control provides a 120 VAC output for an electronic air cleaner. This output is energized whenever the fan motor is energized (either low, heat or cool speed). Connection is made via male quick connect terminal labeled “EAC”.

Humidifier

The control provides a 120 VAC output for a humidifier. Connections are made to a male quick connect terminal labeled “FAN”. The control does not switch this output, it provides a pass-through connection from P1-7 from the switched primary voltage of the Burner Module.

Status LED

A red LED is provided to indicate any thermostat input has been recognized by the microprocessor on the control. See Diagnostic Features for a function description of operation.

Thermostat Input LEDs

Four green LEDs are placed beneath their respective thermostat connections (W, Y, G and DEHUM) and operate whenever a call is present. See Diagnostic Features for a function description of operation.

C. Operating Modes

Standby Mode

All outputs are off and the control is waiting for a thermostat demand. The thermostat inputs, and limit switch are continuously monitored. The control initiates action when a thermostat call is received or limit switch opens.

Fan Mode

A call for fan (“G”) is received from the thermostat. If no other mode is calling for blower operation, the control will operate the fan relay (K4) and power the “Low” blower speed terminal. The fan mode will be operated as long as the “G” input is calling and neither the Heat mode nor the Cool mode is calling for blower operation. When the Heat and Cool modes call for blower operation, their respective outputs will take precedence after their respective turn-on time delays have expired.

Cooling Mode

A call for cool (“Y”) is received from the thermostat. If the heat mode is not active or the anti-short cycle delay is not in effect, the control will energize the “CC” terminal and after a 10 second power demand conservation delay energizes the “COOL” speed blower terminal.

When the call for cool is satisfied, the “CC” terminal is de-energized and the cooling off delay of 45 seconds is started. Forty-five seconds later the “COOL” speed blower terminal is de-energized and the control reverts to Standby Mode.

Dehumidification Operation

If a call for dehumidification is received while the Cool Mode is active, blower speeds will be reduced. The PSC “COOL” blower speed terminal (1158-100 model only) will be de-energized and “Low” blower speed will be energized.

Anti-Short Cycle Operation

To prevent compressor short cycling, a call for cooling will be ignored for four minutes after the termination of any cooling call. The anti-short cycle delay is also in effect at power-up.

All installations and services must be performed by qualified service personnel.

Heat Mode

When a call for heat (“W”) is received from the thermostat, if the “Cool” mode is not already active, the “T-T” terminal is energized and the blower on delay is started. The on-off pattern of DIP switch SW2 (positions 1 and 2) select one of four blower on delay values (see Table 11). When the delay time has elapsed, the “HEAT” blower speed is energized. The control remains in steady heat mode until the thermostat is satisfied. When the call for heat signal is removed, the “T-T” terminal is de-energized and the blower off delay is started. The on-off pattern of DIP switch SW2 (positions 3 and 4) select one of four blower off delay values (see Table 11). When the delay time has elapsed, the “HEAT” blower speed terminal is de-energized.

All installations and services must be performed by qualified service personnel.

DIP SWITCH 2 SECTION STATE				BLOWER DELAY TIMES			
	1	2	3	4		ON - SEC	OFF - MIN
	OFF	OFF				30	
FACTORY SETTING	ON	OFF				60	
	OFF	ON				120	
	ON	ON				240	
			OFF	OFF			2
FACTORY SETTING			ON	OFF			4
			OFF	ON			6
			ON	ON			8

Table 11: ON and OFF Blower Delay Time Switch Settings

Blower On and Off Delays

Four Heat blower on and four blower off delays are selected by two dip switches for each function. Refer to Table 11 for specific delay values.

PSC TROUBLE SHOOTING

DIAGNOSTIC FEATURES

The control board is equipped with 4 green Input Status LEDs and 1 red Board Status LED. These are intended to provide a quick view into furnace performance without requiring a voltmeter.

The green Input Status LEDs are driven by the “Y”, “W”, “G”, and “DEHUM” inputs and are located directly below those inputs. They will light to indicate the presence of these signals.

The red Board Status LED has two functions:

It will light when the board recognizes a valid input signal and will stay lit until all valid signals are removed. This is intended to show that the board is functioning and able to respond to input signals.

It will flash rapidly while 120VAC is missing from the LIMIT switch. This is intended to give a quick visual indication of the High Limit switch.

All installations and services must be performed by qualified service personnel.

K. BURNER INSTALLATION

The burner mounts to the furnace on three mounting bolt studs, located on the burner mounting plate, in the lower portion of the vestibule, directly in front of the heat exchanger.

The burner insertion depth has been fixed by the factory for the design-specified, combination of the air tube length and the combustion chamber used with the furnace. The combustion chamber is pre-positioned during the assembly process and held in place by the drum and mounting plate. The burner insertion depth is not field-adjustable.

Should access to the chamber be necessary, refer to the exploded diagram, in the back of this manual, to identify replacement parts.

To install and ready the burner for firing, follow the steps below for both furnace models.

1. With electrical power connected to the furnace, turn off all electrical power to unit.
2. Remove the front lower access panel.
3. Mount the burner to the furnace. Install the flange gasket over the mounting studs and secure the burner flange to the furnace using hex head machine screw nuts, provided in the Parts Kit.
4. Connect the red and white wires from the burner harness to the black, red and white burner power leads found underneath the primary control. Then connect the two yellow wires to the “T & T” terminals on the front of the primary control.

For the oil burner installation only:

5. Determine whether an oil return line is required and connect the fuel oil piping to the burner oil pump through the base of the unit.
6. Turn on electrical power to the furnace. Cause or simulate a “call for heat” to bleed air from the oil line at the oil pump. (Temporarily, connect the two thermostat leads to cause the oil pump to run.)
7. With all oil shutoff valves open, open the air-bleed valve on the oil pump and capture the oil flow in a container until all traces of air in the line are gone.
8. Close the air-bleed valve. Check for and correct any oil leaks. The furnace is now ready for burner adjustment. Refer to the following “BURNER OPERATION AND ADJUSTMENT” section.

L. BURNER OPERATION AND ADJUSTMENT

⚠WARNING: NEVER burn garbage or refuse in the furnace. NEVER try to ignite oil or gas by tossing burning papers or other material into your furnace.

All installations and services must be performed by qualified service personnel.

⚠WARNING: If you do not follow these instructions exactly, a fire or explosion may result causing personal injury, loss of life or property damage.

⚠WARNING: NEVER use gasoline or a mixture of oil and gasoline to start the burner or furnace.

1. Qualified service personnel must perform the first lighting of the burner.
2. The burner instructions must be read and understood before any attempt is made to light this burner.

NOTE: For the sequence of burner operations, see individual burner manual. To successfully service and initially set up this furnace you must use the following instruments:

[Items (a)-(e) ... apply to both oil and gas furnaces), item (f) ... applies to gas units only, and items (g)-(h) ... applies to oil units only]

- a. Carbon dioxide (CO₂) or oxygen (O₂) analyzer.
- b. Flue gas thermometer (range 100°F to 1000°F) and temperature-measuring device (range -40°F to 240°F, for return and supply air temperatures).
- c. Carbon monoxide (CO) detector
- d. Electrical multimeter
- e. Liquid, U-tube type manometer or equivalent pressure measuring instrument (range: 0 – 28 in.W.G.)
- f. Smoke spot tester or equivalent smoke density measuring device
- g. Oil pressure gauge (range: 0-150 PSIG)
- h. Vacuum gauge (range: 0-30 in. W.G. vacuum)

Turn the main service switch that provides power to the furnace to the “off” position. Set thermostat above room temperature. Open all fuel supply valves. Bleed air out of fuel supply line, if not already completed (for oil, power must be “on” to the burner and the pump must be operating to expel air in the supply line).

When ignition is established, if necessary, make a preliminary burner air adjustment to attain a clean combustion flame (one which does not create smoke by eye). The flame may be viewed through the overfire inspection cover (see exploded diagram of replacement parts for location identification). After the furnace is warmed up to a steady-state condition (about 15 minutes), the final burner adjustment should be made using combustion instrumentation for measuring carbon dioxide (CO₂) or oxygen (O₂), carbon monoxide (CO), smoke, and stack temperature. In order to achieve the most efficient combustion possible, the following steps must be taken.

IMPORTANT: To achieve proper combustion and efficiency instruments must be used to secure CO₂, O₂ and CO readings.

All installations and services must be performed by qualified service personnel.

1. **CARBON DIOXIDE (CO₂) or OXYGEN (O₂):** Take a CO₂ sample from the flue pipe or vent connector at a position close to the furnace. It is possible to achieve relatively high CO₂ (or low O₂) readings with low stack temperatures to produce maximum combustion efficiency. However, the CO₂ and O₂ values recommended are slightly less, though this means slightly lower efficiency, to allow the burner to better tolerate adverse operating conditions, such as a cold heat exchanger, downdraft conditions, heating content changes in the fuel. This working tolerance means less service and maintenance during heating seasons as well as a reduced chance of producing carbon monoxide under adverse conditions.
2. **CARBON MONOXIDE (CO):** As described above, take a flue gas sample from the flue pipe or vent connector at a position close to the furnace. The amount of CO generated by combustion ideally should be zero or only a trace. In all cases, it must be less than 50 PPM. Carbon monoxide is a colorless and odorless gas, but it is toxic compound. The production of significant quantities of CO is a strong indicator of incomplete combustion. Check the fuel supply and the burner for fuel leakage. Check for an inadequate supply of clean air for combustion. Also, check for a restricted or blocked flue, vent, or chimney.
3. **SMOKE:** (oil burners only) A smoke sample should be drawn from the flue pipe or vent connector at a position close to the furnace. For the greatest efficiency, if the first smoke reading is "0", close the air shutter on the burner until a trace smoke reading is obtained.
4. **FLUE GAS TEMPERATURE:** The flue gas temperature will vary to some degree depending on the heating content of the fuel, the amount of combustion air, and airflow across heat exchanger. In general, the lower the stack temperature, the higher the efficiency. However, stack temperatures under 350°F may cause flue gases to condense, which in turn may cause excessive metal corrosion.
5. **TEMPERATURE RISE:** Supply air temperature (measured twelve inches into trunk, away from radiant heat from the furnace) minus (-) return air temperature, or

Temperature rise = Supply air temperature - Return air temperature.

The temperature rise across the furnace heat exchanger operating at steady-state conditions (about 15 to 20 minutes) should not exceed 100°F. The normal comfort range is between 70°F to 100°F. A lower temperature rise usually results in a higher system efficiency.

⚠CAUTION: If the temperature rise exceeds 100°F, the heat exchanger may fail, voiding the heat exchanger warranty resulting in property damage, personal injury or loss of life.

M. FLUE GAS COMBUSTION ANALYSIS

All installations and services must be performed by qualified service personnel.

⚠WARNING: *Burner adjustments must be confirmed by instrumentation. Failure to use accurate or calibrated instrumentation to correctly setup the burner may result in reduced efficiency, sooting, and/or the production of hazardous carbon monoxide gas.*

For typical burner combustion analysis results, refer to the table below.

BURNER COMBUSTION PARAMETERS

FURNACE MODEL OME-72	LOW-FIRE	HIGH-FIRE
FUEL TYPE	#1 OR #2 FUEL OIL	#1 OR #2 FUEL OIL
CO (CARBON MONOXIDE)	<u>50PPM OR LESS</u>	<u>50PPM OR LESS</u>
CO2 (CARBON DIOXIDE)	10.5-11%	11-12%
O2 (OXYGEN)	4.5-6%	4.5-6%
SMOKE SPOT RATING	0	0
AIR SHUTTER ADJUSTMENT	OPEN TO POSITION 3.5	OPEN TO POSITION 3.5

All installations and services must be performed by qualified service personnel.

V. DEALER MAINTENANCE

THIS SECTION IS ONLY TO BE PERFORMED BY TRAINED, QUALIFIED SERVICE PERSONNEL, AND NOT BY THE FURNACE OWNER.

A. TROUBLESHOOTING

Note: Check diagnostic code through view port prior to removing doors.

⚠CAUTION: *When testing electrical equipment, always follow standard electrical procedures and precautions.*

1. Check for line voltage (110-120VAC) to the furnace. If there is no line voltage applied to the furnace, check that disconnecting switch is “on”, fuses or circuit breakers have not blown or tripped.
2. Make sure thermostat is “calling for heat”.
3. Check for adequate fuel supply and pressure. Are all the fuel shutoff valves are open?

All installations and services must be performed by qualified service personnel.

TROUBLESHOOTING FLOWCHART

Note: Check diagnostic code through view port prior to removing doors.

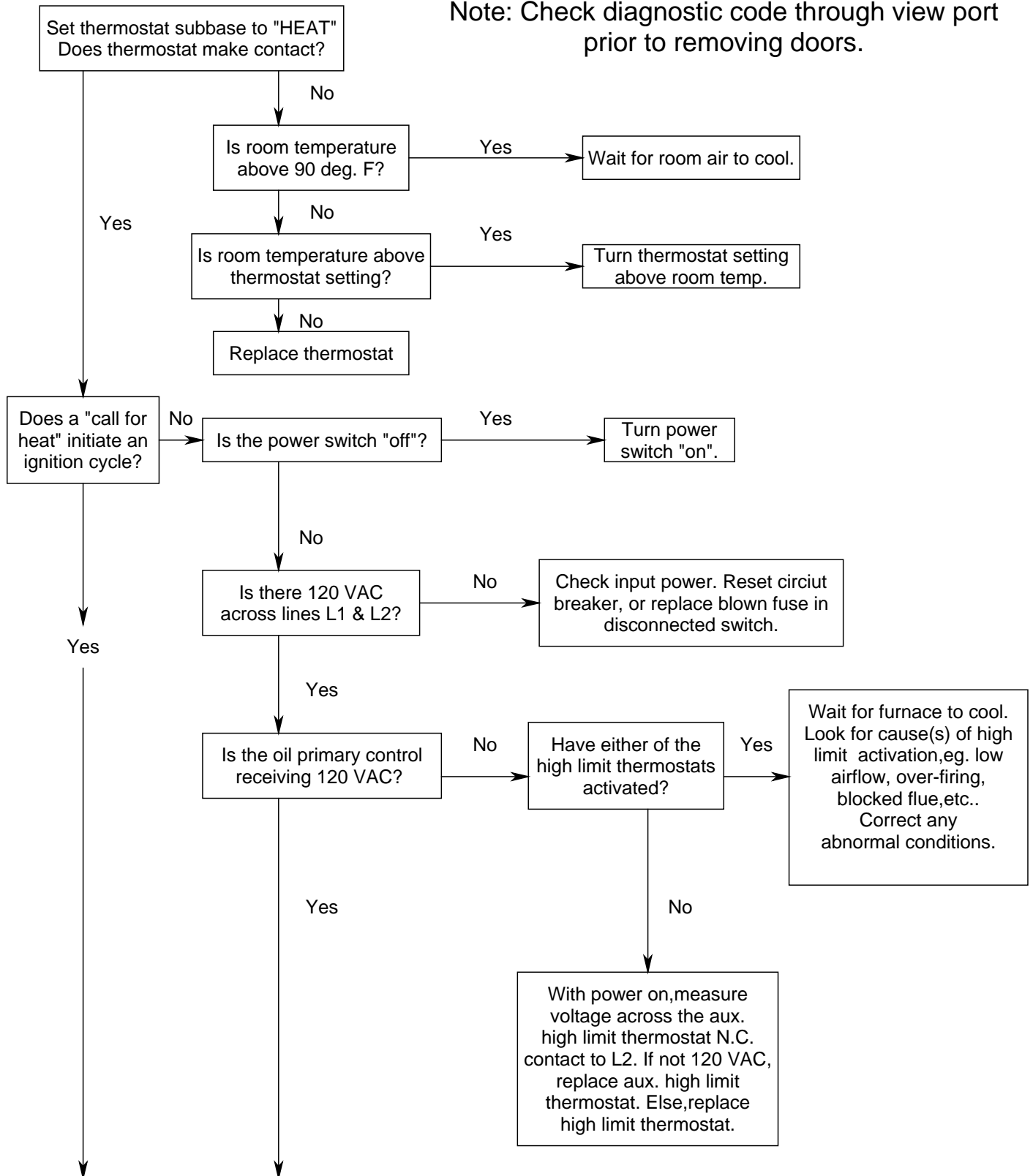

All installations and services must be performed by qualified service personnel.

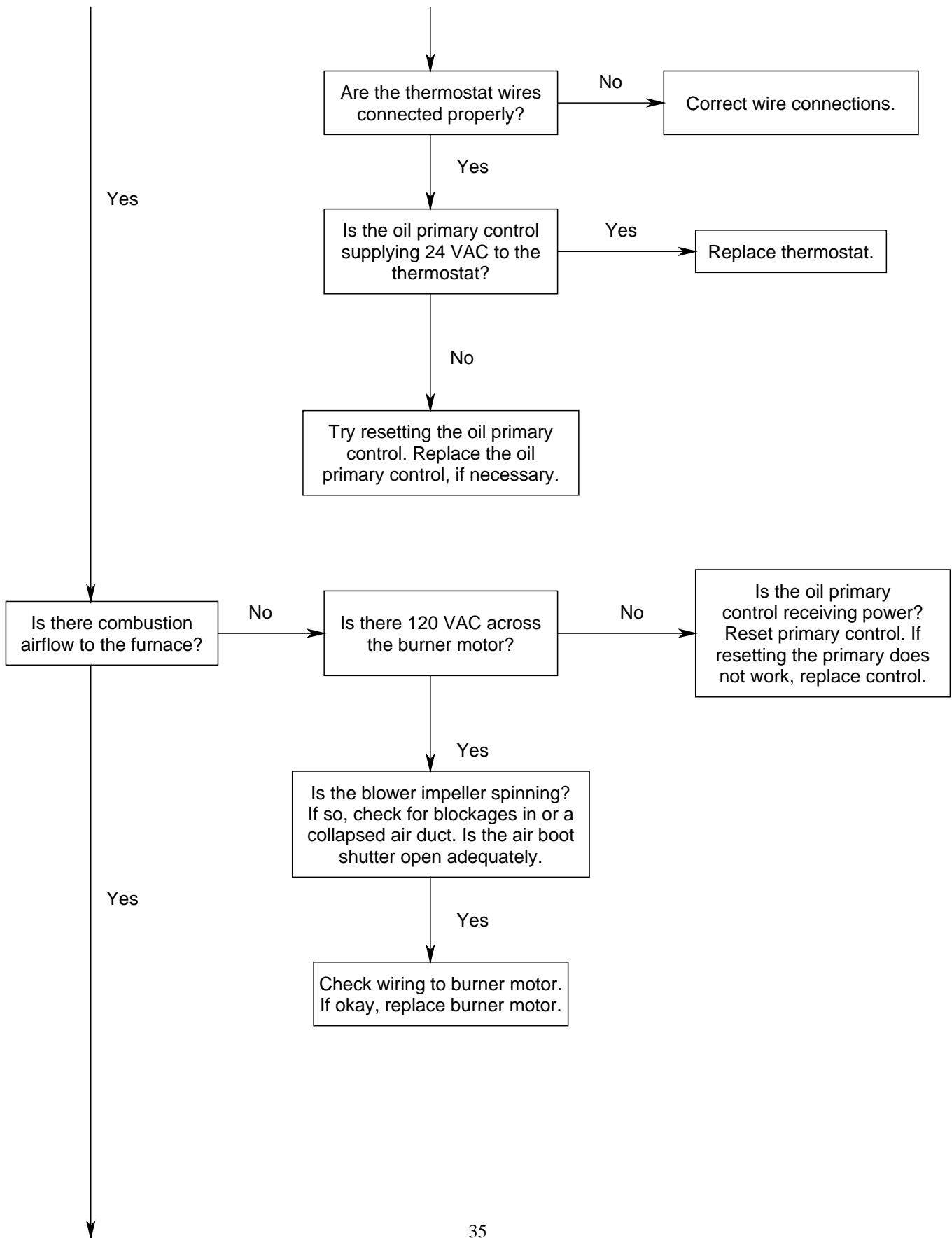

All installations and services must be performed by qualified service personnel.

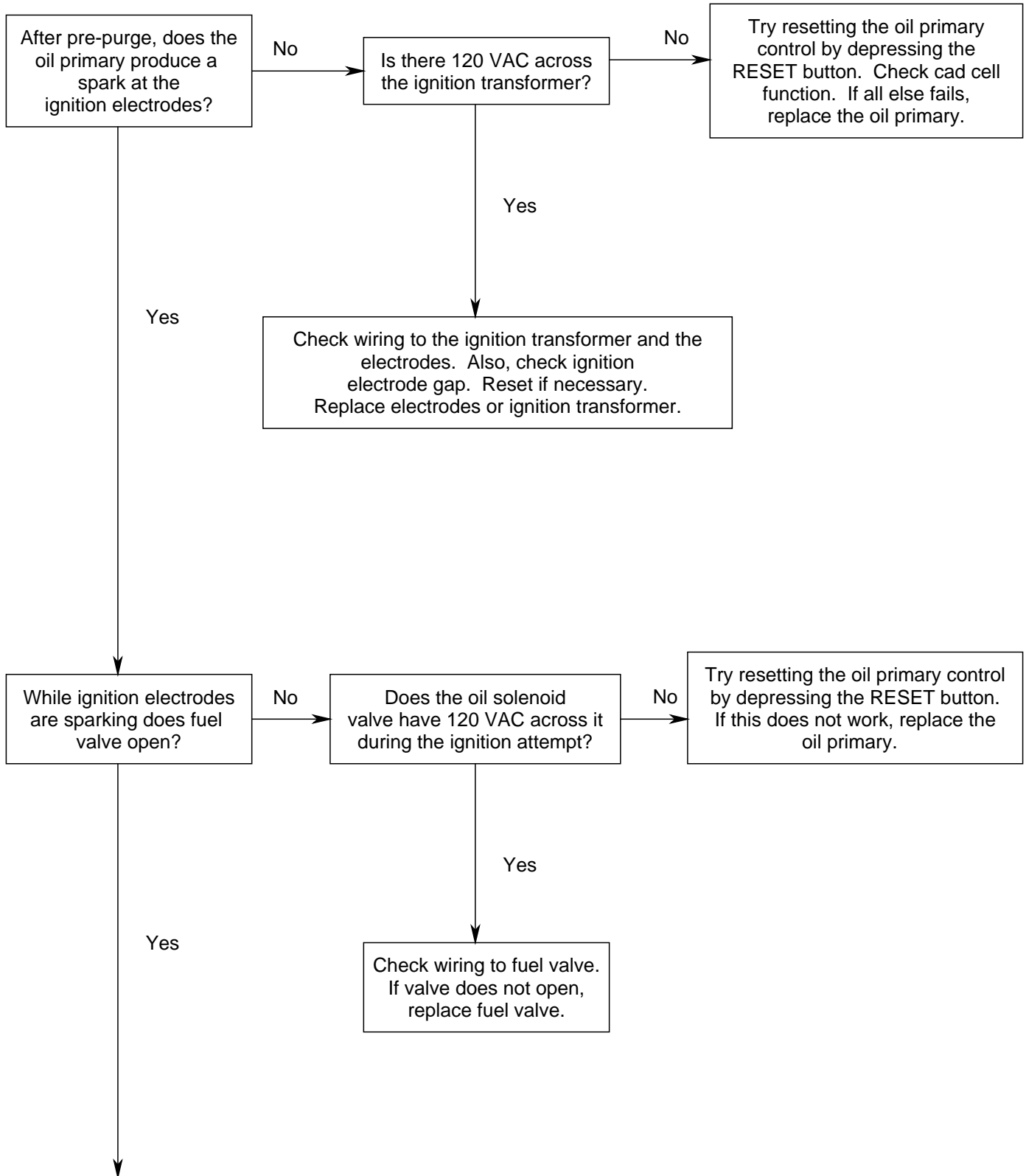

All installations and services must be performed by qualified service personnel.

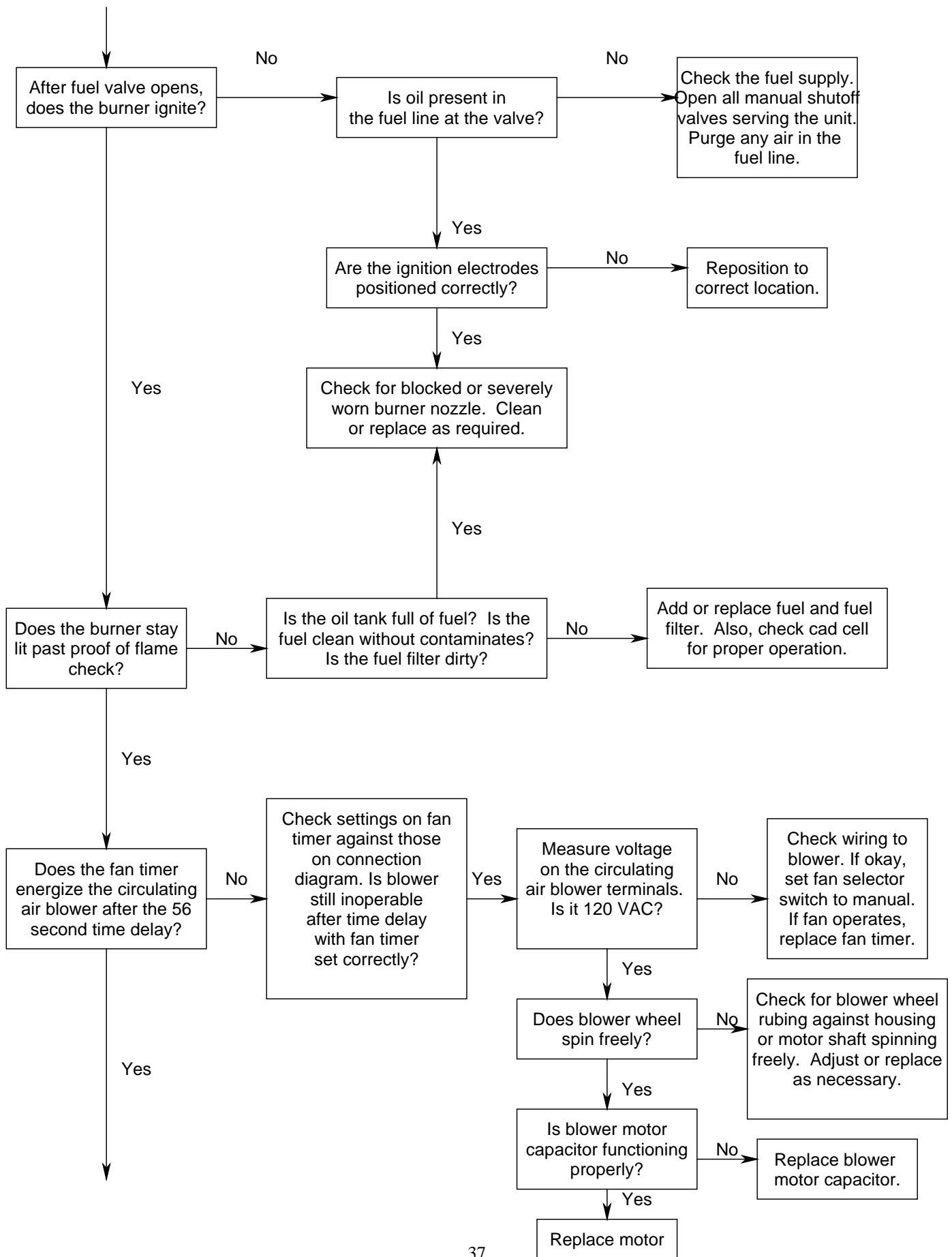

All installations and services must be performed by qualified service personnel.

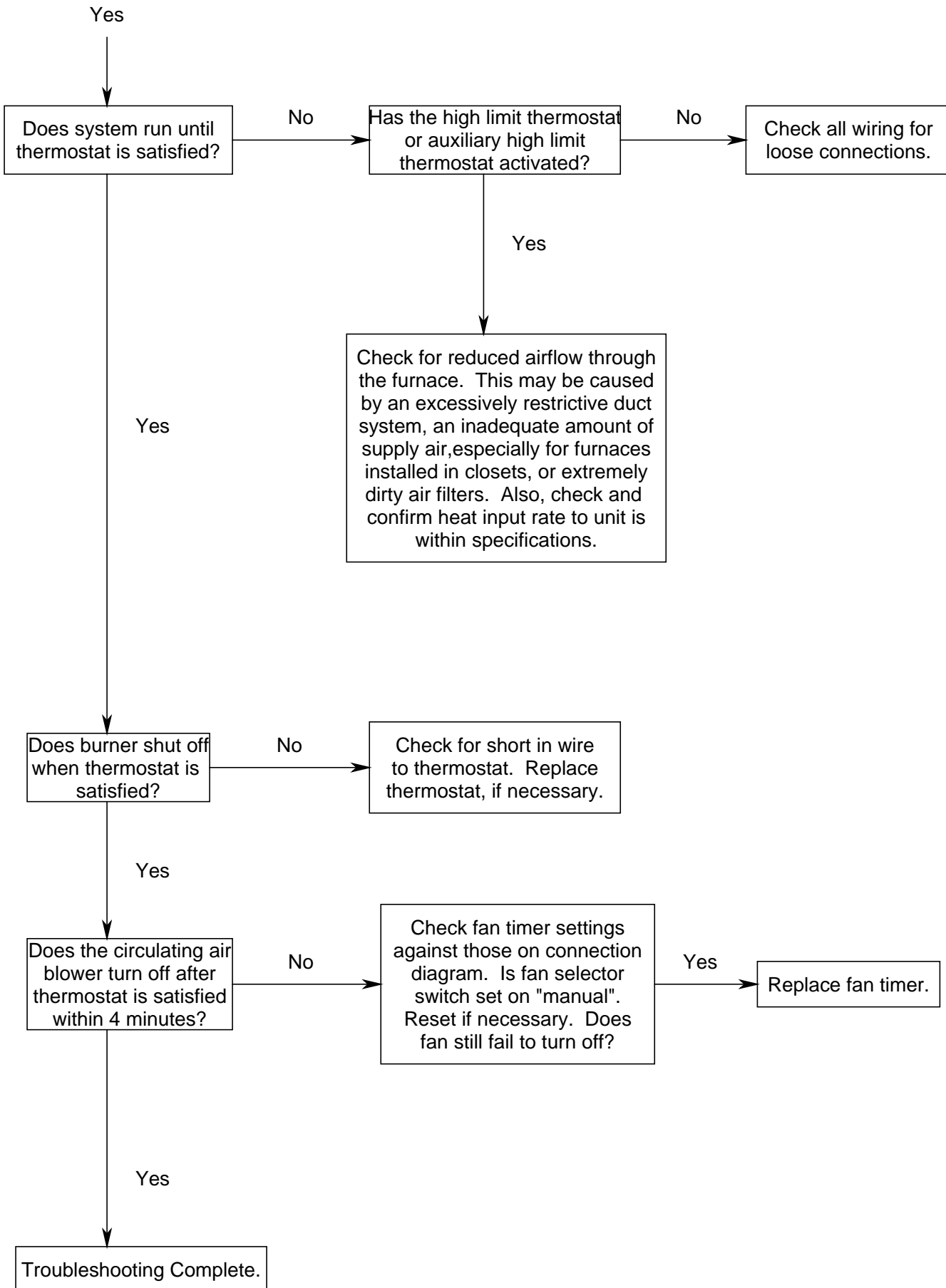

All installations and services must be performed by qualified service personnel.

B. CAD CELL CHECKOUT PROCEDURE:

1. Remove cad cell lead wires, then start the burner. Shortly after burner starts, place a temporary jumper between terminals f & f of the oil primary control. Connect ohmmeter across cad cell lead wires - resistance should be less than 1600 ohms.
2. Stop the burner and remove temporary jumper.
3. With the burner off, check dark cell resistance across cad cell lead wires. Resistance should be greater than 20,000 ohms. If cell resistances are different from above, recheck wiring, location of cell, etc. If necessary, replace plug in portion of cell, (Part No. 350104).
4. Reconnect cad cell lead wires. Check out the oil primary control according to the instructions packed with the control.

C. HEAT EXCHANGER CLEANING INSTRUCTIONS

⚠WARNING: *The heat exchanger must be cleaned by a qualified service person.*

For oil-fired units, it is important to inspect and clean the heat exchanger once a year, or as necessary, to remove any build-up of soot. A layer of soot on the inside of the heat exchanger will act as an insulator, reducing heat transfer, resulting in reduced efficiency

To clean the heat exchanger,

1. First, turn off all power to the unit.
2. Remove cleanout plugs, the vent connector pipe to the chimney, the burner and the burner mounting plate.
3. With access to the inside of the heat exchanger through the burner cleanout openings and the vent pipe connection, it is now possible to use a long, flexible wire brush and an industrial-type vacuum cleaner to remove any soot build-up.

NOTE: A one inch (outside diameter) vacuum cleaner hose will fit into the radiator.

All installations and services must be performed by qualified service personnel.

To vacuum and brush the outer radiator of the heat exchanger, go through the cleanout openings in both directions, as shown in Figure 8.

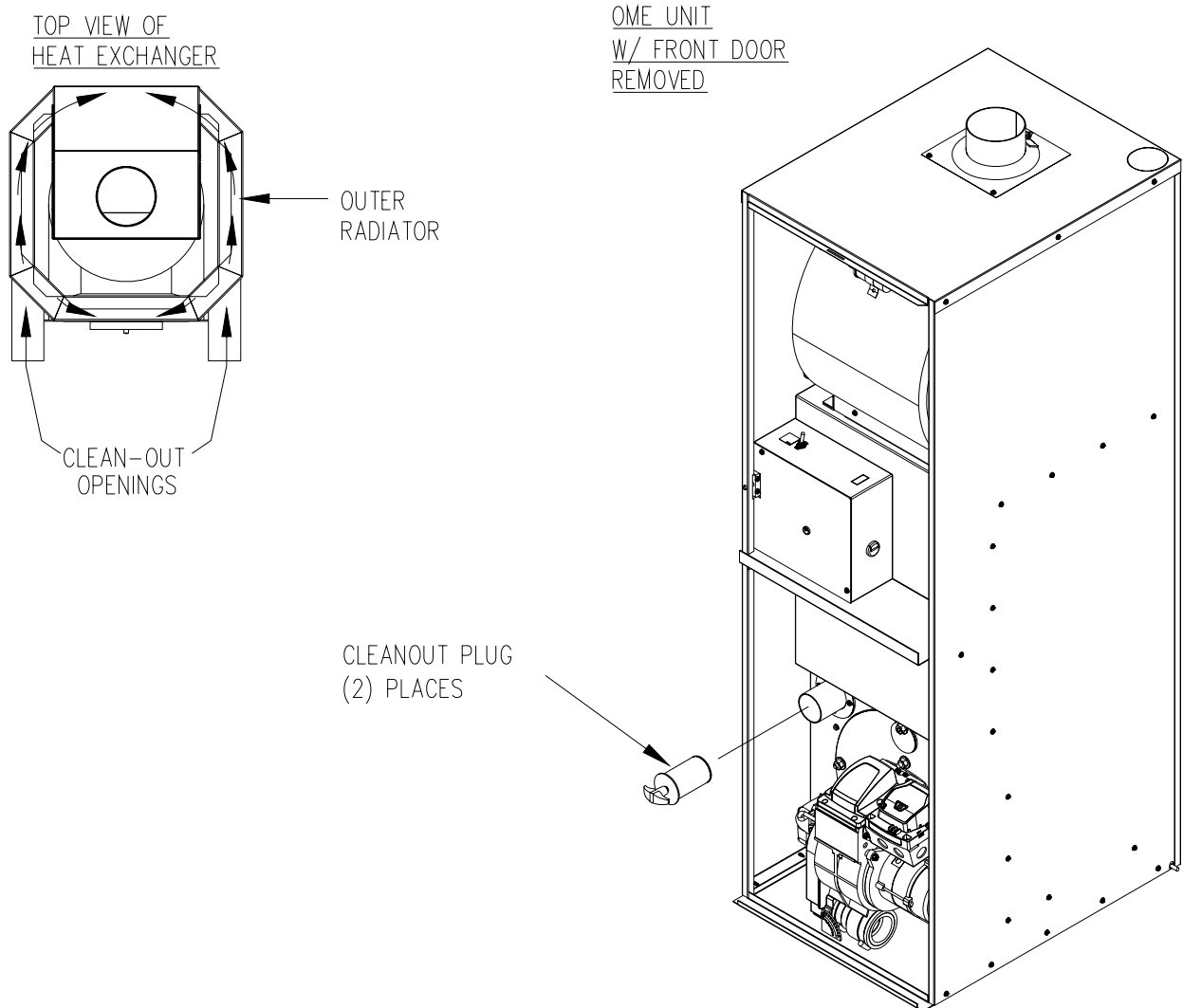

Figure 8.

Reassemble the furnace to the original factory-built condition. Remount the burner, being certain that the air tube is properly inserted into the chamber opening. If heavy soot deposits were found in the heat exchanger, this indicates that the burner may be out of adjustment. Reset the burner, as indicated under the “BURNER OPERATION AND ADJUSTMENT”, SECTION L. **⚠WARNING:** Do not start burner unless blower door is secured in place.

All installations and services must be performed by qualified service personnel.

D. CLEANING OR REPLACING FLUE PIPES

Flue pipes should be inspected during the annual maintenance check-up or during each subsequent service call.

Check all flue pipes for restrictions due to soot, or carbon build-up, as well as foreign matter, or any materials, that cause the venting system to restrict the proper venting of combustion products. If a restriction is found, the flue pipe **must** be cleaned or replaced to ensure proper venting.

Flue pipes should also be inspected for any signs of corrosion, deterioration or leakage that may cause combustion by-products to infiltrate the home or indoor environment.

If signs of corrosion, deterioration or leakage are evident, the flue pipe **must** be replaced with a properly sized, agency-approved, flue pipe.

E. EXTENDED SHUTDOWN

If this furnace is shut down or off for an extended period of time, several steps can be taken to help insure a smooth and reliable start.

ON SHUT DOWN:

1. Close the fuel supply shutoff valve(s).
2. Turn the furnace power switch “off” and disconnect electrical power to the unit.
3. Fill the oil tank to prevent condensation (oil units only).
4. If shutdown exceeds one season, an oil stabilizer should be added to the oil tank as recommended by your oil supplier (oil units only).

ON START-UP:

1. Have the heating system (and furnace) inspected and started by a qualified service person.
2. Check for a clean, adequate supply of fuel.
3. Set the room thermostat above room temperature.
4. Open all shutoff valves in the fuel supply line.
5. Turn “on” the main power at the disconnecting switch and at the furnace power switch to start the burner. If the burner does not start, immediately reset the burner primary (ignition) control module. On oil furnaces, if required, vent the fuel of air as soon as the burner motor starts. If the burner stops during venting, wait three to five minutes before attempting to restart.

All installations and services must be performed by qualified service personnel.

⚠CAUTION: *Do not attempt to start burner when excess fuel has accumulated inside the furnace.*

6. Follow the “BURNER OPERATION AND ADJUSTMENT” procedure in Section L.

VI. USER INFORMATION SECTION

A. WARNINGS AND CAUTIONS:

⚠WARNING: *If you suspect there is a problem with the furnace, pertaining to the venting system or any other related problem, immediately contact a qualified service agency. If a service agency is not available, contact your fuel supplier.*

⚠WARNING: *Personal injury or property damage could result from major repair or service of this furnace by anyone other than a qualified contractor. The user should only perform the routine maintenance described in the user section of this manual.*

⚠WARNING: *The area around the furnace should be kept free and clear of combustible materials, especially papers and rags.*

⚠WARNING: *Never burn garbage or refuse in your furnace. Never try to ignite oil or gas by tossing burning papers or other material into the furnace.*

⚠CAUTION: *Do not attempt to start the burner when:*

1. *Excess oil or gas has accumulated,*
2. *The furnace is full of vapors,*
3. *The combustion chamber is very hot.*

If one or more of these conditions exist, contact a qualified service person.

⚠CAUTION: *Do not block or obstruct air openings on the furnace casing. Do not block or obstruct air openings communicating within the area in which the furnace is installed.*

⚠CAUTION: *Do not allow the outside air intake to be blocked or obstructed by vegetation, ice, snow, or any other materials.*

⚠WARNING: *Do not use this furnace if any part has been underwater. Immediately call a qualified service agency to inspect the furnace and to replace any part of the electrical or control system which has been underwater.*

⚠WARNING: *Should overheating occur or the fuel supply fail to shut off, shut off the manual fuel supply valve to the furnace before shutting off the electrical supply.*

Should the furnace not operate – note diagnostic code through view port prior to removing doors.

All installations and services must be performed by qualified service personnel.

B. COMPONENT LOCATIONS

The following diagram shows a typical furnace installation and typical position of the components referenced in these instructions.

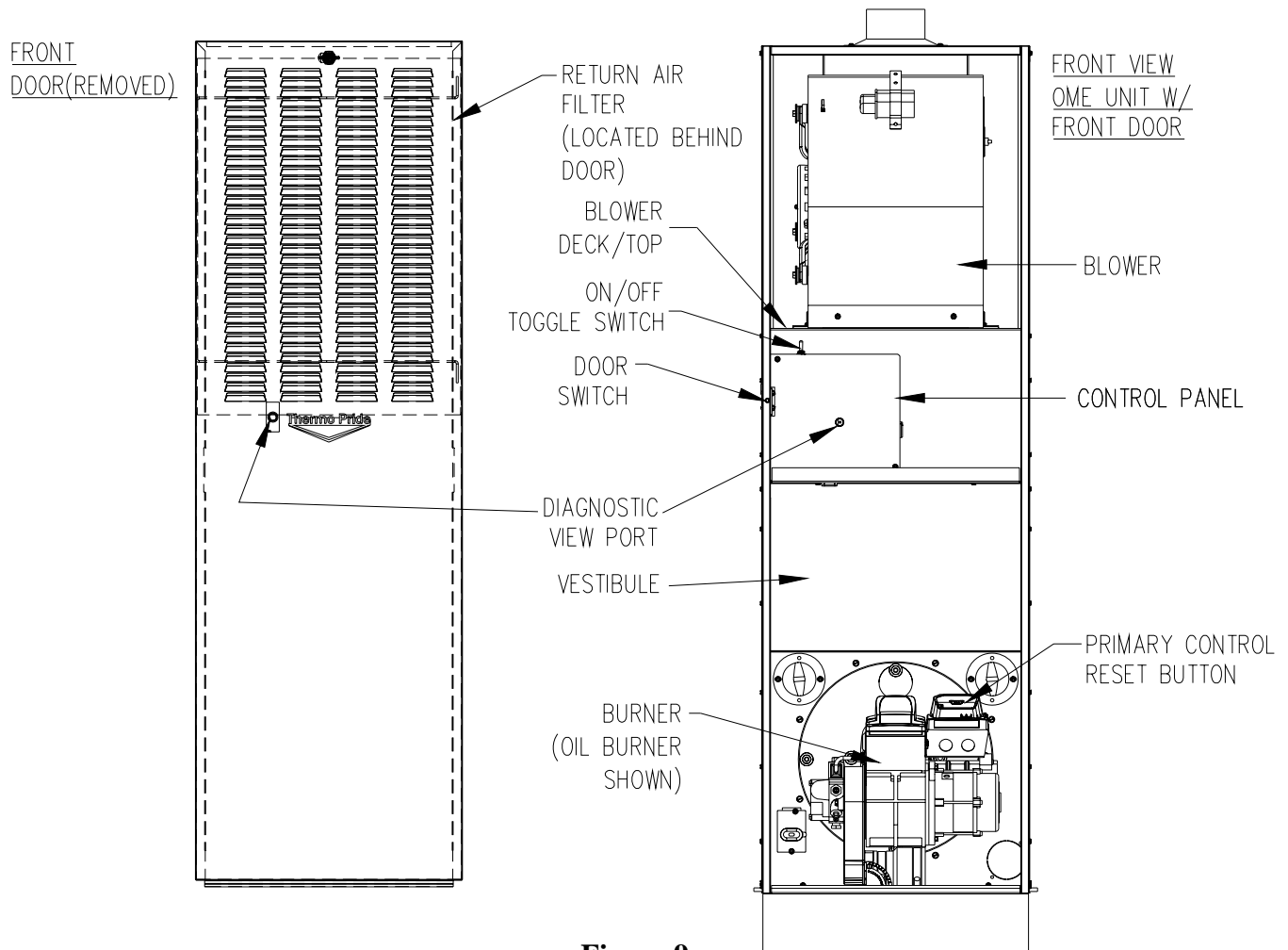

Figure 9.

C. INSPECTION AREAS

IMPORTANT: For safe operation it is the responsibility of the owner and/or user that the burner, chimney/vent pipe, heat exchanger and controls should be inspected every year by a qualified heating contractor.

1. VESTIBULE: The furnace vestibule areas or burner compartment should be inspected by opening the lower front door of the furnace and looking for signs of excessive heat such as discoloration of components, materials damaged from rust or corrosion, soot or carbon build-up.

All installations and services must be performed by qualified service personnel.

2. **EXTERIOR OF FURNACES:** The furnace exterior should be inspected for signs of excessive heat such as discoloration of materials or damage from rust or corrosion.
3. **VENT CONNECTOR:** The furnace vent pipe should be inspected for signs of rust, corrosion pitting, or holes in the pipe. Check for leakage around seams in pipe indicated by soot or condensate streaks.
4. **ROOF JACKS:** The furnace roof jack should be inspected for signs of rust or corrosion, pitting or holes, signs of excessive condensation or moisture leaking from roof jack.

D. FILTER LOCATION AND CLEANING

The air filter should be inspected each month and cleaned when dirty. Cleaning the air filter frequently may prevent airborne contaminants from going through the furnace and depositing in the furnace, duct system and interior of the building.

See Figure 9, in this section, for the location of the return air filter.

E. CONTACT INFORMATION: INSTALLATION / SERVICE

Installed by: _____

Date Installed: _____

Contact Information: _____

All installations and services must be performed by qualified service personnel.

APPENDIX A. REPLACEMENT PARTS LIST

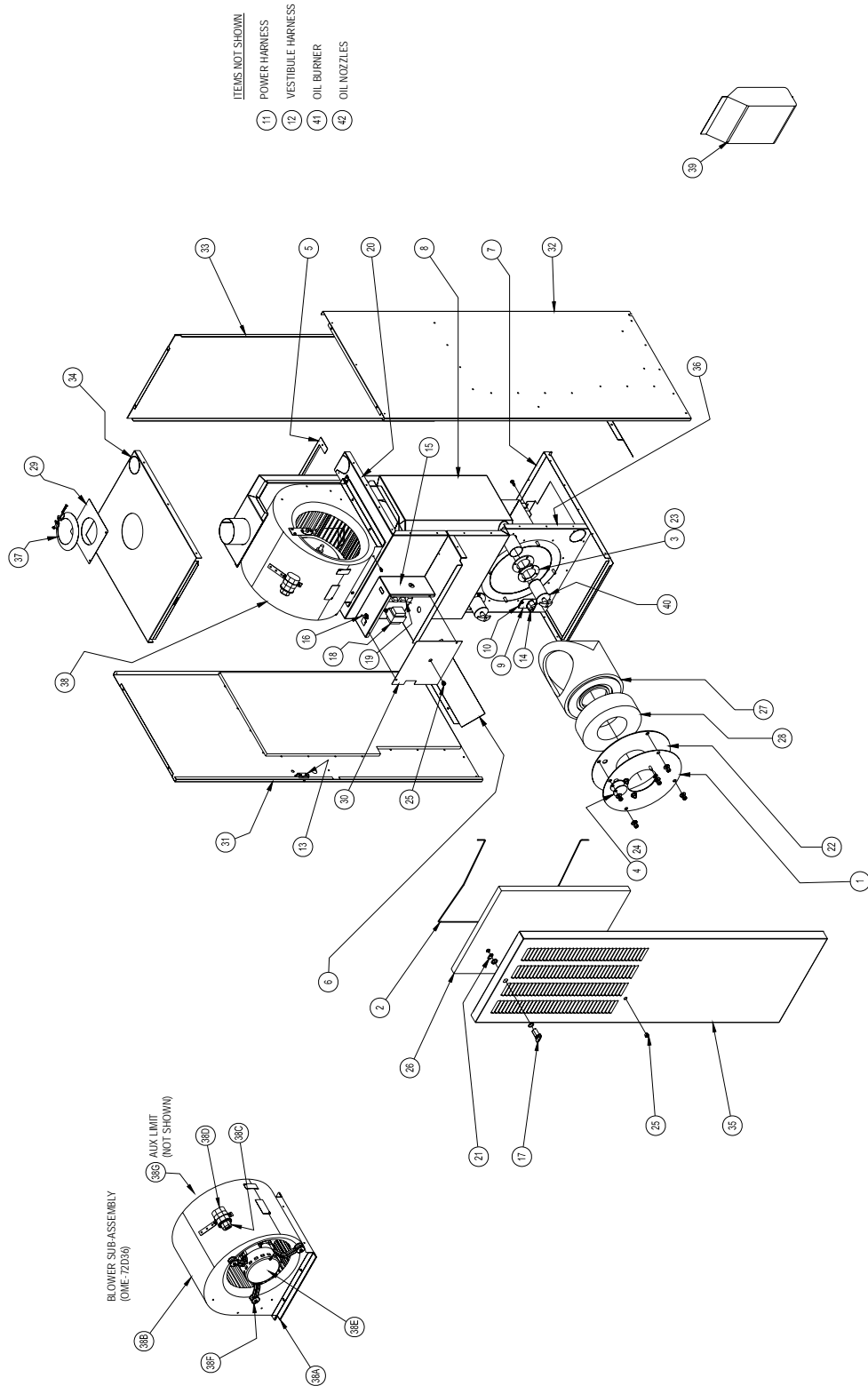

All installations and services must be performed by qualified service personnel.

ITEM	UNIT PARTS DESCRIPTION	OME-72D36		ITEM	UNIT PARTS DESCRIPTION	OME-72D36	
		PART NO.	QTY.			PART NO.	QTY.
1	BURNER MOUNTING PLATE	11891	1	39	PARTS PACKAGE	S00S4187	1
2	FILTER RETAINER	14809	1	39A	INLET ADAPTER	320807	1
3	CLEAN OUT TRIM PLATE	18553	2	39B	FLEX HOSE	19077	1
4	OVER FIRE DRAFT OPENING COVER	18556	1	39C	HOSE CLAMP	300322	1
5	FLUE BLOCK OFF	19071	1	39D	NOZZLE	380279	1
6	AIR SIDE BAFFLE	19075	2	39E	CABLE FITTING	350003	1
7	BASE ASSEMBLY	29060	1	39F	COUPLING	320006	1
8	HEAT EXCHANGER ASSEMBLY	32067	1	39G	BUSHING	320005	1
9	HIGH LIMIT SWITCH	350261	1	40	CLEAN OUT PLUG ASSEMBLY	S00S4456	2
10	LIMIT SHIELD	19076	1	41	OIL BURNER AFG TP1406	380781	1
11	POWER SWITCH HARNESS	350986	1	42	NOZZLES (BECKETT AFG)	380279 (0.50x80*A)	1
12	VESTIBULE WIRE HARNESS	350985	1			380398 (0.60x80*A)	1
13	DOOR INTERLOCK SWITCH	350139	1				
14	INSULATING BOOT	350036	1				
15	CONTROL BOX	19078	1				
16	TOGGLE SWITCH	350136	1				
17	CAM LOCK	320904	1				
18	TRANSFORMER	350464	1				
19	CONTROL BOARD	AOPS8380	1				
20	SEPARATOR / BLOWER PAN	619066	1				
21	CAM	320905	1				
22	BURNER MOUNTING PLATE GASKET	330212	1				
23	TRIM PLATE GASKET	330215	2				
24	DRAFT COVER OPENING GASKET	330343	1				
25	WINDOW PLUG	350248	2				
26	PERMANENT FILTER	370192	1				
27	COMBUSTION CHAMBER, SOFT	380770	1				
28	HEAT SHIELD	380780	1				
29	FLUE TRIM PANEL	612076	1				
30	CONTROL PANEL COVER	618912	1				
31	LEFT SIDE CASING	619055	1				
32	RIGHT SIDE CASING	619056	1				
33	REAR CASING	619057	1				
34	TOP PANEL	619058	1				
35	FRONT DOOR	619059	1				
36	FRONT SEPARATOR PANEL	619065	1				
37	DRAW COLLAR	624100-1	1				
38	BLOWER SUB-ASSEMBLY	S00S4186	1				
38A	BLOWER RETAINER	11637	1				
38B	BLOWER	340042	1				
38C	INSULATING BOOT	350036	1				
38D	CAPACITOR	350073	1				
38E	MOTOR w\ CAPACITOR	AOPS7657	1				
38F	MOTOR MOUNTING BRACKET	AOPS7670	1				
38G	AUX LIMIT SWITCH	350989	1				

Thermo Products, LLC. "PEACE OF MIND" Warranty (Limited) Ten-Year Parts and Transportation Lifetime on Heat Exchanger

Thermo Products, LLC., a Delaware corporation, hereby warrants the Thermo Pride oil and gas fired warm air furnaces manufactured by it to be free from defects in material and workmanship. The warranty is extended to the original owner(s) whose name(s) appear on this certificate and the Warranty Registration Card returned to Thermo Products, LLC. The heat exchanger warranty is also extended to any subsequent owner(s).

1ST-10TH YEAR: During the first 120 months after installation, all parts of the furnace are warranted with the exception of maintenance items which require periodic replacement (i.e. filters, belts, nozzles, electrodes, etc.). The owner may arrange with the original installing dealer or any other qualified dealer of the owner's choice to replace a defective part. Any labor costs involved in furnace diagnosis, service or the removal and replacement of a defective part are the responsibility of the owner. Warranted replacement parts will be shipped with instructions to the dealer on disposition of the defective part. Beyond the fifth year, any transportation costs associated with the replacement of warranted parts are the responsibility of the owner. Beyond the tenth year, only the furnace heat exchanger is covered. The 10-year parts warranty is extended to the original owner only.

BEYOND THE 10TH YEAR: The heat exchanger carries a Limited Lifetime Warranty. If at any time during the warranty period the heat exchanger becomes defective, Thermo Products, LLC. will provide at its option either a replacement heat exchanger or the necessary repair parts on a no charge basis. Any labor costs involved in the diagnosis, repair or the removal and replacement of a heat exchanger are the responsibility of the owner. The owner may arrange with any qualified HVAC dealer for the necessary labor. Beyond the fifth year, any transportation costs associated with the replacement of the complete heat exchanger or the repair parts are the responsibility of the owner. If Thermo Products, LLC. requests the return of the defective heat exchanger after the fifth year, it must be returned by prepaid transportation at the expense of the owner.

THE CONDITIONS OF THIS WARRANTY ARE:

- A. The owner must complete and return the WARRANTY REGISTRATION CARD within ninety (90) days of installation to activate Warranty Coverage. If the completed WARRANTY REGISTRATION CARD is received after the ninety (90) day period, the date of installation will be considered the ninetieth (90th) day after the date the unit was sold to the dealer.
- B. The unit must be operated within its rated capacity as indicated on the rating label and fired with the fuel for which it was designed.
- C. The unit must operate with a duct system designed in accordance with ACCA (Air Conditioning Contractors of America) Manual D (current edition) recommendations and a vent system designed in accordance with current industry venting code(s).
- D. The unit must be installed, set up and maintained in accordance with local and state codes and/or Thermo Products, LLC. installation and operation instructions.
- E. The unit must not be installed in any structure where a corrosive atmosphere exists such as may be found in dry cleaning establishments, laundromats, beauty parlors or industrial buildings without first contacting Thermo Products, LLC. concerning proper application. A corrosive atmosphere is one contaminated by chlorine or fluorine, or any of the halogen group which when entering the combustion area of a furnace cause rapid deterioration of the inner surfaces ultimately leading to heat exchanger failure.
- F. Limit controls which are supplied with the unit and having pre-set maximums must not be modified, altered, or by-passed.
- G. The unit must not be modified and/or operated in any manner other than its design configuration.
- H. No air conditioning or heat pump coil may be installed on the return air side of the furnace.
- I. The unit must remain at its original installation address.
- J. Thermo Products, LLC. shall not be responsible for any failure due to water damage and/or acts of God.

FAILURE TO COMPLY WITH ANY OF ABOVE CONDITIONS WILL VOID ANY AND ALL WARRANTIES LISTED ABOVE.

THIS WARRANTY EXPRESSLY SUPERSEDES ALL OTHER WARRANTIES AND OBLIGATIONS OF THERMO PRODUCTS, LLC. NO PERSON HAS AUTHORITY TO ALTER OR MODIFY THE TERMS OF THIS WARRANTY IN ANY MANNER. THERMO PRODUCTS, LLC. ASSUMES NO LIABILITY FOR CONSEQUENTIAL DAMAGE OF ANY KIND, AND THE PURCHASER BY ACCEPTANCE OF THIS EQUIPMENT ASSUMES ALL LIABILITY FOR THE CONSEQUENCE OF ITS USE OR MISUSE BY THE PURCHASER, HIS EMPLOYEE, OR OTHERS.

Dealers Name _____
Address _____
City, State, Zip _____
Date of Installation _____
Model No. _____ Serial No. _____

Thermo Products, LLC.

P. O. Box 217
North Judson, Indiana 46366
PH. 574-896-2133

Owner(s) _____
Installation Address _____
City, State, Zip _____

Owner's Copy

Retain for Your Records