

# Thermo Pride®



## 13 & 14 SEER AIR HANDLER

### INSTALLATION & SERVICE MANUAL

MODELS: AH2436AE1, AH4260AE1,  
AH2436BE1, AH4260BE1

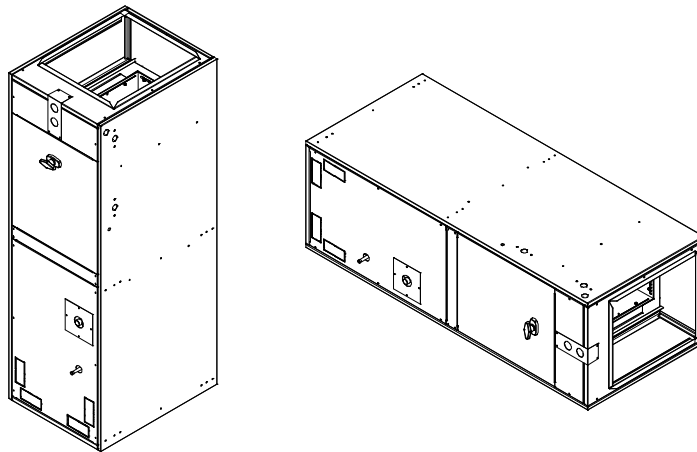

**PLEASE READ THESE INSTRUCTIONS PRIOR TO INSTALLATION AND BEFORE PERFORMING ANY SERVICE OR MAINTENANCE. THESE INSTRUCTIONS MUST BE LEFT WITH THE USER AND SHOULD BE RETAINED FOR FUTURE REFERENCE BY QUALIFIED SERVICE PERSONNEL.**

**⚠WARNING:** *Improper installation, adjustment, alteration, service, or maintenance can cause injury or property damage. Refer to this manual. For assistance or additional information consult a qualified installer, service agency, or manufacturer listed below.*

THERMO PRODUCTS, LLC.  
BOX 237  
DENTON, NC 27239  
PHONE: 800-476-4328



MADE IN USA

MAC-202  
ECN 5577-MA 190924



## TABLE OF CONTENTS

<u>SECTION</u>	<u>BEGINNING PAGE</u>
SAFETY SECTION	1
KNOCKDOWN OF AIR HANDLER	2
REASSEMBLY OF AIR HANDLER	3
SETTING UP THE A-COIL FOR AIR CONDITIONING	4
COUNTERFLOW ORIENTATION	6
INSTALLATION OF HOT WATER COIL	8
BLOWER AIR ADJUSTMENT	9
DUCT SYSTEM	13
DUCT SIZING CHART	14
INDOOR EVAPORATOR COIL	14
TUBING LINE SETS	14
HOW TO MEASURE LIQUID SUB-COOLING	18
MEASURING TEMPERATURE DROP ACROSS THE “A” COIL	19
ELECTRICAL	19
UA ADAPTER CABINET	22
RECOMMENDED SUSPENSION PROCEDURE FOR AH AIR HANDLER	22
ECM TROUBLE SHOOTING	23
TROUBLE SHOOTING CHARTS	26
SEQUENCE OF OPERATION	28
REPLACEMENT PARTS LIST	29

## **SAFETY SECTION**

This page contains various warnings and cautions found throughout this Service and Installation Manual. Please read and comply with the statements on the cover and the statements below.

**⚠WARNING:** *Improper installation, adjustment, alteration, service, or maintenance can cause injury or property damage. Refer to this manual. For assistance or additional information consult a qualified installer, service agency, or manufacturer listed below.*

**⚠CAUTION:** If drilling or screwing into panel or plate is necessary, make certain drill or screw does not penetrate into any part of evaporator coil or hot water coil and cause damage. Personal injury and/or property damage may result.

**⚠WARNING:** Do not use this system if any part has been under water. Immediately call a qualified service agency to inspect the system and to replace any part of the electrical or control system which has been under water.

**⚠WARNING:** The cooling and heating coils must be cleaned by a qualified service person.

**⚠WARNING:** This air handler is not to be used to condition during construction.

**⚠CAUTION:** When testing electrical equipment, always follow standard electrical procedures and precautions.

**⚠CAUTION:** DO NOT wet electronic components during hydronic testing. Wetting electronic components may damage circuitry and cause a hazardous situation. Dry moisture from all leads and terminals if wetting occurs. Wait at least 24 hours for the circuit to fully dry before energizing the system.

**⚠WARNING:** Personal injury or property damage could result from major repair or service of this system by anyone other than a qualified contractor.

**⚠WARNING:** If you do not follow these instructions exactly an unsafe condition may result causing personal injury, loss of life or property damage. Installation and service personnel are required by some states to be licensed. Persons not qualified shall not install this equipment nor interpret these instructions.

All local codes and regulations take precedence over the instructions in this manual and should be followed accordingly. In the absence of local codes, installation must conform with these instructions, regulations of the National Fire Protection Association and provisions of the National Electric Code.

## AIR HANDLER

Each air handler is shipped with an evaporator coil preinstalled. The AH2436A(B)E1 is shipped with a 13U2436AB14 evaporator coil for 2 to 3 ton operation. The AH4260A(B)E1 is shipped with a 13U4848AH20 evaporator coil for 3 to 5 ton operation.

The construction of the air handler permits easy knockdown and reassembly. See Figure A & B.

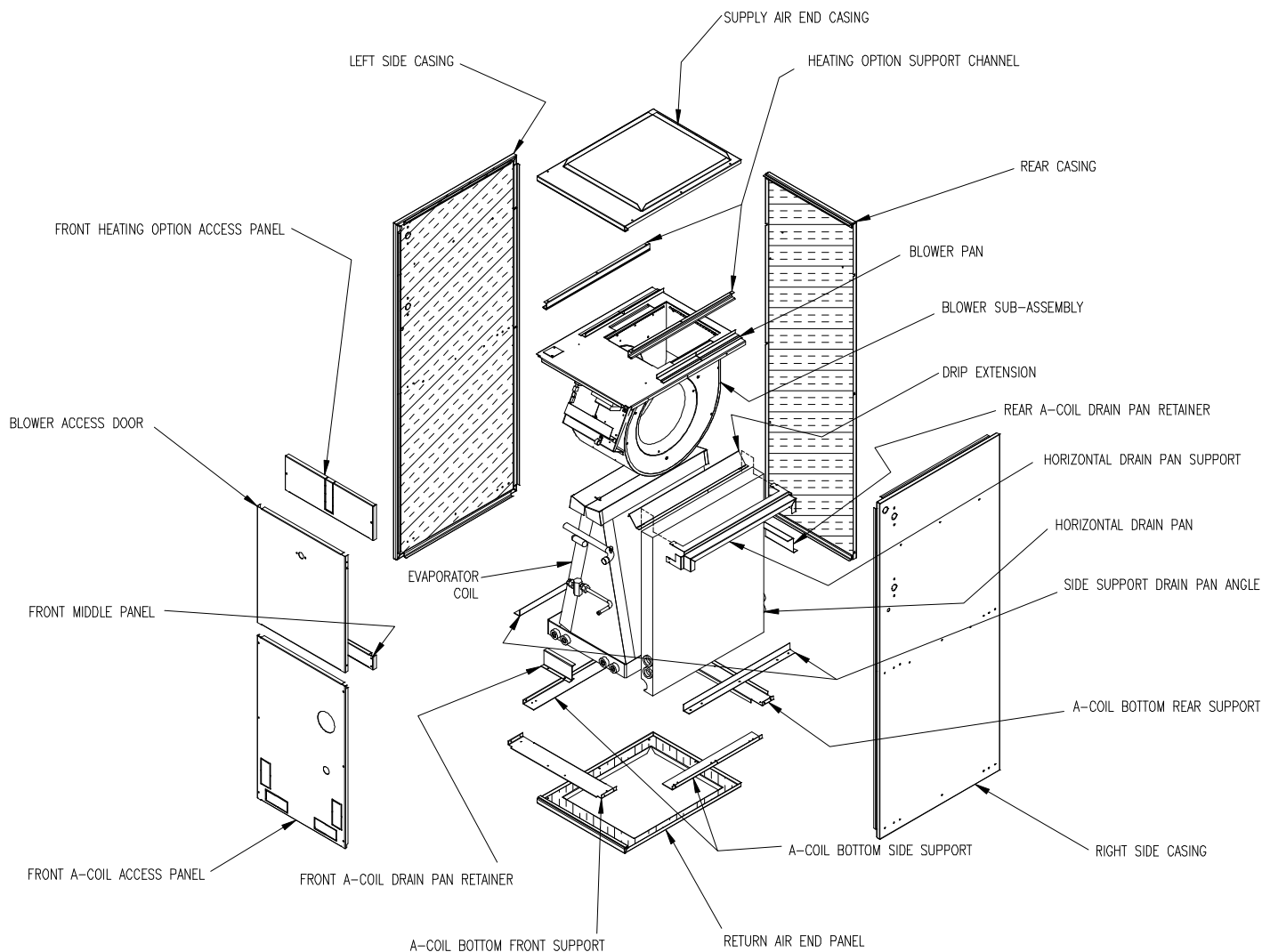

**Figure A.**

### FOLLOW THESE STEPS FOR KNOCKDOWN OF AH2436:

1. Start with unit setting in a vertical position (Figure A).
2. Remove blower access door.
3. Remove screws from front a-coil access panel, front heating option access panel, front middle panel and supply air end casing.
4. Remove the front A-coil drain pan retainer and the horizontal drain pan support shipping screw(s) from the right side casing.
5. Remove the evaporator a-coil assembly.
6. Remove the side support drain pan angles and A-coil bottom front and rear supports.
7. Disconnect power leads and unplug circulation pump connector from the blower control board.

8. Remove the screws that secure the blower assembly to the blower pan and pull blower sub-assembly out the front of the unit.
9. Remove screws that secure the blower pan to the side & rear casings.
10. Push the front edges of the side casings slightly apart and remove the blower pan.
11. Remove screws from the return air end panel and side & rear casings.
12. Remove side & rear casings from the return air end panel.

### **REASSEMBLY OF AH2436**

To reassemble the air handler, reverse steps above starting with number 12.

### **CONVERTING AH2436 FROM “LEFT TO RIGHT” AIRFLOW TO “RIGHT TO LEFT” AIRFLOW:**

- The AH2436 is shipped ready for horizontal “left to right” airflow or vertical operation.
- If horizontal “right to left” airflow is required, follow these steps:

SEE FIGURE 1 FOR STEPS 1 THRU 6

1. Remove front panels from unit, and pull the coil assembly from the housing.
2. Remove the horizontal drain pan, and re-install it to the opposite side of the coil. Note: horizontal drain pan must have drain plugs tightly closed in the rear of the unit.
3. Remove the top plate.
4. Remove the water diverter, and re-install it to the opposite slab.
5. Replace the top plate, and apply sealant to seal any air gaps.
6. Slide the coil assembly w/drain pan back into the housing.

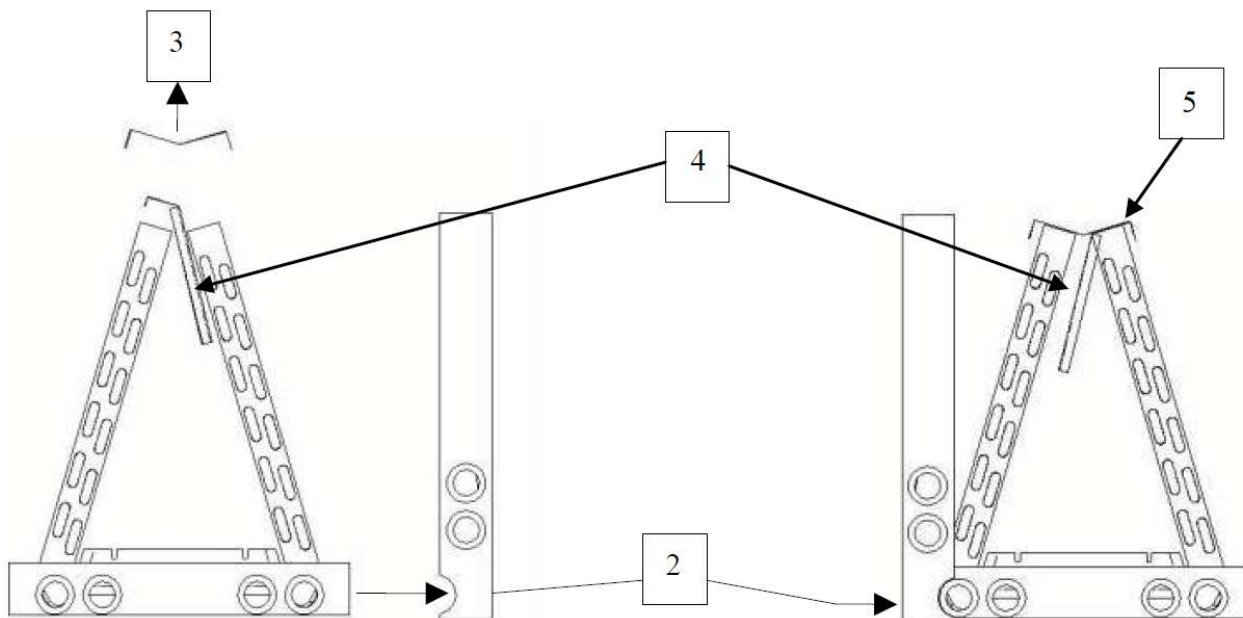
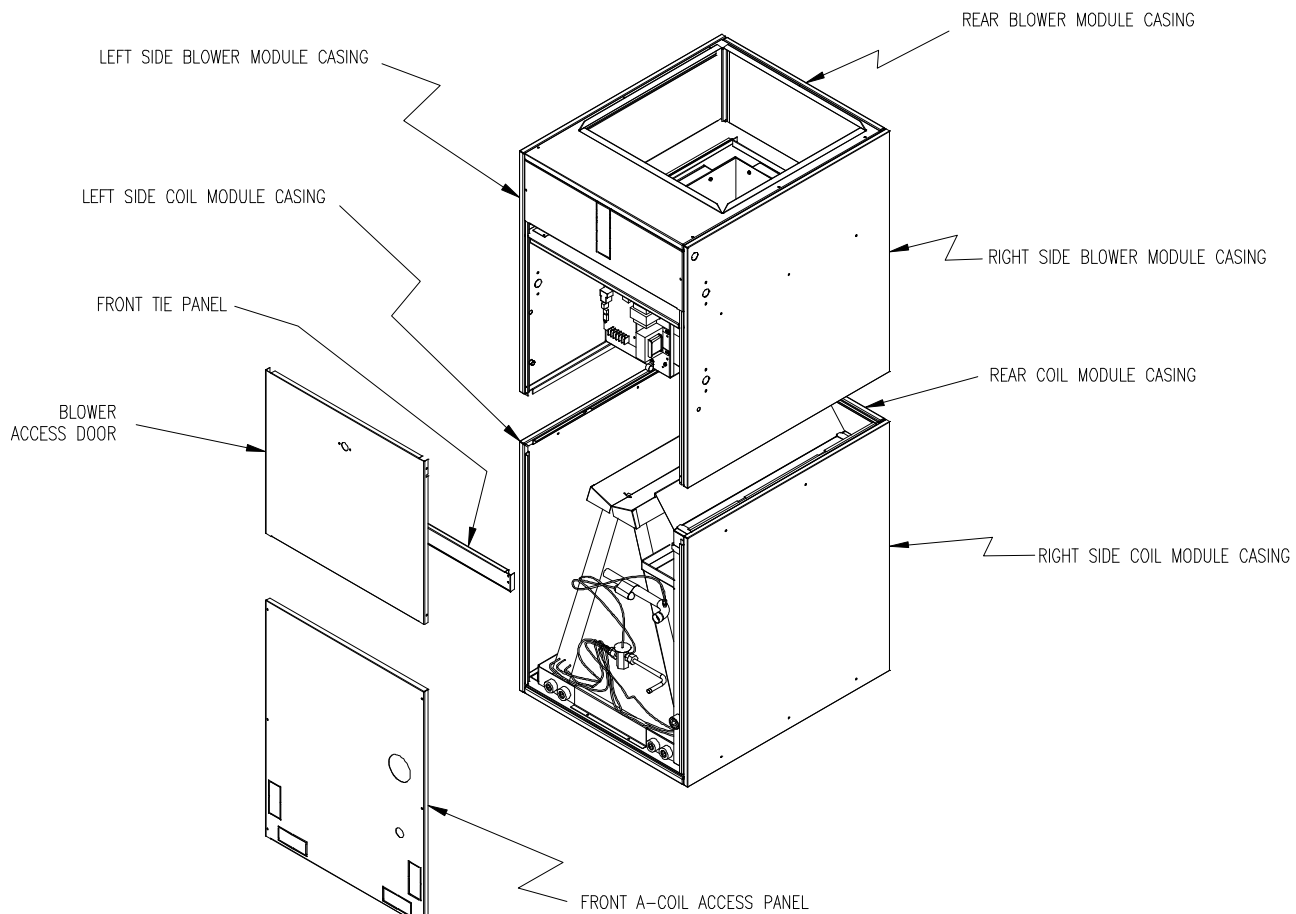

Figure 1.



**Figure B.**

### **FOLLOW THESE STEPS FOR KNOCKDOWN OF AH4260**

1. Start with unit setting in a vertical position (Figure B).
2. Remove the blower access door and front A-coil access panel.
3. Remove front tie panel (four screws).
4. Remove four screws between left/right side blower module casings and left/right side coil module casings.
5. Remove two screws between rear blower module casing and rear coil module casing.
6. Top blower section is now disengaged from bottom coil section. Lift top off of bottom section.
7. If the Air Handler needs to be completely knocked down, follow steps in procedure for the knockdown of the AH2436.

### **REASSEMBLY OF AH4260**

To reassemble the air handler, reverse steps above starting with number 7.

### **SETTING UP THE A-COIL FOR AIR CONDITIONING**

The AH2436 & AH4260 come with the A-coil pre-installed for vertical and left to right horizontal airflow. The A-coil can also be re-positioned for counterflow operation.

**IMPORTANT:** When air handler is installed in attic above a finished ceiling, it is recommended that a safety overflow pan with its own separate drain be installed under the entire unit.

For a right to left horizontal air flow the following steps 1-7 must be followed.  
Otherwise skip to step 8.

### Reversing the horizontal orientation

1. Remove the front a-coil access panel of the air handler.
2. Remove the front a-coil drain pan retainer.
3. Remove the horizontal drain pan support shipping screw(s) from the right side casing.
4. Remove the A-coil assembly and slip the horizontal drain pan assembly off of the right side of the A-coil.
5. Slip the horizontal drain pan assembly onto the left side of the A-coil.
6. Re-install the A-coil assembly into the air handler. The A-coil drain pan should slide under the rear retention clip. The horizontal drain pan assembly should rest against the left side casing insulation and the side support angle.
7. Re-install the front a-coil drain pan retainer in front of the a-coil drain pan.

### For all orientations

8. Cut open the appropriate drain pan drain access hole in the front A-coil access panel.
9. Slip the Suction line grommet panel over the suction line up to the access panel surface.

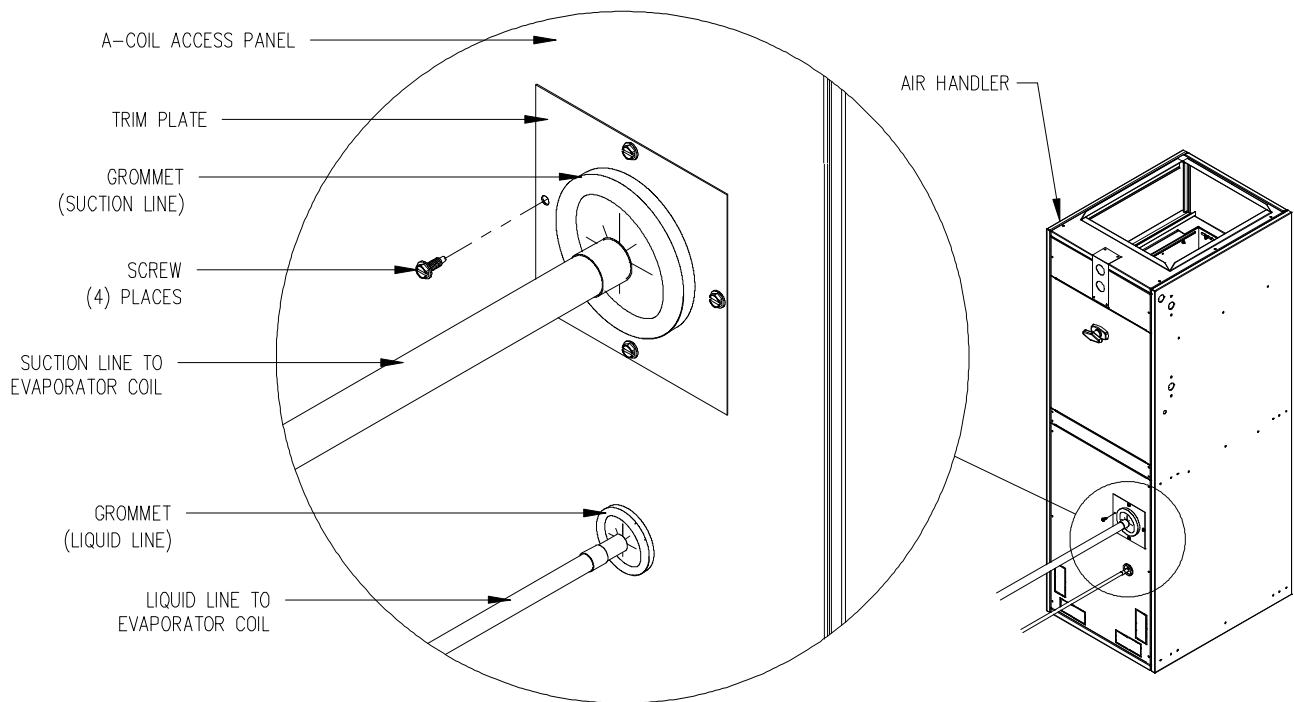

Figure C

11. Make appropriate liquid and suction line connections to coil and braze connections.

**NOTE:** A wet rag makes an excellent heat sink for tubing and grommets.

**⚠CAUTION:** If drilling or screwing into panel of plate is necessary, make certain drill does not penetrate into any part of evaporator coil or hot water coil to avoid personal injury and/or property damage.

13. Position grommet panel on bottom door surface and secure in place with screws. Refer to Figure C.



14. Make appropriate condensate drain connections and seal the access opening.

**For counterflow orientations:**

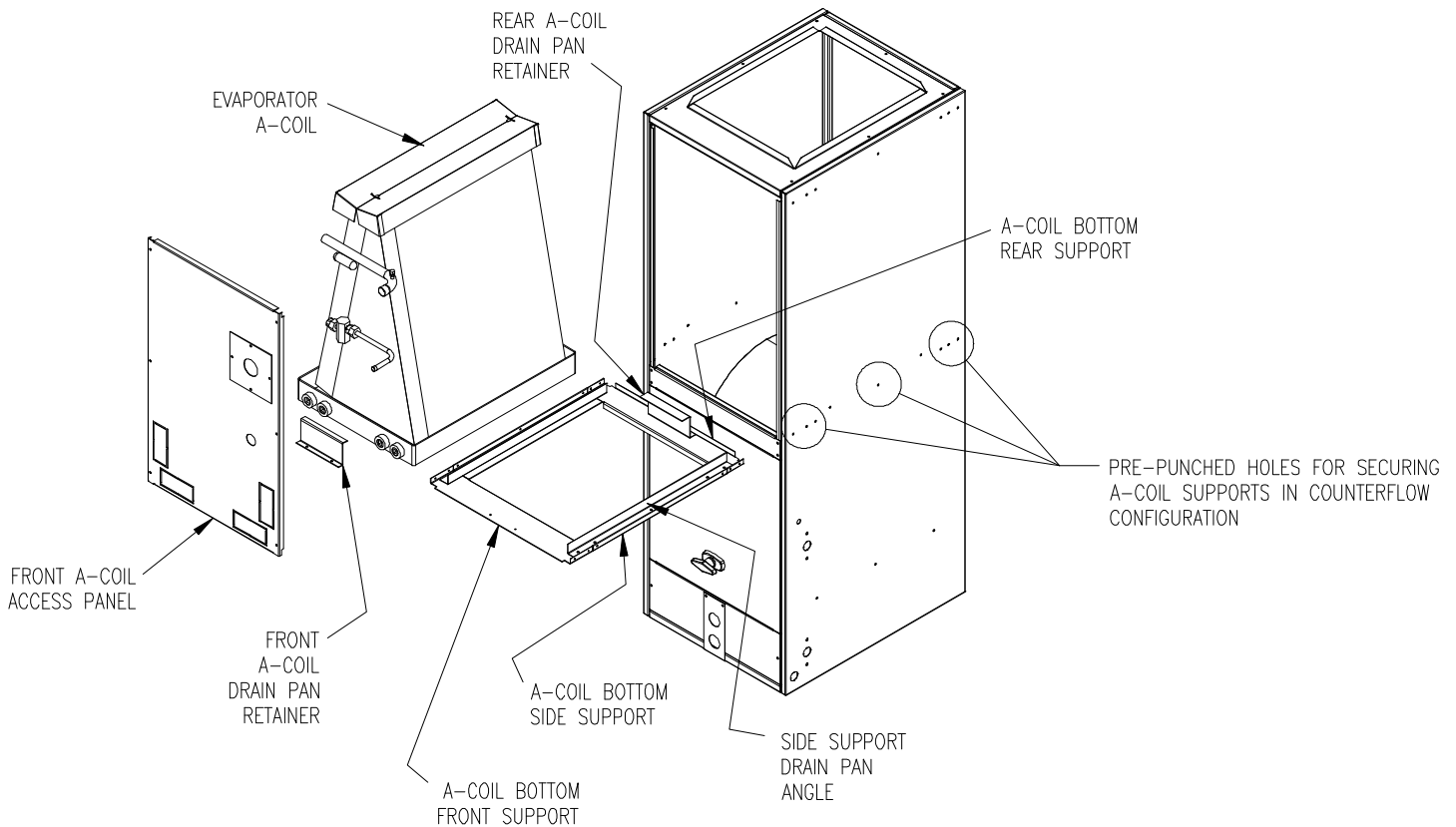

**Figure D**

To convert AH2436 to counterflow:

1. Remove front A-coil access panel
2. Remove front a-coil drain pan retainer and the horizontal drain pan support shipping screws from the right side casing.
3. Remove the A-coil assembly. Slide the horizontal drain pan assembly off of the right side of the A-coil and discard.
4. Remove A-coil bottom front, side, rear supports, side support drain pan angles and rear a-coil drain pan retainer.
5. Turn air handler over.
6. Re-install supports, angles and retainer removed in step 4 in the counterflow configuration using pre punched holes located in the center of the casings.
7. Re-install A-coil and front a-coil drain pan retainer.
8. Re-install front A-coil access panel.

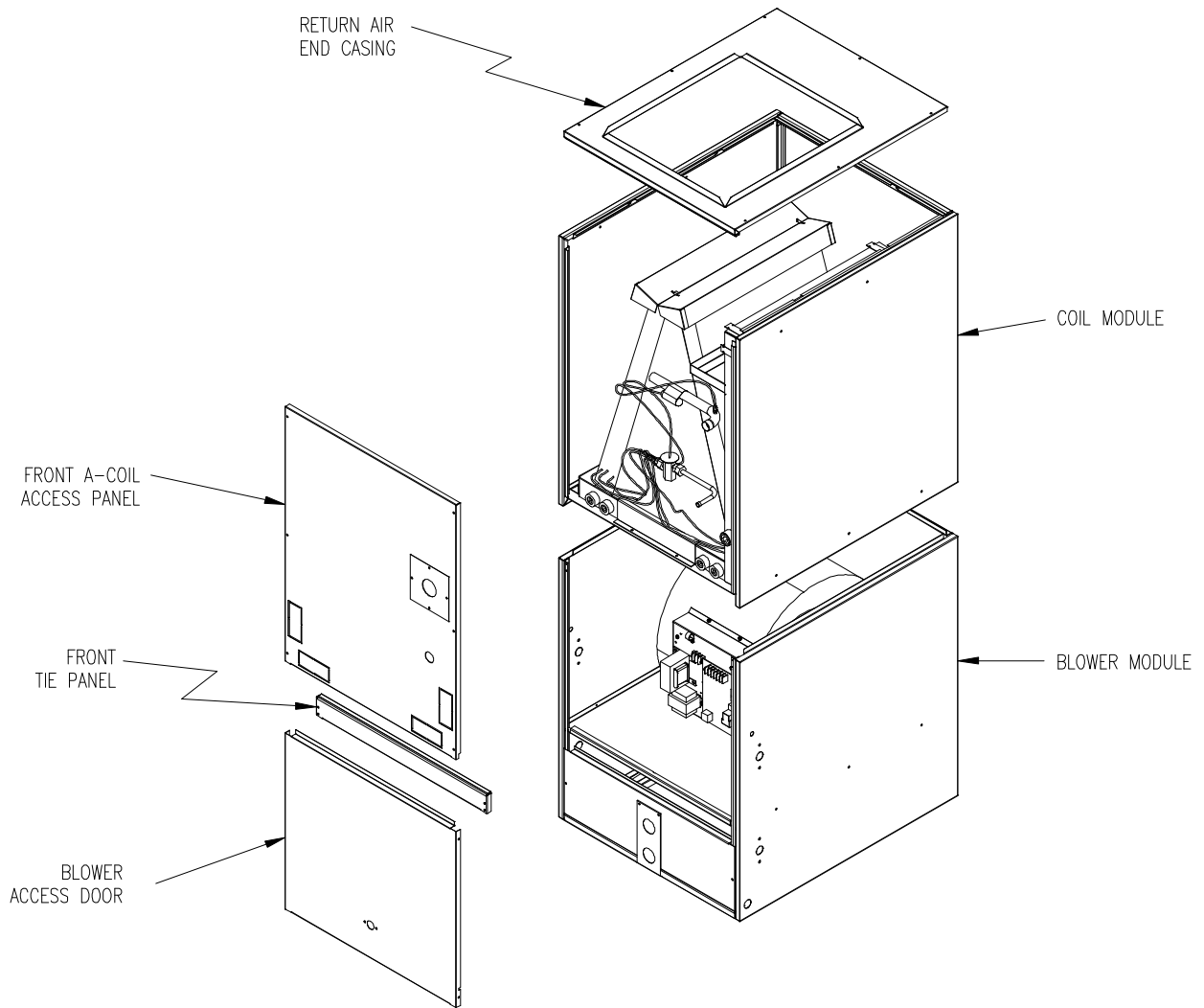

**Figure E**

To convert AH4260 to counterflow:

1. Remove the blower access door and front a-coil access panel.
2. Remove front tie panel (four screws).
3. Remove four screws between left/right side blower module casings and left/right side coil module casings.
4. Remove two screws between rear blower module casing and rear coil module casing.
5. Top blower section is now disengaged from bottom coil section.
6. Lift blower module off of coil module.
7. Turn blower module over.
8. Remove return air end casing from coil module.
9. Place coil module on top of inverted blower module.
10. Re-install return air end casing on top of coil module and secure with screws.
11. Re-install all screws which secure blower module to coil module.
12. Re-install front tie panel.
13. Re-install blower access door and front a-coil access panel.

## INSTALLATION OF THE HOT WATER COIL:

1. Remove top door of air handler.
2. Slide hot water coil's side hanger brackets into coil channel (retaining channel) in the air handler. See Figure F.
3. Push coil into unit until the coil is stopped by the back casing.
4. Cut out appropriate holes in insulation, realign top door and secure into place.
5. Make appropriate hydronic connections to inlet (blower side) and outlet (duct side) of coil and braze into place.
6. Seal connections through panel with duct sealer or equivalent.

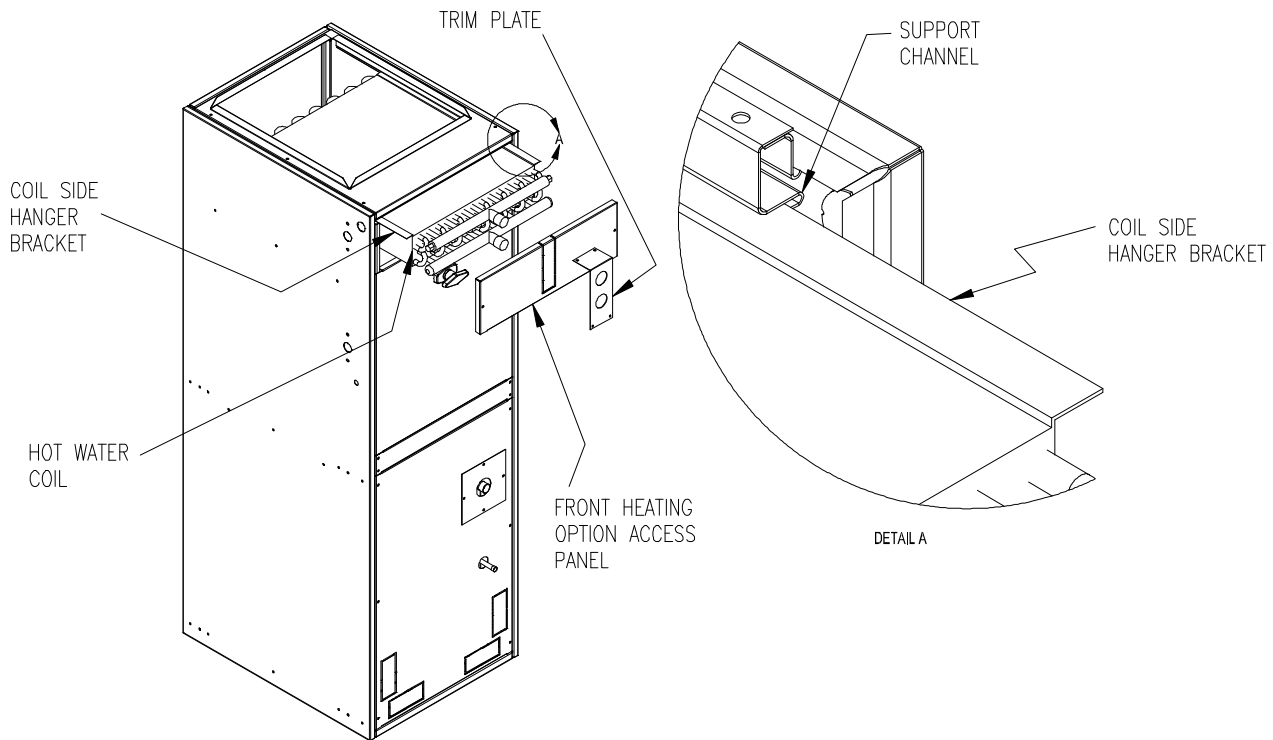

**Figure F**

**⚠CAUTION:** If drilling or screwing into panel or plate is necessary, make certain drill does not penetrate into any part of evaporator coil or hot water coil. Personal injury and/or property damage may result.

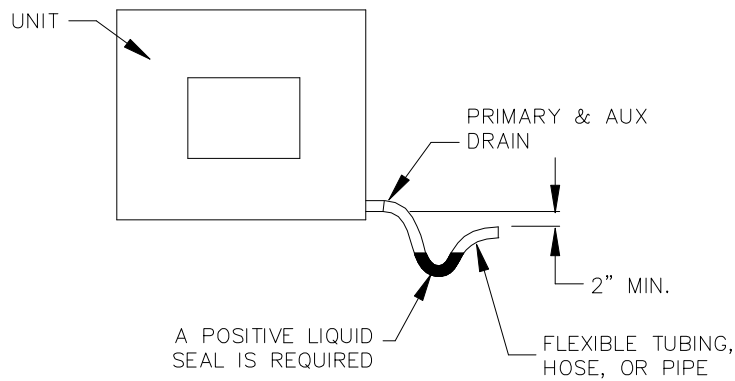
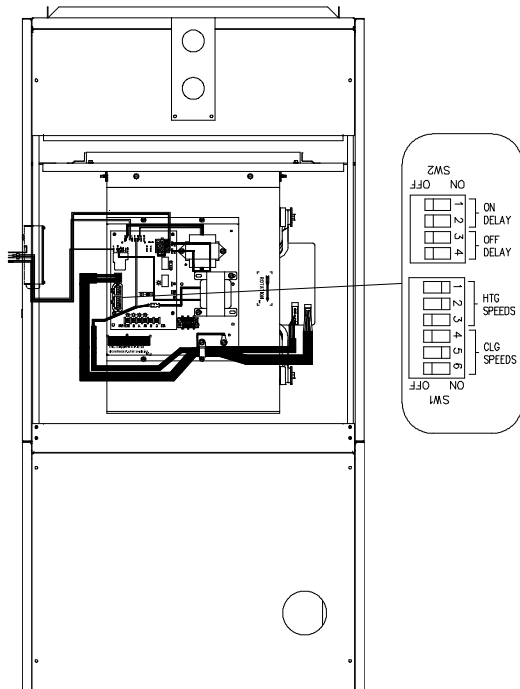

**Figure G**

**NOTE:** Drain lines must be pitched no less than 1/4" per foot away from the air handler.

**BLOWER AIR ADJUSTMENT**

**The ECM blower control must be set in order to establish proper air movement. Use the following steps to do this:**



**Figure H**

1. Identify to tonnage of the condensing unit that will be used.
2. If Hydronic heat is to be used, identify your BTU heat requirements, preferred supply air temperature, water temperature and water flow through the coil in gallons per minute.
3. Locate the blower control board mounted to the front of the blower assembly.
4. Locate the red switch block labeled SW1 for adjusting the Heating and Cooling blower speed.
5. Locate SW2, just below SW1, for adjusting Blower delays.

**BLOWER COOLING SPEEDS**

Refer Table C1 for setting switches 4, 5 & 6 for the A/C sizing.

**Table C1 COOLING SWITCH SETTINGS**

A/C TONS	CFM	AH2436A/BE1 COOL Settings (SW1)			AH4260A/BE1 COOL Settings (SW1)		
		4	5	6	4	5	6
2	800	OFF	OFF	OFF			
2-1/2	1000	<b>ON</b>	OFF	OFF			
3	1200	OFF	<b>ON</b>	OFF	OFF	<b>ON</b>	OFF
3-1/2	1400				<b>ON</b>	<b>ON</b>	OFF
4	1600				OFF	OFF	<b>ON</b>
5	1800				<b>ON</b>	OFF	<b>ON</b>
	2000				OFF	<b>ON</b>	<b>ON</b>
	2200				<b>ON</b>	<b>ON</b>	<b>ON</b>

Shaded cells represent the factory settings

**BLOWER HEATING SPEEDS WITH HYDRONIC COIL**

In the next two pages:

1. Locate the page that refers to the Air Handler to be set up.
2. Find the line(s) on the chart that best represents the water temperature and gallons per minute available.
3. Find the point along the curve that best fits the BTU and Supply Air temperature desired.
4. Read the letter associated with that point and use it to find the switch settings in the table below the chart.

**(The table below the switch settings represent the actual numbers represented by the chart.)**

## HYDRONIC COIL MODEL HC1-B

### AH2436\*E1 Temperature & Heat Values at 140, 160 & 180°F and 3,4,5,6 & 7 gallons per minute at selected speeds

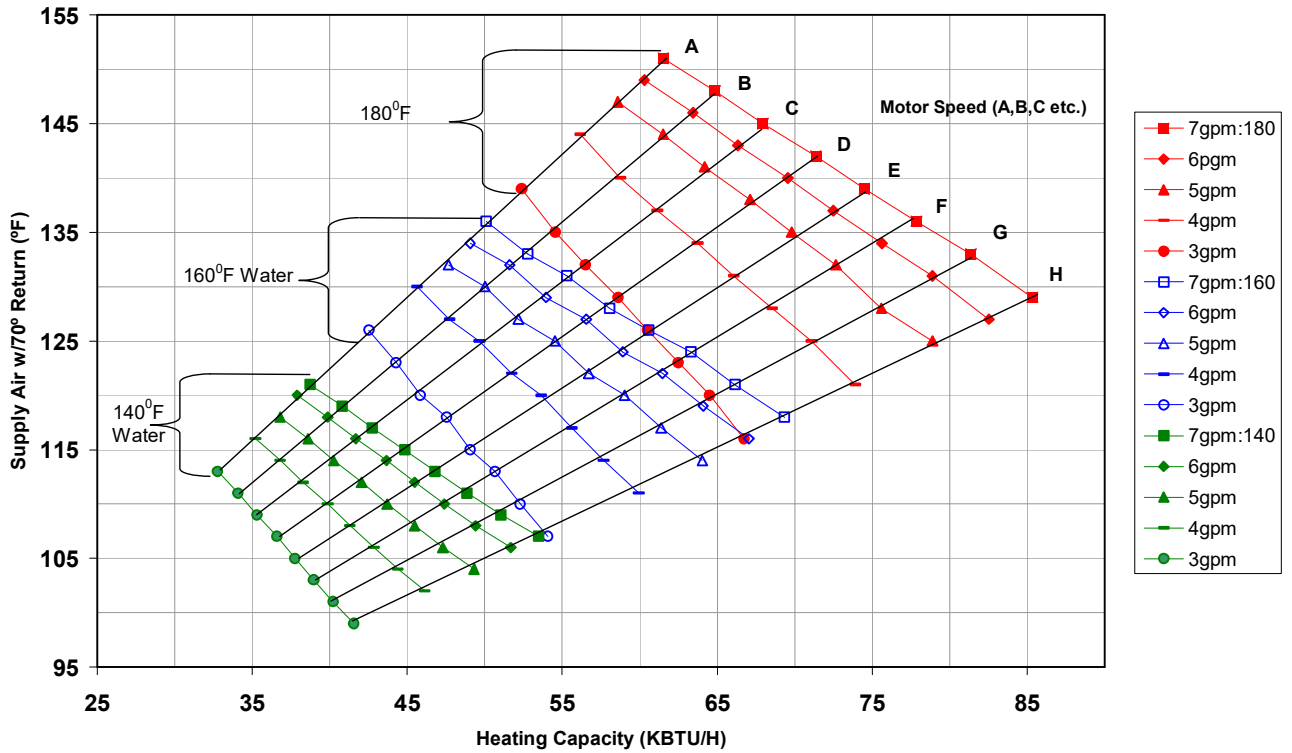

Heat Settings (SW1)				
SPEED	CFM	1	2	3
A	689	OFF	OFF	OFF
B	754	ON	OFF	OFF
C	819	OFF	ON	OFF
D	897	ON	ON	OFF
E	975	OFF	OFF	ON
F	1066	ON	OFF	ON
G	1170	OFF	ON	ON
H	1300	ON	ON	ON

Water Temperature	Flow	Tubeside PD	CFM	Heating Capacity (KBTU/H)							
				689 (A)	754 (B)	819 (C)	897 (D)	975 (E)	1066 (F)	1170 (G)	1300 (H)
180° F	7 gpm	5.42	Supply Air (°F)	151°	148°	145°	142°	139°	136°	133°	129°
			Heat (Kbtu/H)	61517	64858	67946	71362	74504	77871	81378	85332
	6 gpm	4.05	Supply Air (°F)	149°	146°	143°	140°	137°	134°	131°	127°
			Heat (Kbtu/H)	60283	63437	66346	69553	72493	75631	78888	82545
	5 gpm	2.88	Supply Air (°F)	147°	144°	141°	138°	135°	132°	128°	125°
			Heat (Kbtu/H)	58593	61512	64191	67131	69813	72663	75606	78893
4 gpm	1.89	Supply Air (°F)	144°	140°	137°	134°	131°	128°	125°	121°	
		Heat (Kbtu/H)	56163	58766	61139	63727	66073	68549	71090	73907	
3 gpm	1.11	Supply Air (°F)	139°	135°	132°	129°	126°	123°	120°	116°	
		Heat (Kbtu/H)	52393	54554	56507	58615	60509	62490	64505	66717	
160° F	7 gpm	5.54	Supply Air (°F)	136°	133°	131°	128°	126°	124°	121°	118°
			Heat (Kbtu/H)	50092	52795	55294	58057	60597	63317	66151	69343
	6 gpm	4.15	Supply Air (°F)	134°	132°	129°	127°	124°	122°	119°	116°
			Heat (Kbtu/H)	49061	51611	53962	56554	58928	61461	64090	67039
	5 gpm	2.95	Supply Air (°F)	132°	130°	127°	125°	122°	120°	117°	114°
			Heat (Kbtu/H)	47654	50011	52174	54547	56711	59009	61382	64031
4 gpm	1.94	Supply Air (°F)	130°	127°	125°	122°	120°	117°	114°	111°	
		Heat (Kbtu/H)	45639	47738	49652	51738	53629	55624	57670	59939	
3 gpm	1.13	Supply Air (°F)	126°	123°	120°	118°	115°	113°	110°	107°	
		Heat (Kbtu/H)	42530	44272	45845	47544	49069	50664	52286	54068	
140° F	7 gpm	5.67	Supply Air (°F)	121°	119°	117°	115°	113°	111°	109°	107°
			Heat (Kbtu/H)	38730	40806	42723	44842	46788	48872	51041	53484
	6 gpm	4.25	Supply Air (°F)	120°	118°	116°	114°	112°	110°	108°	106°
			Heat (Kbtu/H)	37900	39865	41666	43651	45468	47406	49417	51672
	5 gpm	3.02	Supply Air (°F)	118°	116°	114°	112°	110°	108°	106°	104°
			Heat (Kbtu/H)	36792	38597	40252	42067	43721	45478	47290	49313
4 gpm	1.99	Supply Air (°F)	116°	114°	112°	110°	108°	106°	104°	102°	
		Heat (Kbtu/H)	35200	36806	38268	39862	41305	42828	44390	46121	
3 gpm	1.16	Supply Air (°F)	113°	111°	109°	107°	105°	103°	101°	99°	
		Heat (Kbtu/H)	32760	34090	35291	36588	37751	38968	40206	41565	

**HYDRONIC COIL MODEL HC2-A**  
**AH4260\*E1 Temperature & Heat Values at 140, 160 & 180°F**  
**and 7,8,9 & 10 gallons per minute at selected speeds**

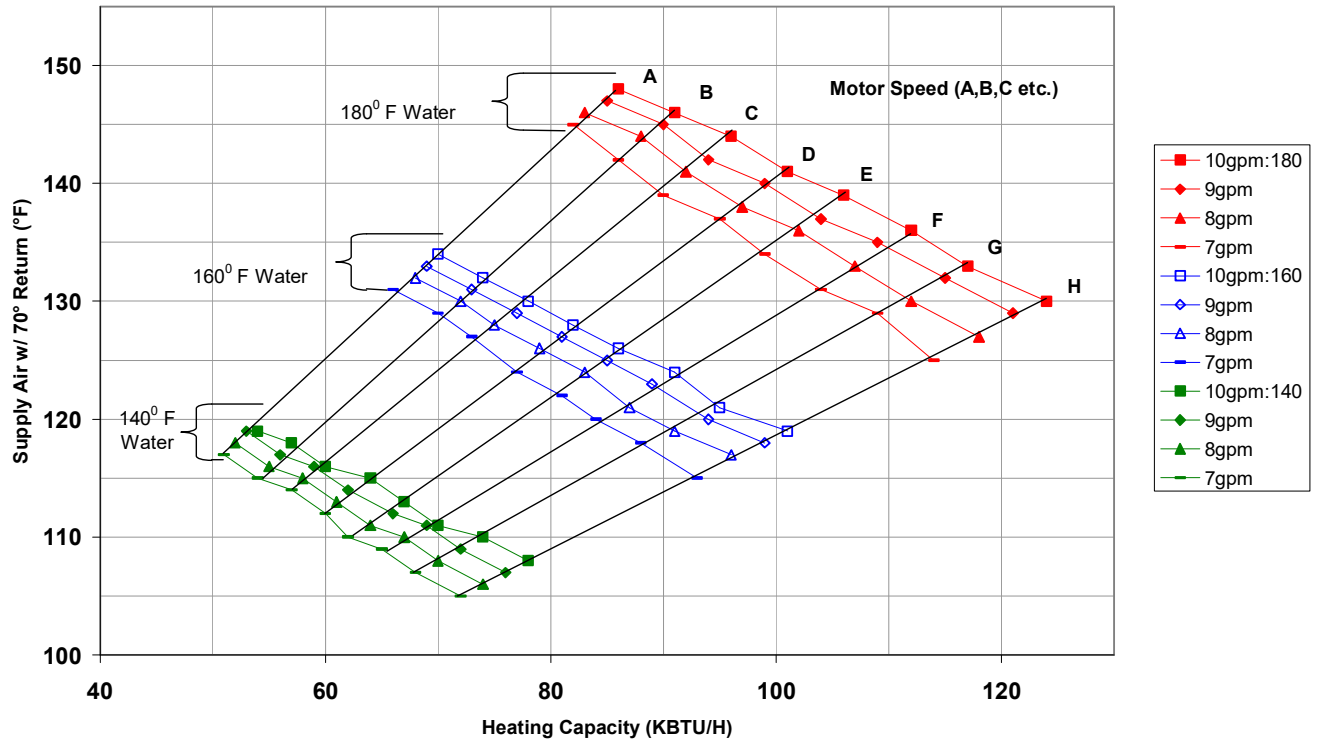

Heat Settings (SW1)				
SPEED	CFM	1	2	3
A	1007	OFF	OFF	OFF
B	1102	ON	OFF	OFF
C	1197	OFF	ON	OFF
D	1311	ON	ON	OFF
E	1425	OFF	OFF	ON
F	1558	ON	OFF	ON
G	1710	OFF	ON	ON
H	1900	ON	ON	ON

Inlet Water Temperature	Flow	Tube Side PD	CFM	1007 (A)	1102 (B)	1197 (C)	1311 (D)	1425 (E)	1558 (F)	1710 (G)	1900 (H)
180°F H <sub>2</sub> O	10 gpm	1.88	Supply Air (°F)	148	146	144	141	139	136	133	130
			Heat (Kbtu/H)	86	91	96	101	106	112	117	124
	9 gpm	1.54	Supply Air (°F)	147	145	142	140	137	135	132	129
			Heat (Kbtu/H)	85	90	94	99	104	109	115	121
	8 gpm	1.23	Supply Air (°F)	146	144	141	138	136	133	130	127
			Heat (Kbtu/H)	83	88	92	97	102	107	112	118
7 gpm	0.95	Supply Air (°F)	145	142	139	137	134	131	129	125	
		Heat (Kbtu/H)	82	86	90	95	99	104	109	114	
160°F H <sub>2</sub> O	10 gpm	1.92	Supply Air (°F)	134	132	130	128	126	124	121	119
			Heat (Kbtu/H)	70	74	78	82	86	91	95	101
	9 gpm	1.57	Supply Air (°F)	133	131	129	127	125	123	120	118
			Heat (Kbtu/H)	69	73	77	81	85	89	94	99
	8 gpm	1.25	Supply Air (°F)	132	130	128	126	124	121	119	117
			Heat (Kbtu/H)	68	72	75	79	83	87	91	96
7 gpm	0.97	Supply Air (°F)	131	129	127	124	122	120	118	115	
		Heat (Kbtu/H)	66	70	73	77	81	84	88	93	
140°F H <sub>2</sub> O	10 gpm	1.95	Supply Air (°F)	119	118	116	115	113	111	110	108
			Heat (Kbtu/H)	54	57	60	64	67	70	74	78
	9 gpm	1.6	Supply Air (°F)	119	117	116	114	112	111	109	107
			Heat (Kbtu/H)	53	56	59	62	66	69	72	76
	8 gpm	1.27	Supply Air (°F)	118	116	115	113	111	110	108	106
			Heat (Kbtu/H)	52	55	58	61	64	67	70	74
7 gpm	0.99	Supply Air (°F)	117	115	114	112	110	109	107	105	
		Heat (Kbtu/H)	51	54	57	60	62	65	68	72	

## **BLOWER TIME DELAY**

In cases where the yellow wires are used to start and stop the hydronic pump, SW2 may be used to delay when the blower is cycled on or off to increase comfort and efficiency.

Use Table D1 to set the switches appropriately

**Table D1: Delays before blower cycles “ON or “OFF”**

SW2 Positions		“ON” Delay	SW2 Positions		“OFF” Delay
1	2	(Seconds)	3	4	(Minutes)
OFF	OFF	30	OFF	OFF	2
ON	OFF	60	ON	OFF	4
OFF	ON	120	OFF	ON	6
ON	ON	480	ON	ON	8

## **DUCT SYSTEM**

The duct system and load sizing calculation should follow the design standards of Air Conditioning Contractors of America (ACCA) - manuals D & J - or the American Society of Heating, Refrigeration and Air Conditioning Engineers, Inc. (ASHRAE) Latest Edition Fundamentals Volume.

To aid you in evaluating existing duct systems quickly, review the chart on Page 14 which shows the CFM capacity for square inch areas, based on .10" wc static pressure (SP) loss on the supply systems.

Each of the system's components (trunk lines, take-offs, runs and register and grill-free areas) must be properly sized and matched together to ensure you are obtaining the air handling capacity of the duct system. A 12x8 duct with a 400 CFM capacity, for example, **MAY NOT** flow 400 CFM if the register(s) to which it connects can only flow a total of 200 CFM.

The air handling capacity **MUST BE EQUAL TO** the supply system at a minimum when sizing the return air duct system. It is recommended to follow design parameters set down by ACCA or ASHRAE on the return air duct systems.



## DUCT SIZES FOR HOMES

### Velocity Approximately 800 Feet Per Minute

CFM	DIA.	SQ.”	RECTANGULAR DUCT DIMENSIONS ... INCHES								
45	4	12.5									
65	5	19.6									
100	6	28							6x6	9x4	
150	7	38							8x6	12x4	
200	8	50							10x6	14x4	
250	9	63						8x8	12x6	18x4	
300	9	63						10x8	14x6	20x4	
400	10	78							12x8	16x6	25x4
500	12	113					10x10	14x8	19x6	30x4	
600	12	113					12x10	16x8	22x6	38x4	
700	12	113					14x10	18x8	26x6		
800	14	154				12x12	15x10	20x8	28x6		
900	14	154				14x12	17x10	22x8	32x6		
1000	16	201				15x12	18x10	24x8	34x6		
1100	16	201			14x14	16x12	20x10	26x8	40x6		
1200	16	201			15x14	17x12	22x10	28x8	42x6		
1300	16	201			16x14	18x12	22x10	30x8	46x6		
1400	18	255			16x14	19x12	24x10	32x8	48x6		
1500	18	255			17x14	20x12	26x10	34x8	50x6		
1600	18	255		16x16	18x14	22x12	26x10	36x8	54x6		
1700	18	255		17x16	20x14	22x12	28x10	38x8	58x6		
1800	18	255		18x16	20x14	24x12	30x10	40x8	62x6		
1900	20	314		18x16	22x14	26x12	32x10	44x8	64x6		
2000	20	314		20x16	22x14	26x12	34x10	46x8			
2200	20	314	18x18	20x16	24x16	28x12	36x10	48x8			

## THE INDOOR EVAPORATOR COIL

1. **EVAPORATOR COIL** is a finned coil through which air in the home is circulated. Heat from the air is transferred to the liquid refrigerant inside the evaporator coil. The coils for use in AH air handlers are in an A-shaped configuration (A Models).
2. **CONDENSATE DRAIN PAN** is attached to the bottom of the evaporator coil to collect water condensed out of the air. Two drain fittings are provided for connection to a convenient drain point.
3. **HORIZONTAL CONDENSATE DRAIN PAN** is attached to the right side of the first one for horizontal left to right air flow. It may be relocated to the left side as well. A drain fitting is provided for connection to a convenient drain point.

## TUBING LINE SETS

1. **SUCTION LINE** is an insulated large copper tube connecting the outlet of the A/C evaporator to the suction inlet of the A/C **CONDENSER**.

2. **LIQUID LINE** is a single small tube connecting the outlet of the A/C condenser to the expansion valve inlet on the A/C evaporator coil.

**TUBING SIZE REFERENCE CHART**

Tube Diameter for Total Line Length						
MODEL	0-50'		50-75'		75-100'	
	Suction	Liquid	Suction	Liquid	Suction	Liquid
HP14241A1, HP14301A1, AC14241E2, AC14301E2	3/4"	3/8"	7/8"	3/8"	1-1/8"	1/2"
HP14361A1, HP14421A1, HP1448xA1, HP1460xA1	7/8"	3/8"	1-1/8"	1/2"	1-1/8"	5/8"
AC14361E2, AC14421E2, AC1448xE2, AC1460xE2	7/8"	1/2"	1-1/8"	1/2"	1-1/8"	5/8"

**NOTES:**

For line lengths over 25' adjust charge accordingly per foot of variation from chart.

- .65 oz. per foot for 3/8" and 3/4" line set
- .674 oz. per foot for 3/8" and 7/8" line set
- .694 oz. per foot for 1/2" and 7/8" line set
- .72 oz. per foot for 1/2" and 1" line set
- .76 oz. per foot for 5/8" and 1-1/8" line set

These charges are to be used in conjunction with a liquid sub-cooling measurement for best performance.

## TUBING INSTALLATION

The compressor oil is constantly pumped through the refrigerant lines in normal operation of an air conditioning system. To ensure proper lubrication of the compressor by avoiding oil accumulation at undesirable points in the system, follow the guidelines listed below:

1. No traps in the suction line are necessary if the outdoor condensing unit is level with the indoor evaporator coil or the indoor evaporator coil is 4 feet or less lower than the outdoor condensing unit. Any horizontal runs of suction line should have minimum 1/2" pitch for every 10 feet of line towards the outdoor condensing unit. See Figure I.

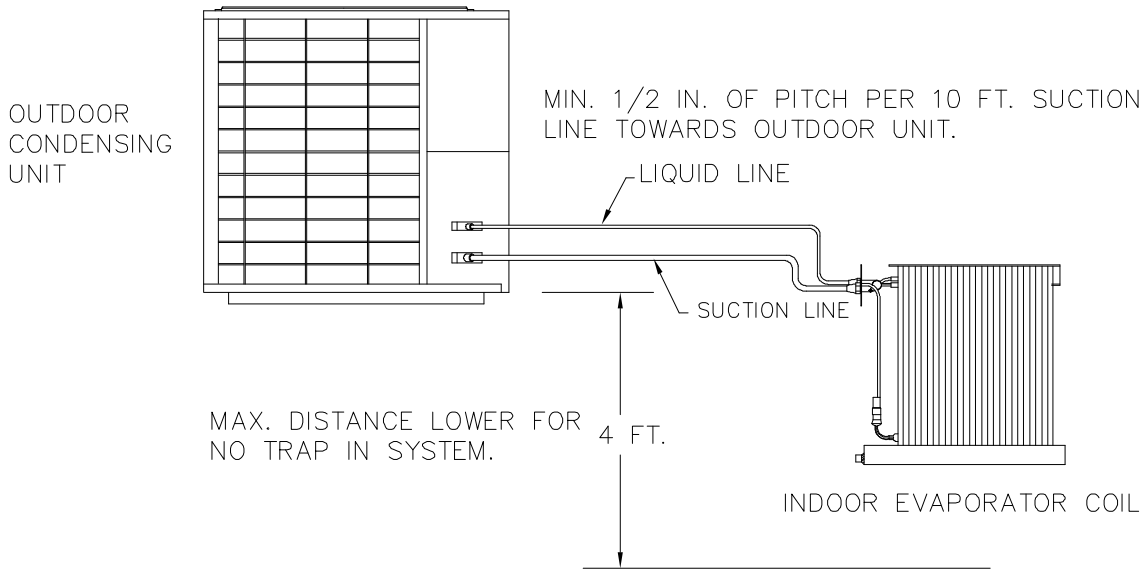

**Figure I.**

2. A trap is necessary in the suction line at the indoor evaporator coil if the indoor evaporator coil is more than 4 feet below the outdoor condensing unit.

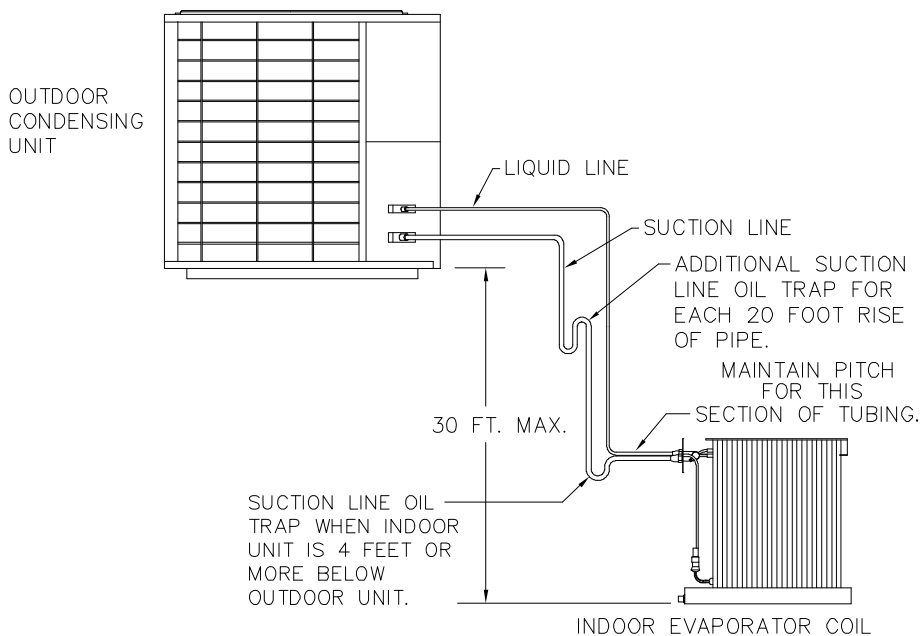

**Figure J.**

**NOTE:** Multiple suction line traps are recommended for longer or multiple suction lines. See Figure J. An inverted trap should be installed on the horizontal suction line near the evaporator coil to prevent liquid flood back to the compressor (See Figure K.) if the indoor evaporator coil is located 10' or more above the condensing unit.

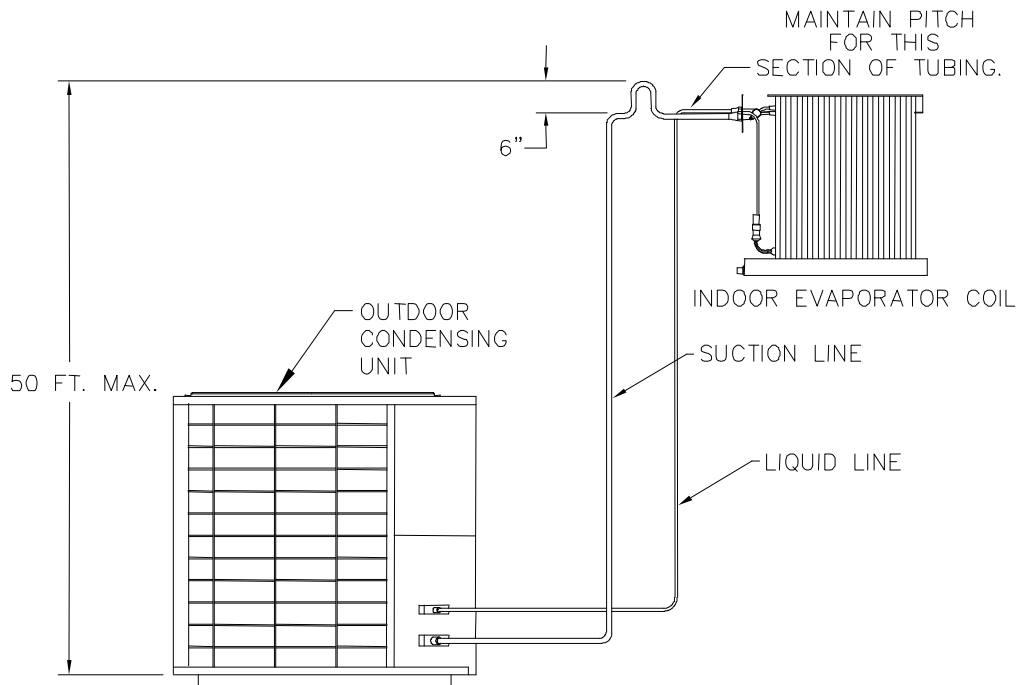

**Figure K.**

A gradual loop in the tubing can be constructed to take up the excess tubing if you find that too much tubing has been brought onto a job. Such a loop **MUST** be kept in a horizontal (flat) plane to avoid trapping the oil.

Refrigerant lines should be inserted into a suitable conduit or raceway when the lines are to be buried between the building and the outdoor condensing unit. The lines must be provided with sufficient protection and support to prevent damage when installed above ground.

When making "on the job" tubing, a solder of 95% tin, 5% antimony or any of the silver solders such as SilFos, Phos-Copper, Easy-Flo 35 or 45, should be used. No attempt will be made here to instruct proper soldering or brazing technique but it is necessary that the installer be properly instructed in accordance with good existing practices.

All joints and fittings must be properly leak tested as per EPA guidelines after "on the job" tubing has been made up. The line set and the evaporator coil must be evacuated to 29.96" Hg (1000 microns) or lower when all joints and fittings are leak free. The service valves on the condenser may then be opened to release the refrigerant to the system. Verify proper system performance. See condensing unit manual for additional performance data.

## **HOW TO MEASURE LIQUID SUB-COOLING**

(NOTE: A good electronic thermometer and accurate liquid pressure gauge with a check valve in the Schraeder fitting are necessary).

**⚠CAUTION:** Failure to use a liquid side hose fitting with a built in check valve may result in personal injury and significant refrigerant loss.

Sub-cooling is measured by taking a temperature and pressure reading. See Figure L. The pressure reading is gauged at the pressure port located on the liquid service valve. The temperature reading is taken at the liquid line at the 3:00 o'clock or 9:00 o'clock position with the liquid line as the center of the clock.

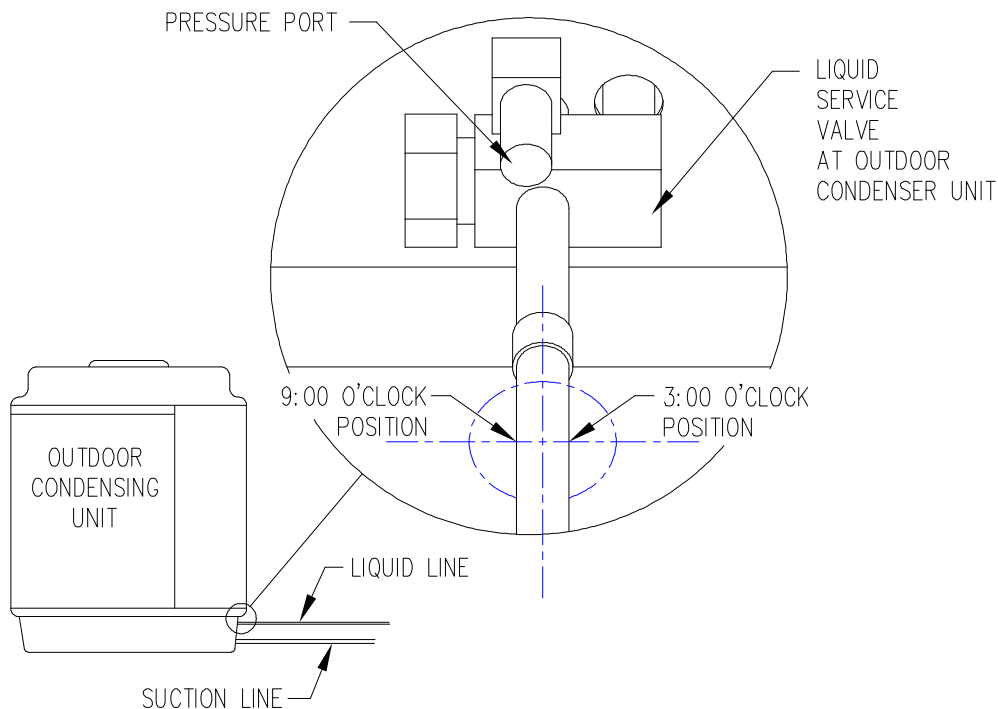

**Figure L.**

Make sure the tube where the temperature is measured is not in direct sunlight.

Read the temperature at the liquid line.

Read the liquid pressure.

Then convert pressure into temperature.

Next, subtract the measured tube temperature from the converted suction temperature.

The end result is the liquid sub-cooling.

### **EXAMPLE:**

Measured Temp = 95°F

Measured Pressure = 211PSI which equates to a 105°F saturation temperature.

(Listed temperature for measured pressure according to R-22 temperature scale on manifold gauge or R-22 section of pressure temperature chart)

The difference equals the degrees superheat = 10°F

A liquid sub-cooling of about 10°F leaving the condenser is good over a wide range of operating conditions for a system with a TXV in the evaporator like the AH2436A/BE1 & AH4260A/BE1.

**MEASURING TEMPERATURE DROP ACROSS THE “A” COIL:**

The temperature drop across the coil should be around 18°F to 23°F difference between inlet and outlet air. This should be measured as close to the air handler as possible, to eliminate duct losses.

**ELECTRICAL**

All wiring must conform to the provisions of local codes or in the absence of local codes with the provisions of the National Electrical Code, ANSI/NFPA No. 70-Latest Edition and this instruction manual. Equivalent type wire must be used if any of the original wire supplied with the unit needs to be replaced.

**NOTE:** Condensing unit is not included in above amp rating.

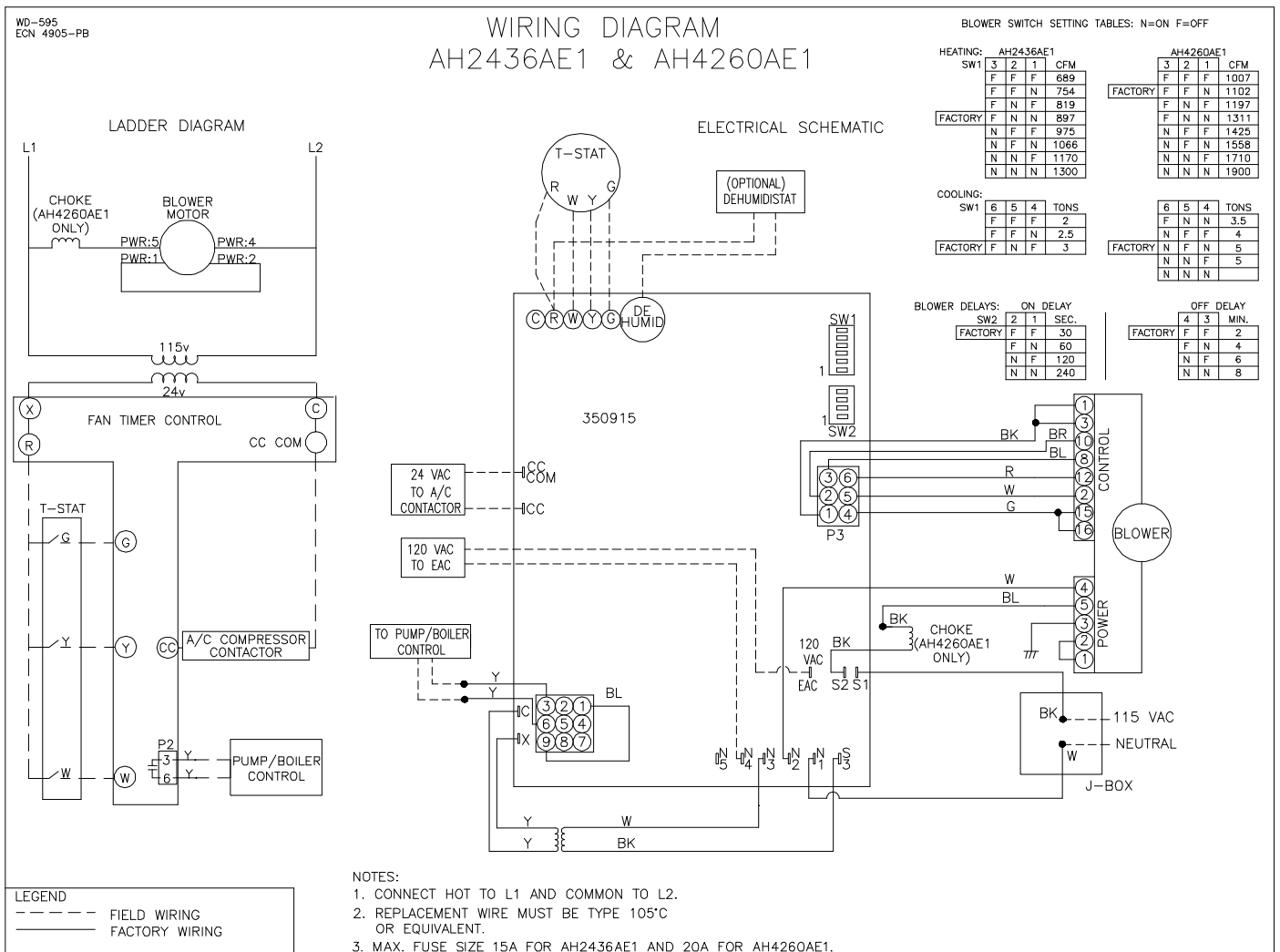

# WIRING DIAGRAM AH2436BE1 & AH4260BE1

BLOWER SWITCH SETTING TABLES: N=ON F=OFF

HEATING: AH2436BE1

SW1	3	2	1	CFM
F	F	F	F	689
F	F	N	F	754
F	N	F	F	819
FACTORY	F	N	N	897
	N	F	F	975
	N	N	F	1066
	N	N	N	1170
	N	N	N	1300

AH4260BE1

3	2	1	CFM	
F	F	F	1007	
F	F	N	1102	
F	N	F	1197	
FACTORY	F	N	N	1311
	N	F	F	1425
	N	N	F	1558
	N	N	N	1710
	N	N	N	1900

COOLING: SW1

6	5	4	TONS
F	F	F	2
F	F	N	2.5
FACTORY	F	N	3

AH4260BE1

6	5	4	TONS
F	N	N	3.5
N	F	F	4
FACTORY	N	F	5
	N	N	5
	N	N	8

OPTIONAL ELECTRIC HEAT KIT (FIELD INSTALLED)

MODELS:  
EH1\*\*A USED WITH AIR HANDLER AH2436BE1.

MODELS:  
EH2\*\*A USED WITH AIR HANDLER AH4260BE1.

NOTES:  
MODEL EH216A DEPICTED IN SCHEMATIC BELOW.

MODEL COMPONENTS WILL DIFFER AS FOLLOWS:

EH104A: (1) SEQUENCER, NO CIRCUIT BREAKER & (1) 4KW HEATER.

EH108A & EH208A: (2) SEQUENCER, NO CIRCUIT BREAKER & (1) 8KW HEATER.

EH212A: (3) SEQUENCER, (2) 40A SP CIRCUIT BREAKER, (2) 20A SP CIRCUIT BREAKER, (1) 8KW HEATER & (1) 4KW HEATER.

EH216A: (4) SEQUENCER, (2) 40A DP CIRCUIT BREAKER, & (2) 8KW HEATER.

### LADDER DIAGRAM

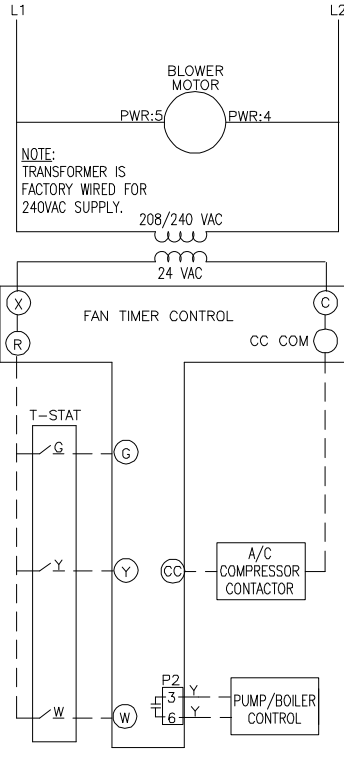

### ELECTRICAL SCHEMATIC

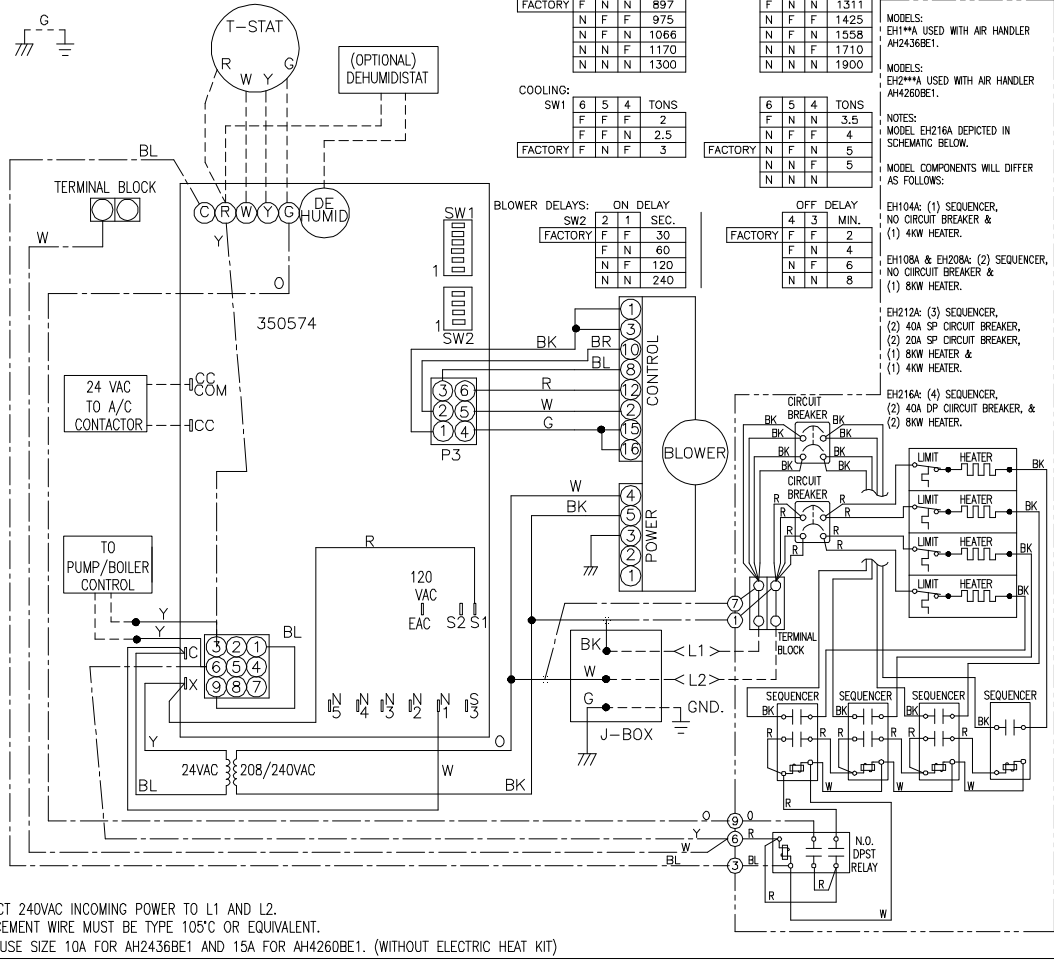

**LEGEND**

--- FIELD WIRING

— FACTORY WIRING

--- ELECTRIC HEAT OPTION FIELD CONNECTION WIRING SUPPLIED WITH KIT.

**NOTES:**

1. CONNECT 240VAC INCOMING POWER TO L1 AND L2.
2. REPLACEMENT WIRE MUST BE TYPE 105°C OR EQUIVALENT.
3. MAX. FUSE SIZE 10A FOR AH2436BE1 AND 15A FOR AH4260BE1. (WITHOUT ELECTRIC HEAT KIT)

Max fuse size for AH2436BE1 w\ EH104A 30A  
Max fuse size for AH4260BE1 w\ EH208A 50A

EH108A 45A  
EH212A 70A

EH216A 85A

The following points must be checked by the installer and/or electrician before the air conditioning system is started:

1. Check every electrical connection of "PUSH-ON" or "SCREW-ON" terminals to ensure it is on tightly on its proper post.
2. Review wiring diagram for proper routing.

## LOW VOLTAGE CONNECTION DIAGRAM FOR AIR HANDLER w\ AIR CONDITIONER & HYDRONIC HEAT

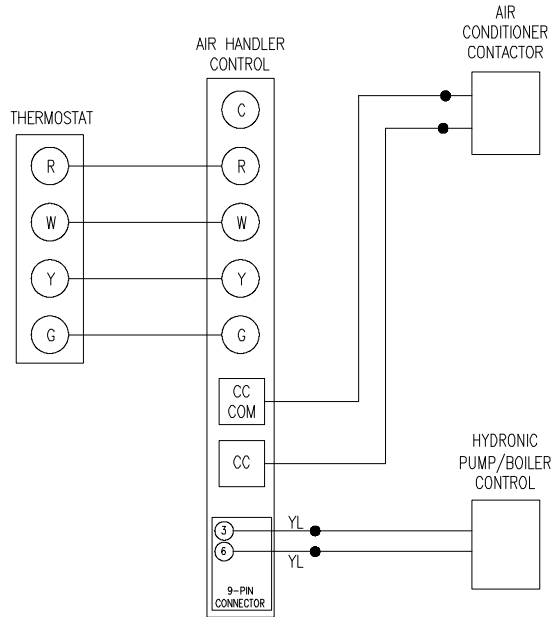

## LOW VOLTAGE CONNECTION DIAGRAM FOR AIR HANDLER w\ HEAT PUMP & HYDRONIC HEAT

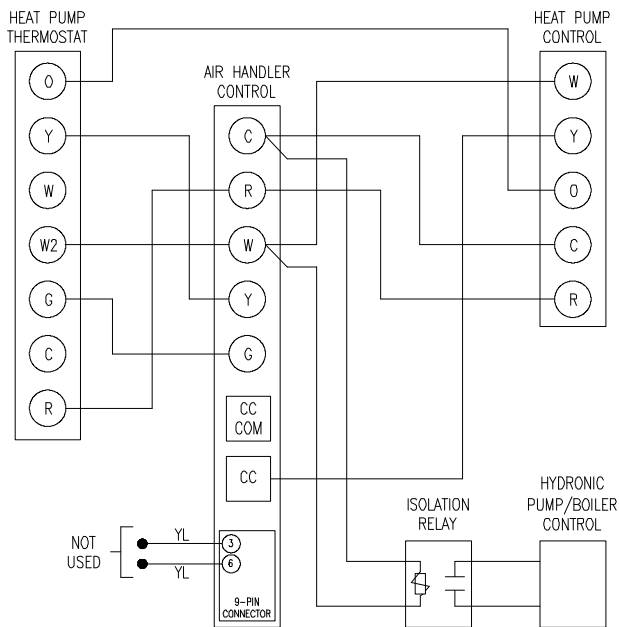

## LOW VOLTAGE CONNECTION DIAGRAM FOR AIR HANDLER w\ HEAT PUMP & ELECTRIC HEAT

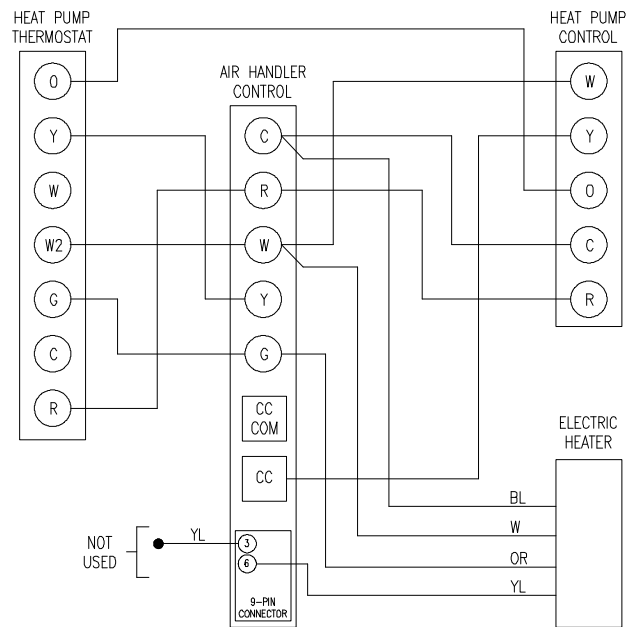



## **UA ADAPTER CABINET**

The UA adapter cabinet is designed to be used in conjunction with the AH AIR HANDLER to allow a free standing (vertical discharge) installation. The UA cabinet is shipped completely assembled and ready for installation.

The return air opening can face either left or right by exchanging the front filter door and rear filter block-off assemblies.

The AH AIR HANDLER is then placed on the UA adapter cabinet, inlet side down.

The UA cabinet is equipped with a permanent washable air filter.

## **AH AIR HANDLER RECOMMENDED SUSPENSION PROCEDURE**

The detail below is the proper and safest way to suspend the AH. These components should be easily found at your local hardware store.

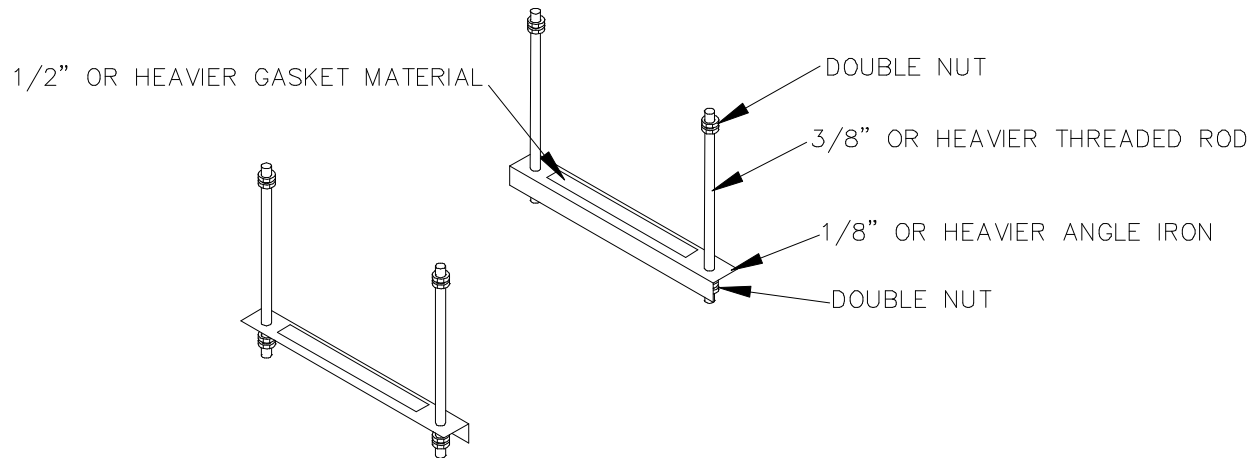

**FIG M**

## ECM TROUBLE SHOOTING DIAGNOSTIC FEATURES

The control board is equipped with 4 green Input Status LEDs and 1 red Board Status LED. These are intended to provide a quick view into furnace performance without requiring a voltmeter.

The green Input Status LEDs are driven by the “Y”, “W”, “G”, and “DEHUM” inputs and are located directly below those inputs. They will light to indicate the presence of these signals.

The red Board Status LED has two functions:

It will light when the board recognizes a valid input signal and will stay lit until all valid signals are removed. This is intended to show that the board is functioning and able to respond to input signals.

### B. GENERAL GUIDELINES TO TROUBLESHOOTING GE ECM – DRIVEN SYSTEMS

**⚠CAUTION:** Disconnect power from unit before removing or replacing connectors, or servicing motor. Wait at least 5 minutes after disconnecting power before opening motor.

SYMPTOM	CAUSE/PROCEDURE
<b>Motor rocks slightly when starting</b>	<ul style="list-style-type: none"> <li>This is normal start-up for ECM</li> </ul>
<b>Motor won't start</b> <ul style="list-style-type: none"> <li>No movement</li> </ul>	<ul style="list-style-type: none"> <li>Check power at motor</li> <li>Check low voltage (24 VAC R to C) at motor</li> <li>Check low voltage connections (G,PWM,W,R,C,) at motor</li> <li>Check for unseated pins in connectors on motor harness</li> <li>Test with a temporary jumper between R – G</li> <li>Check motor for tight shaft</li> <li>Perform motor/control replacement check</li> <li>Run <b>Moisture Check</b></li> </ul>
<ul style="list-style-type: none"> <li>Motor rocks, but won't start</li> </ul>	<ul style="list-style-type: none"> <li>Check for loose or compliant motor mount</li> <li>Make sure blower wheel is tight on shaft</li> <li>Perform motor/control replacement check</li> </ul>
<b>Motor oscillates up &amp; down while being tested off of blower</b>	<ul style="list-style-type: none"> <li>It is normal for motor to oscillate with no load on shaft.</li> </ul>
<b>Motor starts, but runs erratically</b> <ul style="list-style-type: none"> <li>Varies up and down or intermittent</li> </ul>	<ul style="list-style-type: none"> <li>Check line voltage for variation or “sag”</li> <li>Check low voltage connections (G,PWM,W,R,C,) at motor, unseated pins in motor harness connectors</li> <li>Check “Bk” for erratic CFM command (in variable speed applications)</li> <li>Check-out system controls – T’stat?</li> <li>Perform Moisture Check</li> </ul>
<ul style="list-style-type: none"> <li>“Hunts” or “puffs” at high CFM (speed)</li> </ul>	<ul style="list-style-type: none"> <li>Does removing panel or filter reduce “puffing”? <ul style="list-style-type: none"> <li>➢ Reduce restriction</li> <li>➢ Reduce max airflow</li> </ul> </li> </ul>
<ul style="list-style-type: none"> <li>Stays at low CFM despite system call for cool or heat CFM</li> </ul>	<ul style="list-style-type: none"> <li>Check low voltage (T’stat) wires and connections</li> <li>Verify fan is not in delay mode – wait until delay complete</li> <li>“R” missing/not connected at motor</li> </ul>

	<ul style="list-style-type: none"> <li>• Perform motor/control replacement check</li> </ul>
<ul style="list-style-type: none"> <li>• Stays at high CFM</li> </ul>	<ul style="list-style-type: none"> <li>• “R” missing/not connected at motor</li> <li>• Is fan in delay mode? – wait until delay time complete</li> <li>• Perform motor/control replacement check</li> </ul>
<ul style="list-style-type: none"> <li>• Blower won’t shut off</li> </ul>	<ul style="list-style-type: none"> <li>• Current leakage from controls into G,Y or W? Check for Triac switched t’stat or solid state relay</li> </ul>

<b>Excessive noise</b>	<ul style="list-style-type: none"> <li>• Determine if it’s air noise, cabinet, duct or motor noise – interview customer, if necessary</li> </ul>
<ul style="list-style-type: none"> <li>• Noisy blower or cabinet</li> </ul>	<ul style="list-style-type: none"> <li>• Check for loose blower housing, panels, etc.</li> <li>• High static creating high blower speed? <ul style="list-style-type: none"> <li>➤ Check for air whistling thru seams in ducts, cabinets or panels</li> <li>➤ Check for cabinet/duct deformation</li> </ul> </li> </ul>
<ul style="list-style-type: none"> <li>• “Hunts” or “puffs” at high CFM (speed)</li> </ul>	<ul style="list-style-type: none"> <li>• Does removing panel or filter reduce “puffing”? <ul style="list-style-type: none"> <li>➤ Reduce restriction</li> <li>➤ Reduce max airflow</li> </ul> </li> </ul>
<b>Evidence of Moisture</b>	
<ul style="list-style-type: none"> <li>• Motor failure or malfunction has occurred and moisture is present</li> </ul>	<ul style="list-style-type: none"> <li>• Replace motor and perform <b>Moisture Check</b></li> </ul>
<ul style="list-style-type: none"> <li>• Evidence of moisture present inside air mover</li> </ul>	<ul style="list-style-type: none"> <li>• Perform <b>Moisture Check</b></li> </ul>

<b>DO</b>	<b>DON’T</b>
<ul style="list-style-type: none"> <li>• Check-out motor, controls, wiring and connections thoroughly before replacing motor</li> </ul>	<ul style="list-style-type: none"> <li>• Automatically assume the motor is bad.</li> </ul>
<ul style="list-style-type: none"> <li>• Orient connectors down so water can’t get in <ul style="list-style-type: none"> <li>➤ Install “drip loops”</li> </ul> </li> </ul>	<ul style="list-style-type: none"> <li>• Locate connectors above 7 and 4 o’clock positions</li> </ul>
<ul style="list-style-type: none"> <li>• Use authorized motor and control model #'s for replacement</li> </ul>	<ul style="list-style-type: none"> <li>• Replace one motor or control model # with another (unless an authorized replacement)</li> </ul>
<ul style="list-style-type: none"> <li>• Keep static pressure to a minimum: <ul style="list-style-type: none"> <li>➤ Recommend high efficiency, low static filters</li> <li>➤ Recommend keeping filters clean</li> <li>➤ Design ductwork for min static, max comfort</li> <li>➤ Look for and recommend ductwork improvement, where necessary, in replacement</li> </ul> </li> </ul>	<ul style="list-style-type: none"> <li>• Use high pressure drop filters – some have ½” H<sub>2</sub>O drop!</li> <li>• Use restricted returns</li> </ul>
<ul style="list-style-type: none"> <li>• Size the equipment wisely</li> </ul>	<ul style="list-style-type: none"> <li>• Oversize system then compensate with low airflow</li> </ul>
<ul style="list-style-type: none"> <li>• Check orientation before inserting motor connectors</li> </ul>	<ul style="list-style-type: none"> <li>• Plug in power connector backwards</li> <li>• Force plugs</li> </ul>

**Moisture Check**

- Connectors are orientated “down” (or as recommended by equipment manufacturer)
- Arrange harnesses with “drip loop” under motor
- Is condensate drain plugged?
- Check for low airflow (too much latent capacity)
- Check for undercharged condition
- Check and plug leaks in return ducts, cabinet

**Comfort Check**

- Check proper airflow settings
- Low static pressure for lowest noise
- Set low continuous-fan CFM
- T'stat in bad location?

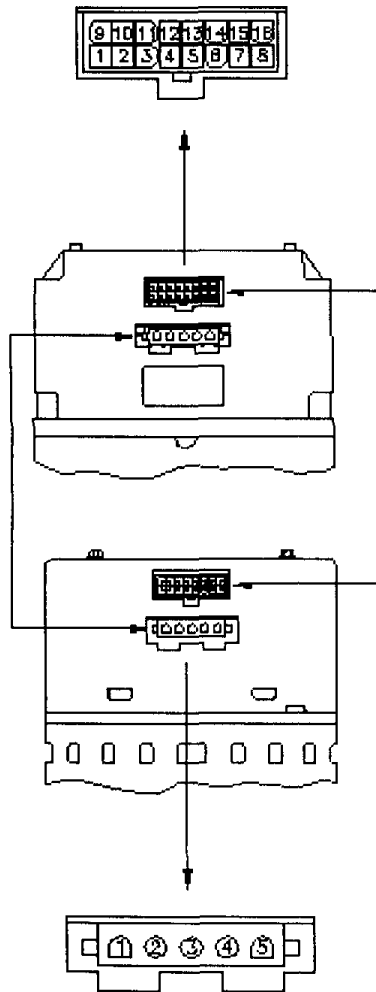

CONTROL CONNECTOR ***	
PIN	DESCRIPTION
1	C1
2	W/W1
3	C2
4	DELAY
5	COOL
6	Y1
7	ADJUST
8	OUT-
9	O
10	BK/PWM
11	HEAT
12	R
13	EM/W2
14	Y/Y2
15	G
16	OUT+

\*\*\* SUGGESTED MATING CONNECTOR  
 HOUSING - AMP 770583-1  
 CONTACT - AMP 770904-1

POWER CONNECTOR *	
PIN	DESCRIPTION
1	JUMPER PIN 1 TO PIN 2 FOR 120VAC LINE INPUT <i>ONLY</i> **
2	
3	CHASSIS GROUND
4	AC LINE 120V or 240V
5	AC LINE 120V or 240V

\* SUGGESTED MATING CONNECTOR  
 HOUSING - AMP 1-480763-1  
 CONTACT - AMP 350537-1

**\*\* WARNING - APPLYING 240VAC LINE INPUT WITH PIN 1 TO PIN 2 JUMPER IN PLACE WILL PERMANENTLY DAMAGE UNIT.**

**Figure N: ECM PIN CONNECTORS**

Troubleshooting table above and Figure N adapted from GE Industrial Systems publication GED-7161C, "Troubleshooting GE ECM – Driven Systems".

# TROUBLESHOOTING CHARTS

THIS GUIDE SHOULD BE USED IN THE CASE OF A STOPPED OR MANFUNCTIONED ECM BLOWER MOTOR. THE FOLLOWING SHOULD HELP ESTABLISH THE TYPE OF MALFUNCTION OR DEVIATION FROM THE NORMAL BLOWER OPERATION.

TO USE THIS DIAGRAM, YOU JUST NEED TO FOLLOW THE INSTRUCTIONS IN THE BOXES.

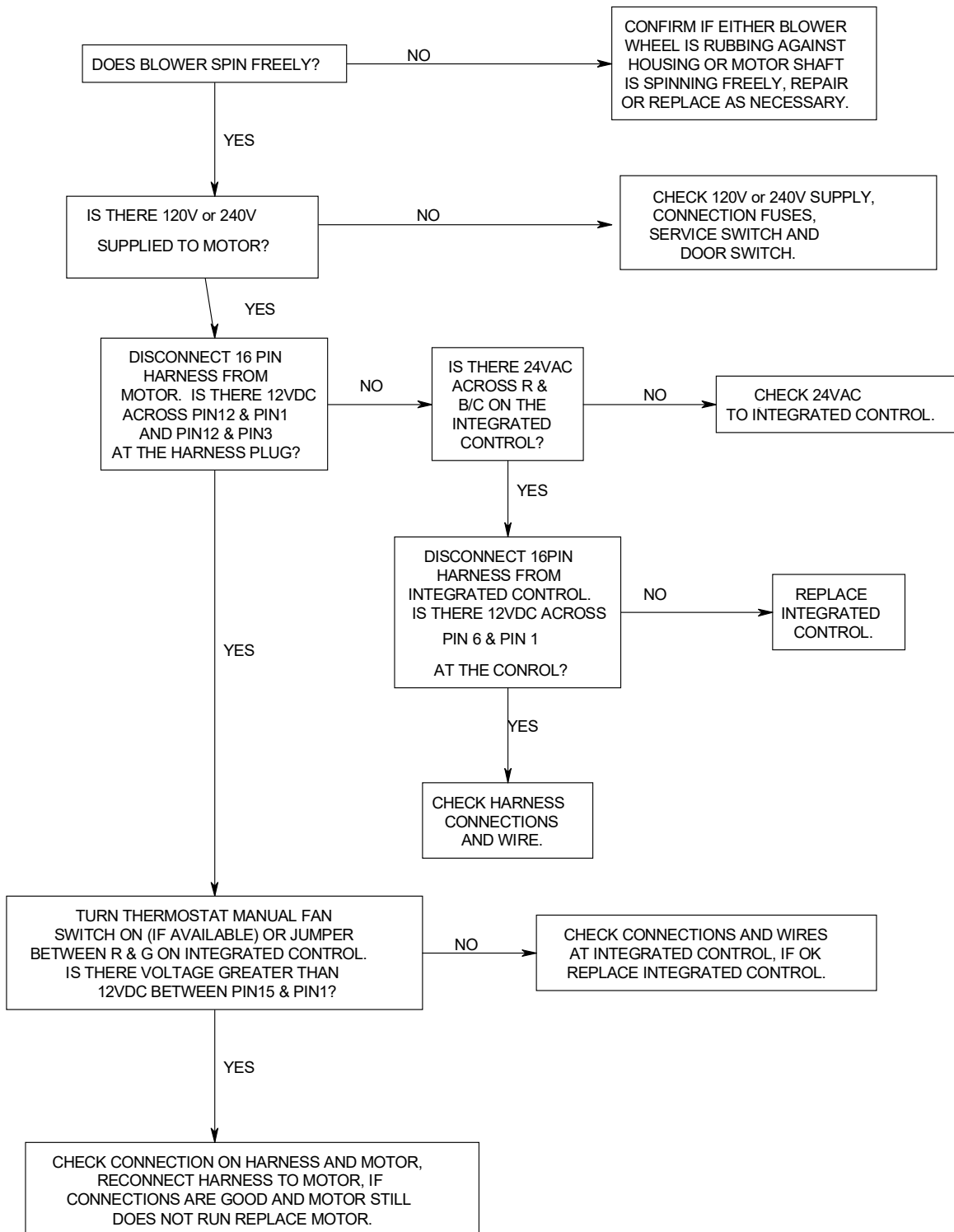

# Sequence of Operation

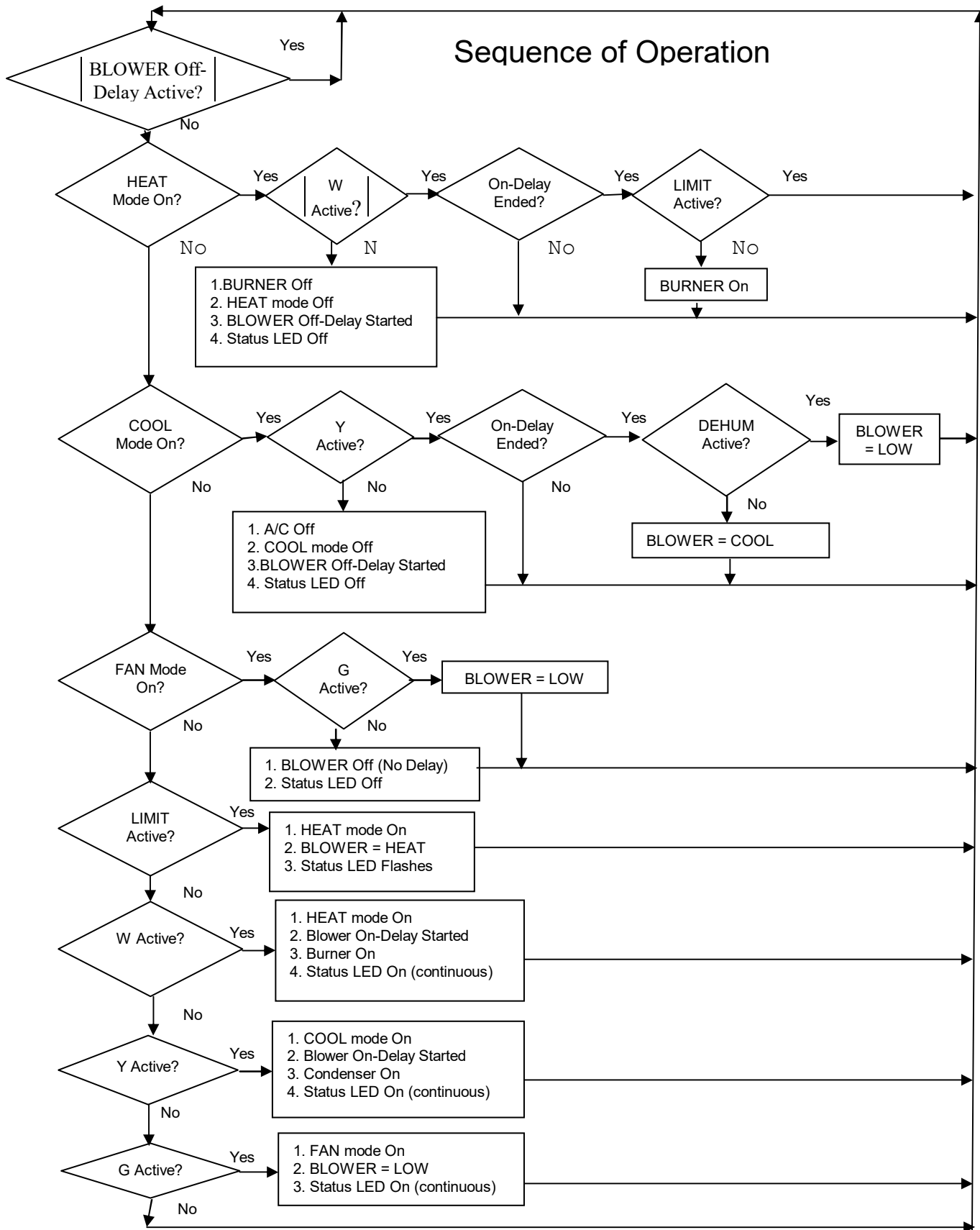

## Sequence of Operation Glossary

### Inputs:

- W- Switched 24vac indicating a Heat call from the thermostat.
- Y - Switched 24vac indicating a Cool call from the thermostat.
- G - Switched 24vac indicating a call for blower operation from the thermostat.
- DEHUM - Switched 24vac indicating a call for Dehumidification from a de-humidistat.

### BLOWER Speeds:

HEAT - The Heating Blower speed selected by positions 1, 2 & 3 of SW1  
(CFM tables on page 11-12)

COOL - The Cooling Blower speed selected by positions 4, 5 & 6 of SW1  
(CFM tables on page 10)

LOW - The LOW Blower speed selected by positions 4, 5 & 6 of SW1  
(CFM tables on page 10)

### **ECM – PSC Replacement for AH2436AE1 or AH4260AE1 only**

In an emergency situation, a defective ECM motor can be replaced with a PSC motor to provide temporary circulating air flow for heating or cooling. This is done by replacing the ECM motor in the motor mounting bracket with a PSC motor of similar Horsepower. Wire the common lead (typically white) of the replacement PSC motor to the neutral (common) terminal on the fan control board (N - 1 through 7). Connect the high-speed replacement PSC motor lead (typically black) to the EAC terminal on the fan control board. The EAC contact is energized with 115VAC any time the control board is calling for fan operation whether in heating or cooling mode. This replacement should be only used in emergency situations and only until a replacement ECM motor can be obtained and reinstalled.

### **ECM – PSC Replacement for AH2436BE1 or AH4260BE1 - call Tech Service.**

# REPLACEMENT PARTS

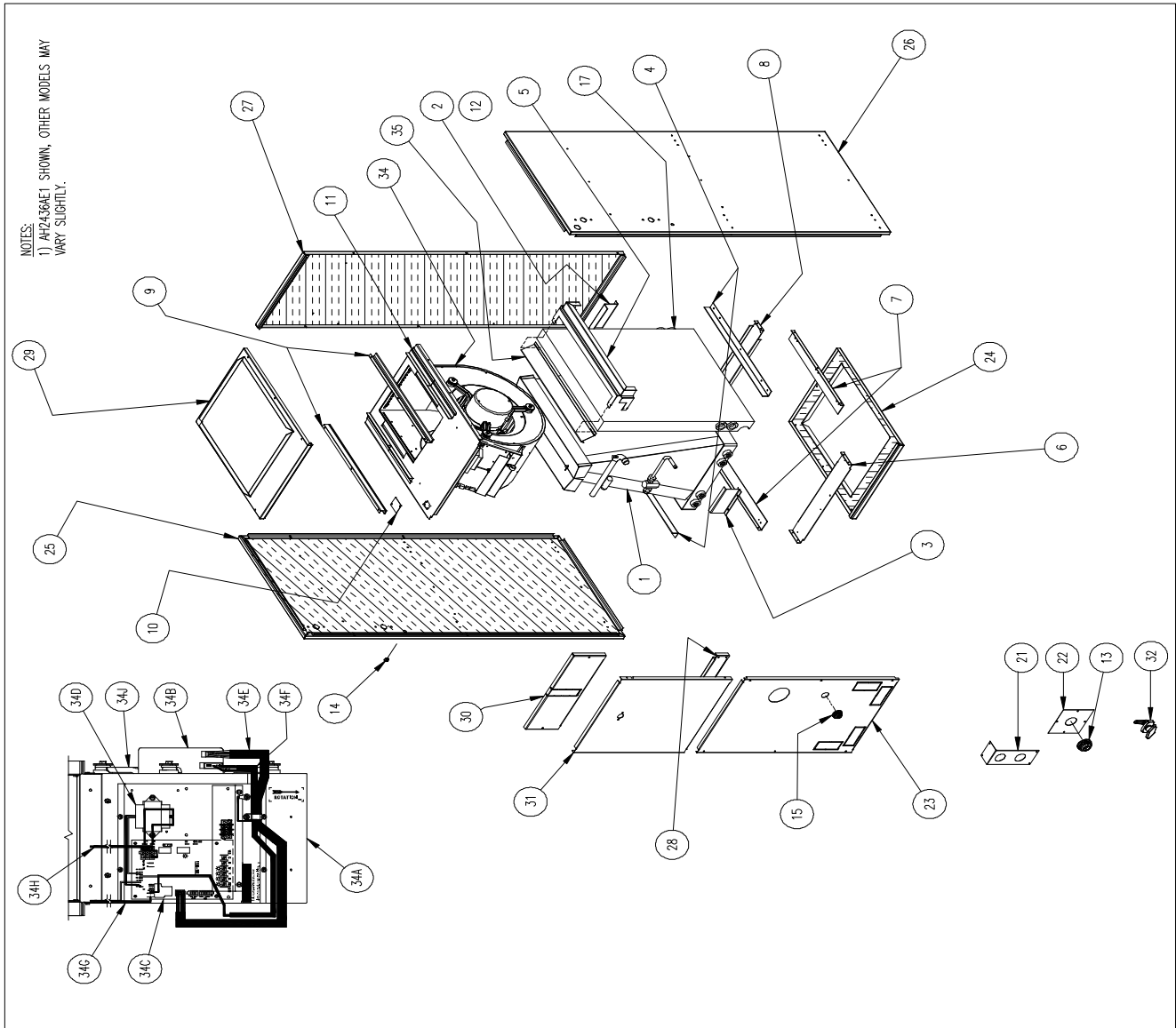

NOTES:  
1) AH2436AE1 SHOWN, OTHER MODELS MAY VARY SLIGHTLY.

ITEM	PARTS DESCRIPTION	AH2436AE1		AH2436BE1	
		PART NO.	QTY.	PART NO.	QTY.
1	COIL, EVAPORATOR ASSEMBLY	AOPS8424	1	AOPS8424	1
2	RETAINER, REAR, A-COIL DRAIN PAN	18790	1	18790	1
3	RETAINER, FRONT, A-COIL DRAIN PAN	18791	1	18791	1
4	ANGLE, SIDE SUPPORT, DRAIN PAN	18792	2	18792	2
5	SUPPORT, HORIZONTAL DRAIN PAN	18793	1	18793	1
6	SUPPORT, A-COIL BOTTOM FRONT	18794	1	18794	1
7	SUPPORT, A-COIL BOTTOM SIDE	18795	2	18795	2
8	SUPPORT, A-COIL BOTTOM REAR	18796	1	18796	1
9	CHANNEL, HEATING OPTION SUPPORT	18799	2	18799	2
10	COVER PLATE, EH WIRE HARNESS PASSAGE	18862	1	18862	1
11	BLOWER PAN	28797	1	28797	1
12	-	-	-	-	-
13	GROMMET, VINYL (LARGE)	350009	1	350009	1
14	BUSHING, HEVCO, 3/8	350018	1	350018	1
15	GROMMET, VINYL (SMALL)	350040	1	350040	1
16	-	-	-	-	-
17	DRAIN PAN, HORIZONTAL	360228	1	360228	1
18	-	-	-	-	-
19	-	-	-	-	-
20	-	-	-	-	-
21	TRIM PLATE	618531-1	1	618531-1	1
22	TRIM PLATE	618656-1	1	618656-1	1
23	PANEL, FRONT, A-COIL ACCESS	618785-1	1	618785-1	1
24	END PANEL, RETURN AIR	618786-1	1	618786-1	1
25	CASING, LEFT SIDE	618787-1	1	618787-1	1
26	CASING, RIGHT SIDE	618788-1	1	618788-1	1
27	CASING, REAR	618789-1	1	618789-1	1
28	PANEL, FRONT MIDDLE	618798-1	1	618798-1	1
29	CASING, SUPPLY AIR END	618800-1	1	618800-1	1
30	PANEL, FRONT, HEATING OPTION ACCESS	618801-1	1	618801-1	1
31	DOOR, BLOWER ACCESS	618802-1	1	618802-1	1
32	DOOR HANDLE PACKAGE	AOPS7578	1	AOPS7578	1
33	INSTR. MANUAL AIR HANDLER	MAC-202	1	MAC-202	1
34	BLOWER SUB-ASSEMBLY	S00S4490	1	S00S4491	1
34A	BLOWER HOUSING ASSEMBLY	S00S4142	1	S00S4142	1
34B	PROGRAMMED ECM MOTOR	AOPS7480	1	AOPS7480	1
34C	CONTROL, ECM	AOP56381	1	350574	1
34D	TRANSFORMER	350464	1	350994	1
34E	MOTOR CONTROL WIRE HARNESS	350334	1	350334	1
34F	MOTOR POWER WIRE HARNESS	350333	1	350333	1
34G	POWER WIRE HARNESS	350929	1	-	-
34H	CIRCULATION PUMP WIRE HARNESS	350930	1	350930	1
34J	MOTOR BRACKET	AOPS7670	1	AOPS7670	1
35	DRIP EXTENSION	12100	1	12100	1



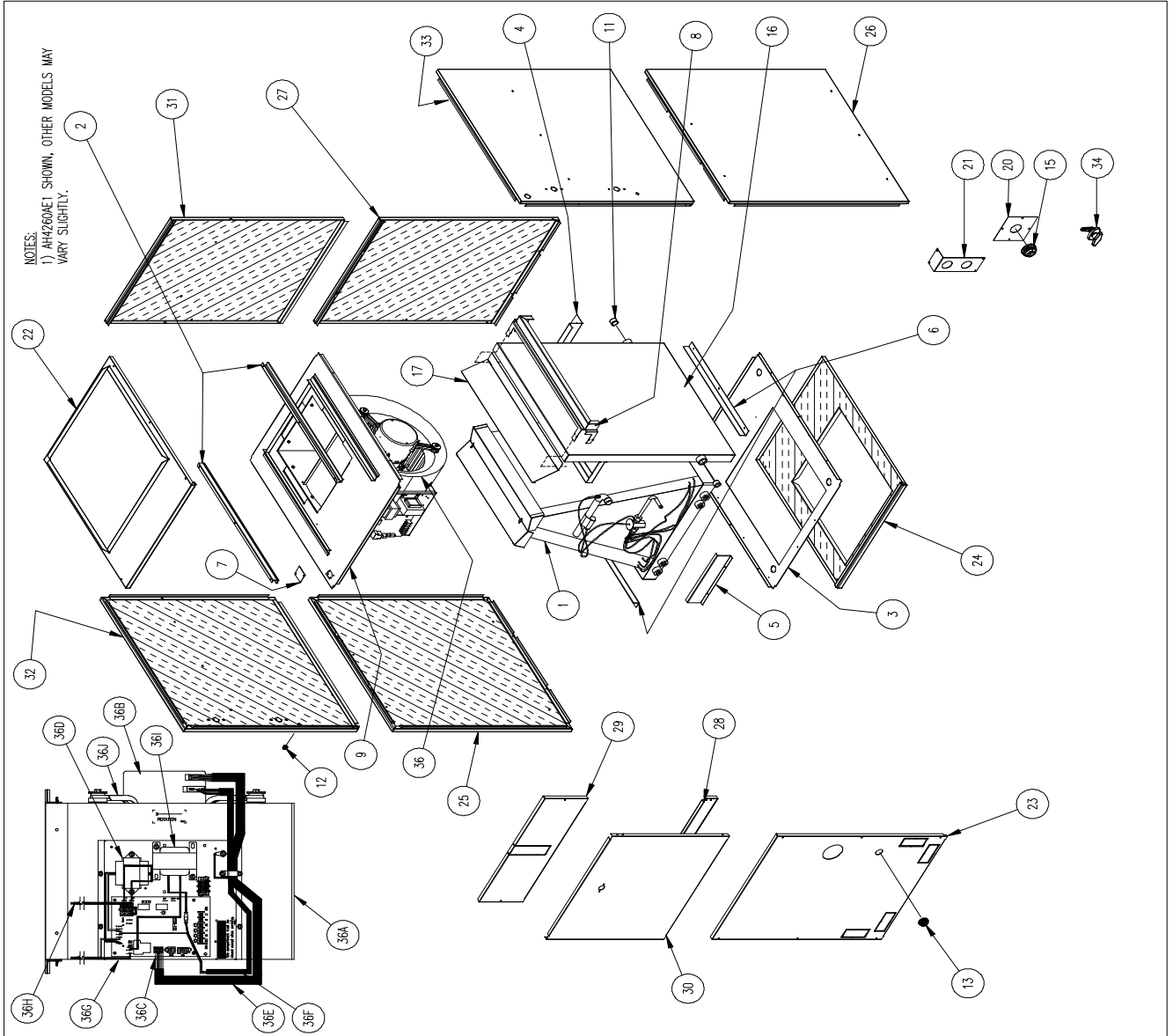

NOTES:  
 1) AH4260AET SHOWN, OTHER MODELS MAY VARY SLIGHTLY.

ITEM	PARTS DESCRIPTION	AH4260AET		AH4260BET	
		PART NO.	QTY.	PART NO.	QTY.
1	COIL, EVAPORATOR	500S8765	1	500S8765	1
2	CHANNEL, HEATING OPTION SUPPORT	18758	2	18758	2
3	PLATFORM, A-COIL	18767	1	18767	1
4	RETAINER, REAR, A-COIL DRAIN PAN	18768	1	18768	1
5	RETAINER, FRONT, A-COIL DRAIN PAN	18769	1	18769	1
6	ANGLE, SIDE SUPPORT, DRAIN PAN	18770	2	18770	2
7	COVER PLATE, EH WIRE HARNESS PASSAGE	18862	1	18862	1
8	SUPPORT, HORIZONTAL DRAIN PAN	18864	1	18864	1
9	BLOWER PAN	28774	1	28774	1
10	-	-	-	-	-
11	PLUG, THREADED PIPE 3/4 NPT	320883	2	320883	2
12	BUSHING, HEYCO 3/8	350018	1	350018	1
13	GROMMET, VINYL (SMALL)	350040	1	350040	1
14	-	-	-	-	-
15	GROMMET, VINYL (LARGE)	350063	1	350063	1
16	DRAIN PAN, HORIZONTAL	38761	1	38761	1
17	DRIP EXTENSION	12099	1	12099	1
18	-	-	-	-	-
19	-	-	-	-	-
20	TRIM PLATE	618507-1	1	618507-1	1
21	TRIM PLATE	618532-1	1	618532-1	1
22	CASING, SUPPLY AIR END	618759-1	1	618759-1	1
23	PANEL, FRONT, A-COIL ACCESS	618760-1	1	618760-1	1
24	CASING, RETURN AIR END	618763-1	1	618763-1	1
25	CASING, LEFT SIDE, COIL MODULE	618764-1	1	618764-1	1
26	CASING, RIGHT SIDE, COIL MODULE	618765-1	1	618765-1	1
27	CASING, REAR, COIL MODULE	618766-1	1	618766-1	1
28	PANEL, FRONT TIE	618771-1	1	618771-1	1
29	PANEL, FRONT, HEATING OPTION ACCESS	618772-1	1	618772-1	1
30	DOOR, BLOWER ACCESS	618773-1	1	618773-1	1
31	CASING, REAR, BLOWER MODULE	618775-1	1	618775-1	1
32	CASING, LEFT SIDE, BLOWER MODULE	618776-1	1	618776-1	1
33	CASING, RIGHT SIDE, BLOWER MODULE	618777-1	1	618777-1	1
34	DOOR HANDLE PACKAGE	AOP57578	1	AOP57578	1
35	INSTR, MANUAL AIR HANDLER	MAC-202	1	MAC-202	1
36	BLOWER SUB-ASSEMBLY	500S4498	1	500S4498	1
36A	BLOWER HOUSING ASSEMBLY	340042	1	340042	1
36B	PROGRAMMED ECM MOTOR	AOP57481	1	AOP57481	1
36C	CONTROL, ECM	AOP58381	1	350574	1
36D	TRANSFORMER	350464	1	350994	1
36E	MOTOR CONTROL WIRE HARNESS	350334	1	350334	1
36F	MOTOR POWER WIRE HARNESS	350333	1	350333	1
36G	POWER WIRE HARNESS	350929	1	-	-
36H	CIRCULATION PUMP WIRE HARNESS	350930	1	350930	1
36I	INDUCTOR	350856	1	-	-
36J	MOTOR BRACKET	AOP57670	1	AOP57670	1