



ECM OPERATION MANUAL

FOR USE WITH MODELS:

OL16-125 OL20-151
OH16-125

⚠WARNING: IF YOU DO NOT FOLLOW THE SAFETY PRECAUTIONS BELOW AND IN THIS MANUAL, A FIRE OR EXPLOSION MAY RESULT CAUSING PROPERTY DAMAGE, PERSONAL INJURY, OR LOSS OF LIFE.

DO NOT STORE OR USE GASOLINE OR OTHER FLAMMABLE VAPORS AND LIQUIDS IN THE VICINITY OF THIS OR ANY OTHER APPLIANCE.

INSTALLATION AND SERVICE MUST BE PERFORMED BY A QUALIFIED INSTALLER, SERVICE AGENCY OR THE GAS SUPPLIER. (REFERRED TO IN THESE INSTRUCTIONS AS A QUALIFIED HEATING CONTRACTOR).

PLEASE READ THESE INSTRUCTIONS PRIOR TO INSTALLATION, INITIAL FIRING, AND BEFORE PERFORMING ANY SERVICE OR MAINTENANCE. THESE INSTRUCTIONS MUST BE LEFT WITH THE HOMEOWNER AND SHOULD BE RETAINED FOR FUTURE REFERENCE BY QUALIFIED SERVICE PERSONNEL.

THERMO PRODUCTS, LLC.
BOX 237
DENTON, NC 27239
PHONE: 800-476-4328

MADE IN USA

All installations and services must be performed by qualified service personnel.

INDEX

<u>SECTION</u>	<u>BEGINNING PAG</u>
I. BLOWER CONTROL INFORMATION	1
A. TERMINAL DEFINITIONS & FIELD WIRING	1
B. WIRING & SWITCHES	2
C. INPUTS	4
D. OUTPUTS	4
E. OPERATING MODES	5
F. CFM TABLES	7
G. ECM SPECIFIC REPLACEMENT PARTS	8
III. ECM TROUBLESHOOTING	8
A. DIAGNOSTIC FEATURES	8
B. GENERAL GUIDELINES TO TROUBLESHOOTING GE ECM	9
C. TROUBLESHOOTING CHARTS	12

All installations and services must be performed by qualified service personnel.

I. BLOWER CONTROLLER INFORMATION

A. TERMINAL DEFINITIONS & FIELD WIRING

Burner Harness Connector P1

- Pin 1 – Limit switch connection.
- Pin 2 – 120 VAC Line connection.
- Pin 3 – Burner pilot contact.
- Pin 4&5 – 120 VAC Neutral connection.
- Pin 6 – Burner pilot contact.
- Pin 7&8 – From oil primary control.
- Pin 9 – Limit Switch Input (LSI).

Field Wiring to Burner

	Pilot (Tstat)	Neutral	Line
Harness Wires	Yellow Wires	White	Red
Beckett Connections	T-T terminals	White	Black
Riello Connections	T-stat terminals	White	Black

Thermostat/Humidistat connections

- "C" Common/ground
- "W" Thermostat call for heat
- "R" 24 VAC to thermostat
- "G" Thermostat call for fan
- "Y" Thermostat call for cool
- "DEHUM" Humidistat call for dehumidification (TXV systems ONLY)

Thermostat/Humidistat connections for 2-Stage control

- "C" Common/ground
- "W1" T-Stat call for heat (low fire)
- "W2" T-Stat call for heat (high fire)
- "R" 24 vac to T-Stat
- "G" T-Stat call for fan
- "Y" T-Stat call for cool
- "DEHUM" Humidistat call for dehumidification (TXV systems ONLY)

ECM control outputs

- Pin 1 - Speed Common
- Pin 2 - Speed Output
- Pin 3 – Motor CFM
- Pin 4 – Blower Enable
- Pin 5 – COOL Enable
- Pin 6 – "R" Output

Male quick connect terminals.

- "S1-3" 120 VAC Hot
- "N1-7" 120 VAC Neutral
- "EAC" Electronic Air Cleaner (120 VAC) connection.
- "HUM" Humidifier connection (120 VAC).
- "FAN" Fan On Signal
- "X" 24VAC from transformer.
- "C" 24VAC common from transformer.
- "CC" Compressor Contactor

All installations and services must be performed by qualified service personnel.

"CC_COM" Compressor Contactor Common

All installations and services must be performed by qualified service personnel.

B. WIRING & SWITCHES

OH16/OL16/20 LOWBOY

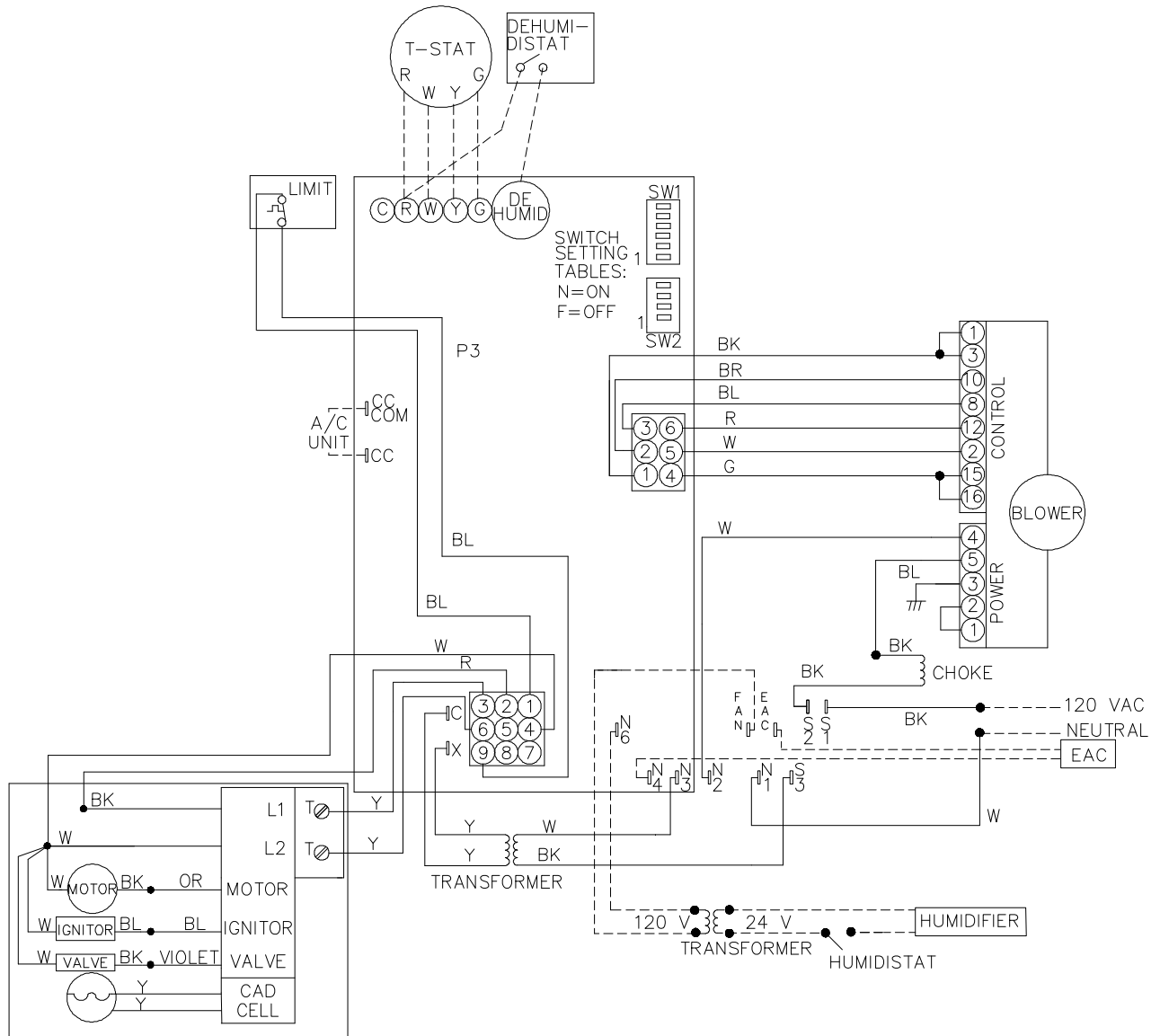

Figure 1: BLOWER WIRING

⚠WARNING: TURN OFF THE ELECTRICAL POWER to the furnace before attempting to disconnect blower wiring.

All installations and services must be performed by qualified service personnel.

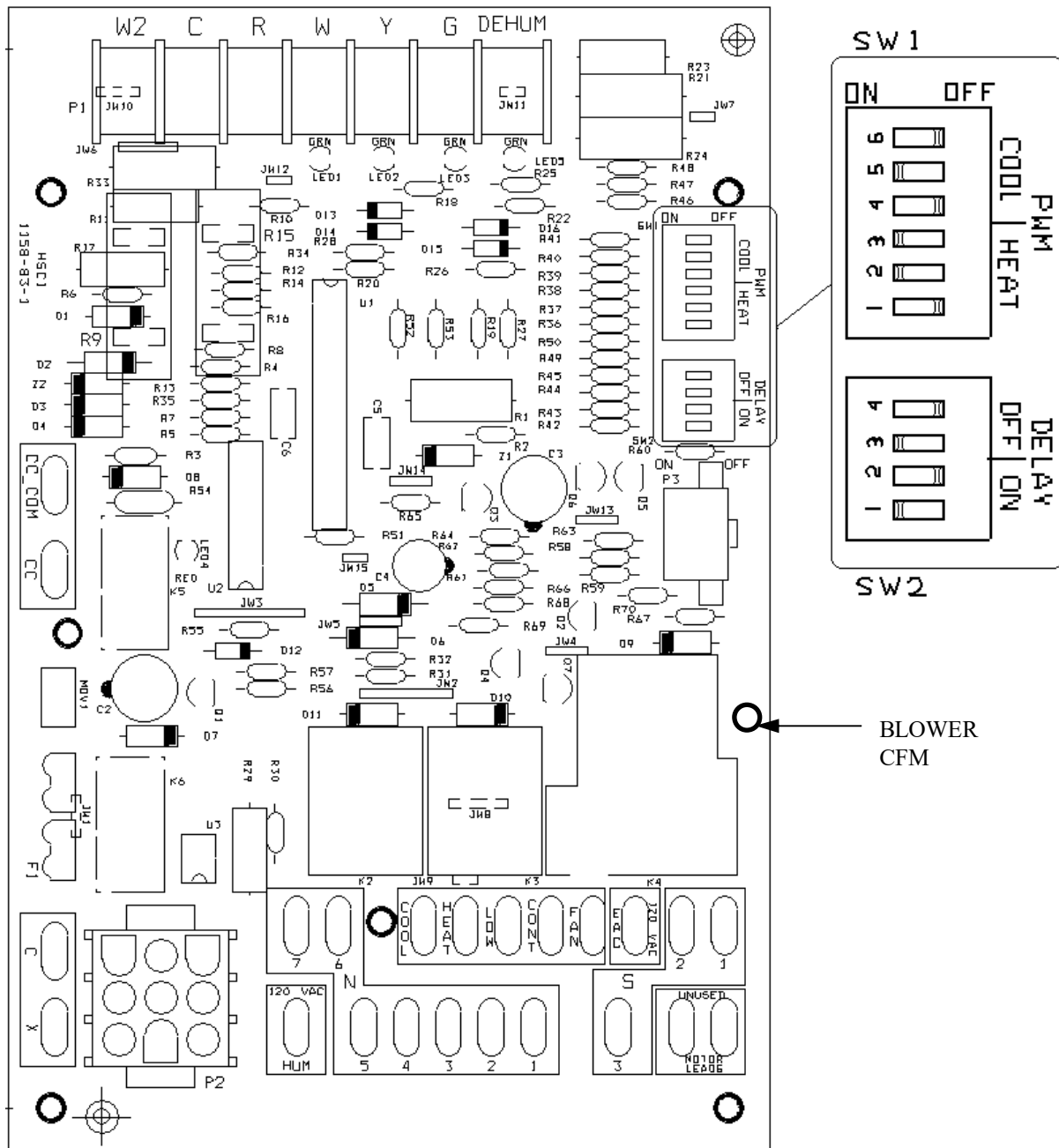

Figure 2: BOARD LAYOUT WITH SWITCHES

All installations and services must be performed by qualified service personnel.

C. Inputs

Power supplies

Line voltage is applied between the "S1" and "N1" quick connect terminals.
24 VAC Class II Transformer secondary voltage supplied to X and C

Limit Switch

The 120VAC optically isolated limit switch input is connected on pin P2-1 & 9. Refer to the Heat Mode section for the control operation.

Thermostat call for heat "W"

24 VAC thermostat input. A call for heat is recognized when the thermostat connects "W" to "R". This input has an indicator LED that will light when the control receives a call for heat. Refer to the Heat Mode section for the control operation.

Thermostat call for heat "W2"

24 VAC thermostat input. A call for heat is recognized when the thermostat connects "W2" to "R". This input has an indicator LED that will light when the control receives a call for heat. Refer to the Heat Mode section for the control operation.

Thermostat call for cool, "Y"

24 VAC thermostat input. A call for cooling is recognized when the thermostat connects "Y" to "R". This input has an indicator LED that will light when the control receives a call for cooling. . Refer to the Cool Mode section for the control operation.

Thermostat call for dehumidification "DEHUM"

24 VAC thermostat input. A call for dehumidification is recognized when the humidistat connects "DEHUM" to "R". This input has an indicator that will light when the control receives a call for dehumidification. Refer to the Cool Mode section for the control operation.

Thermostat call for fan "G"

24 VAC thermostat input. A call for fan is recognized when the thermostat connects "G" to "R". This input has an indicator LED in that will light when the control receives a call for fan. Refer to the Fan Mode section for the control operation.

D. Outputs

ECM Control

The control controls a multiple speed ECM motor through the 6-pin P3 connector. This connector provides connection for ECM Speed common (Pin 1), Speed output (Pin 2), Blower Enable (Pin 4), Cool Enable (Pin 5) and "R" output (Pin 6).

Oil Burner

Control

The control provides dedicated contacts to operate the T-T input of an oil primary control. Rating shall be class 2 - 24 VAC pilot duty @ 24 VAC (< 200mA).

Power

The switched 120VAC power from the LIMIT switch passes through the board between Pins 1&2 of connector P1.

All installations and services must be performed by qualified service personnel.

Compressor contactor

The control provides switched 24VAC to operate a compressor contactor. Rating shall be class 2 - 24 VAC pilot duty @ 24 VAC (< 200mA).

EAC (electronic air cleaner)

The control provides a 120VAC output for an electronic air cleaner. This output is energized whenever the fan motor is energized (either low, heat or cool speed). Connection is made via male quick connect terminal labeled "EAC".

Humidifier

The control provides a 120 VAC output for a humidifier. Connections are made to a male quick connect terminal labeled "FAN". The control does not switch this output, it provides a pass-through connection from P1-7 from the switched primary voltage of the Burner Module. In this application, the humidifier will operate on any blower operation. Humidifier should be controlled by humidistat to prevent operation during cooling fan operation.

Status LED

A red LED is provided to indicate any thermostat input has been recognized by the microprocessor on the control. See Diagnostic Features for a function description of operation.

Thermostat Input LEDs

Four green LEDs are placed beneath their respective thermostat connections (W, Y, G and DEHUM) and operate whenever a call is present. See Diagnostic Features for a function description of operation.

Motor CFM LED

This green LED will flash once for every 100CFM the blower is producing.

E. Operating Modes

Standby Mode

All outputs are off and the control is waiting for a thermostat demand. The thermostat inputs, and limit switch are continuously monitored. The control initiates action when a thermostat call is received or limit switch opens.

Fan Mode

A call for fan ("G") is received from the thermostat. If no other mode is calling for blower operation, the control will choose a "Low" speed value from the position of DIP switch SW1 positions 4 through 6, as shown in the CFM Tables and operate the fan at that speed. The fan mode will be operated as long as the "G" input is calling and neither the Heat mode nor the Cool mode is calling for blower operation. When the Heat and Cool modes call for blower operation, their respective outputs will take over after their respective turn-on time delays have expired. The speed Output is present until the fan call is satisfied.

Cooling Mode

A call for cool ("Y") is received from the thermostat. If the heat mode is not active or the anti-short cycle delay is not in effect, the control will energize the "CC" terminal. After a 10 second delay blower ramps up to the "COOL" speed determined by the position of DIP switch SW1 (positions 4 through 6) determine a speed as shown in CFM Tables.

When the call for cool is satisfied, the "CC" terminal is de-energized and the cooling off delay of 45 seconds is started. Forty-five seconds later the blower speed ramps toward zero and the control reverts to Standby Mode.

All installations and services must be performed by qualified service personnel.

Dehumidification Operation

If a call for dehumidification is received while the Cool Mode is active, blower speeds will be reduced. The speed value will be selected from the DEHUM column of the CFM Tables. This input may only be used on systems using a thermostatic expansion valve (TXV) on the evaporator.

Anti-Short Cycle Operation

To prevent compressor short cycling, a call for cooling will be ignored for four minutes after the termination of any cooling call. The anti-short cycle delay is also in effect at power-up.

Heat Mode

When a call for heat ("W") is received from the thermostat, if the "Cool" mode is not already active, the "T-T" terminal is energized and the blower on delay is started. The on-off pattern of DIP switch SW2 (positions 1 and 2) select one of four blowers on delay values (see Table 1). When the delay time has elapsed, a speed value is read from DIP switch SW1 positions 1 through 3 (see the CFM Tables) and the blower is ramped up to that speed. The 2-Stage control will be operated by t-stat through W1 and W2. For 2-stage control with a single stage t-stat, call for heat will go through W2. When W2 is energized, low fire is activated for 15 minutes. If a call for heat still exists, high fire will be activated and will continue until the demand for heat has been satisfied.

Counterflow units, in addition, will run at a low blower speed shortly after the burner is brought on. They will continue at that speed until the delay time has elapsed.

The control remains in steady heat mode until the thermostat is satisfied. When the call for heat signal is removed, the "T-T" terminal is de-energized and the blower off delay is started. The on-off pattern of DIP switch SW2 (positions 3 and 4) select one of four blower off delay values (see Table 1). When the delay time has elapsed, the blower is ramped toward zero.

Table 1: ON and OFF Blower Delay Time Switch Settings

DIP SWITCH 2 SECTION STATE				BLOWER DELAY TIMES		
2	1	4	3	ON - SEC	OFF - MIN	
OFF	OFF			30		
OFF	ON			60		
ON	OFF			120		Factory Set
ON	ON			240		
		OFF	OFF		2	
		OFF	ON		4	
		ON	OFF		6	Factory Set
		ON	ON		8	

Motor Blower Speed

Three blower speed outputs are provided. A "G" call for fan will provide the Low speed only. A "W" heat call will provide the Heat speed only. A "Y" cooling call will provide the Cool speed only.

In the case of thermostat calls for "Y" and "W" together, blower speed selection will be determined by the input that was first initiated. In the case where the control is in a cooling mode with both "Y" and "W" inputs energized and then the "Y" input is removed, the cooling blower off time will be executed prior to the control switching into a heating mode. In the case where the control is in a heating mode with both "Y" and "W" inputs energized and then the "W" input is removed, the heating blower off time will be executed prior to the control switching into a cooling mode. In the case where a call for fan "G" already exists and either a "W" or a "Y" call is initiated, the blower speed will switch to the respective "W" or a "Y" speed following the blower on delay for that call.

All installations and services must be performed by qualified service personnel.

Six dip switches select Speed values for heat, cool, fan and dehumidification blower speeds (see the CFM Tables).

Blower On and Off Delays

Four Heat blower on and four blower off delays are selected by two dip switches for each function. Refer to Table 1 for specific delay values.

Speed Selection values

Three dip switches select 8 cooling speeds. Dependant fan, and dehumidification speeds are selected by the same switches, their tabular values are enacted when their function is called.

Three additional dip switches select 8 heating speeds which are enacted when heat is called. This allows independent selection of heating and cooling capacity parameters. See the CFM Tables for speeds.

F. CFM TABLES

The following tables contain blower speed settings and their respective air flowrates for the ECM blower motor. To change air flowrates from that of the shipped settings, use the respective SW1 dipswitch on the furnace's integrated control board (see Figure 2).

COOLING SPEEDS

OH16/OL16

SW 1 switches	Tons	CFM		
		COOL	LOW	DEHUM
6-OFF 5-OFF 4-OFF	2.5	940	600	650
6-OFF 5-OFF 4-ON	3	1200	600	820
6-OFF 5-ON 4-OFF	3.5	1400	700	990
6-OFF 5-ON 4-ON	4	1640	820	1160
6-ON 5-OFF 4-ON	5	2000	1050	1500

HEATING SPEEDS & TEMPERATURE RISE

SW1 switches	OH16/OL16	
	°F Rise	CFM
3-ON 2-OFF 1-OFF	81	1420
3-ON 2-OFF 1-ON	74	1560
3-ON 2-ON 1-OFF	68	1710
3-ON 2-ON 1-ON	61	1900

 Factory shipped settings

All installations and services must be performed by qualified service personnel.

COOLING SPEEDS

		OL-20		
SW 1 switches	Tons	CFM		
		COOL	LOW	DEHUM
6-OFF 5-OFF 4-OFF	2.5	920	500	640
6-OFF 5-OFF 4-ON	3	1170	580	800
6-OFF 5-ON 4-OFF	3.5	1390	970	700
6-OFF 5-ON 4-ON	4	1600	800	1140
6-ON 5-OFF 4-ON	5	2070	1030	1470

HEATING SPEEDS & TEMPERATURE RISE

SW1 switches	OL20	
	°F Rise	CFM
3-ON 2-OFF 1-OFF	83	1650
3-ON 2-OFF 1-ON	76	1800
3-ON 2-ON 1-OFF	69	1980
3-ON 2-ON 1-ON	62	2200

Factory shipped settings

G. ECM SPECIFIC REPLACEMENT PARTS

Part Name	OL16	OL20	OH16
ECM Motor	AOPS7472	AOPS7473	AOPS7478
Control Board	350915	350915	350915
Motor Power Harness	350918	350918	350917
Motor Control Harness	350921	350921	350920
Burner Harness	350916	350916	350916
Transformer	350464	350464	350464
Power Choke		350856	350856

III. ECM TROUBLE SHOOTING

A. DIAGNOSTIC FEATURES

The control board is equipped with 4 green Input Status LEDs and 1 red Board Status LED. These are intended to provide a quick view into furnace performance without requiring a voltmeter.

The green Input Status LEDs are driven by the “Y”, “W”, “G”, and “DEHUM” inputs and are located directly below those inputs. They will light to indicate the presence of these signals.

The red Board Status LED has two functions:

- It will light when the board recognizes a valid input signal and will stay lit until all valid signals are removed.
- This is intended to show that the board is functioning and able to respond to input signals.

All installations and services must be performed by qualified service personnel.

It will flash rapidly while 120VAC is missing from the LIMIT switch. This is intended to give a quick visual indication of the High LIMIT switch.

B. GENERAL GUIDELINES TO TROUBLESHOOTING GE ECM – DRIVEN SYSTEMS

⚠CAUTION: Disconnect power from unit before removing or replacing connectors, or servicing motor.
Wait at least 5 minutes after disconnecting power before opening motor.

SYMPTOM	CAUSE/PROCEDURE
Motor rocks slightly when starting	<ul style="list-style-type: none"> • This is normal start-up for ECM
Motor won't start <ul style="list-style-type: none"> • No movement 	<ul style="list-style-type: none"> • Check power at motor • Check low voltage (24 VAC R to C) at motor • Check low voltage connections (G,PWM,W,R,C,) at motor • Check for unseated pins in connectors on motor harness • Test with a temporary jumper between R – G • Check motor for tight shaft • Perform motor/control replacement check • Run Moisture Check
<ul style="list-style-type: none"> • Motor rocks, but won't start 	<ul style="list-style-type: none"> • Check for loose or compliant motor mount • Make sure blower wheel is tight on shaft • Perform motor/control replacement check
Motor oscillates up & down while being tested off of blower	<ul style="list-style-type: none"> • It is normal for motor to oscillate with no load on shaft.
Motor starts, but runs erratically <ul style="list-style-type: none"> • Varies up and down or intermittent 	<ul style="list-style-type: none"> • Check line voltage for variation or “sag” • Check low voltage connections (G,PWM,W,R,C,) at motor, unseated pins in motor harness connectors • Check “Bk” for erratic CFM command (in variable speed applications) • Check-out system controls – T’stat? • Perform Moisture Check
<ul style="list-style-type: none"> • “Hunts” or “puffs” at high CFM (speed) 	<ul style="list-style-type: none"> • Does removing panel or filter reduce “puffing”? <ul style="list-style-type: none"> ➢ Reduce restriction ➢ Reduce max airflow
<ul style="list-style-type: none"> • Stays at low CFM despite system call for cool or heat CFM 	<ul style="list-style-type: none"> • Check low voltage (T’stat) wires and connections • Verify fan is not in delay mode – wait until delay complete • “R” missing/not connected at motor • Perform motor/control replacement check
<ul style="list-style-type: none"> • Stays at high CFM 	<ul style="list-style-type: none"> • “R” missing/not connected at motor • Is fan in delay mode? – wait until delay time complete • Perform motor/control replacement check
<ul style="list-style-type: none"> • Blower won't shut off 	<ul style="list-style-type: none"> • Current leakage from controls into G,Y or W? • Check for Triac switched t’stat or solid state relay

All installations and services must be performed by qualified service personnel.

Excessive noise	<ul style="list-style-type: none"> Determine if it's air noise, cabinet, duct or motor noise – interview customer, if necessary
<ul style="list-style-type: none"> Noisy blower or cabinet 	<ul style="list-style-type: none"> Check for loose blower housing, panels, etc. High static creating high blower speed? <ul style="list-style-type: none"> ➤ Check for air whistling thru seams in ducts, cabinets or panels ➤ Check for cabinet/duct deformation
<ul style="list-style-type: none"> “Hunts” or “puffs” at high CFM (speed) 	<ul style="list-style-type: none"> Does removing panel or filter reduce “puffing”? <ul style="list-style-type: none"> ➤ Reduce restriction ➤ Reduce max airflow
Evidence of Moisture	
<ul style="list-style-type: none"> Motor failure or malfunction has occurred and moisture is present 	<ul style="list-style-type: none"> Replace motor and perform Moisture Check
<ul style="list-style-type: none"> Evidence of moisture present inside air mover 	<ul style="list-style-type: none"> Perform Moisture Check

<u>DO</u>	<u>DON'T</u>
<ul style="list-style-type: none"> Check-out motor, controls, wiring and connections thoroughly before replacing motor 	<ul style="list-style-type: none"> Automatically assume the motor is bad.
<ul style="list-style-type: none"> Orient connectors down so water can't get in <ul style="list-style-type: none"> ➤ Install “drip loops” 	<ul style="list-style-type: none"> Locate connectors above 7 and 4 o'clock positions
<ul style="list-style-type: none"> Use authorized motor and control model #'s for replacement 	<ul style="list-style-type: none"> Replace one motor or control model # with another (unless an authorized replacement)
<ul style="list-style-type: none"> Keep static pressure to a minimum: <ul style="list-style-type: none"> ➤ Recommend high efficiency, low static filters ➤ Recommend keeping filters clean ➤ Design ductwork for min static, max comfort ➤ Look for and recommend ductwork improvement, where necessary, in replacement 	<ul style="list-style-type: none"> Use high pressure drop filters – some have ½” H₂O drop! Use restricted returns
<ul style="list-style-type: none"> Size the equipment wisely 	<ul style="list-style-type: none"> Oversize system then compensate with low airflow
<ul style="list-style-type: none"> Check orientation before inserting motor connectors 	<ul style="list-style-type: none"> Plug in power connector backwards Force plugs

Moisture Check

- Connectors are orientated “down” (or as recommended by equipment manufacturer)
- Arrange harnesses with “drip loop” under motor
- Is condensate drain plugged?
- Check for low airflow (too much latent capacity)
- Check for undercharged condition
- Check and plug leaks in return ducts, cabinet

Comfort Check

- Check proper airflow settings
- Low static pressure for lowest noise
- Set low continuous-fan CFM
- T'stat in bad location?

All installations and services must be performed by qualified service personnel.

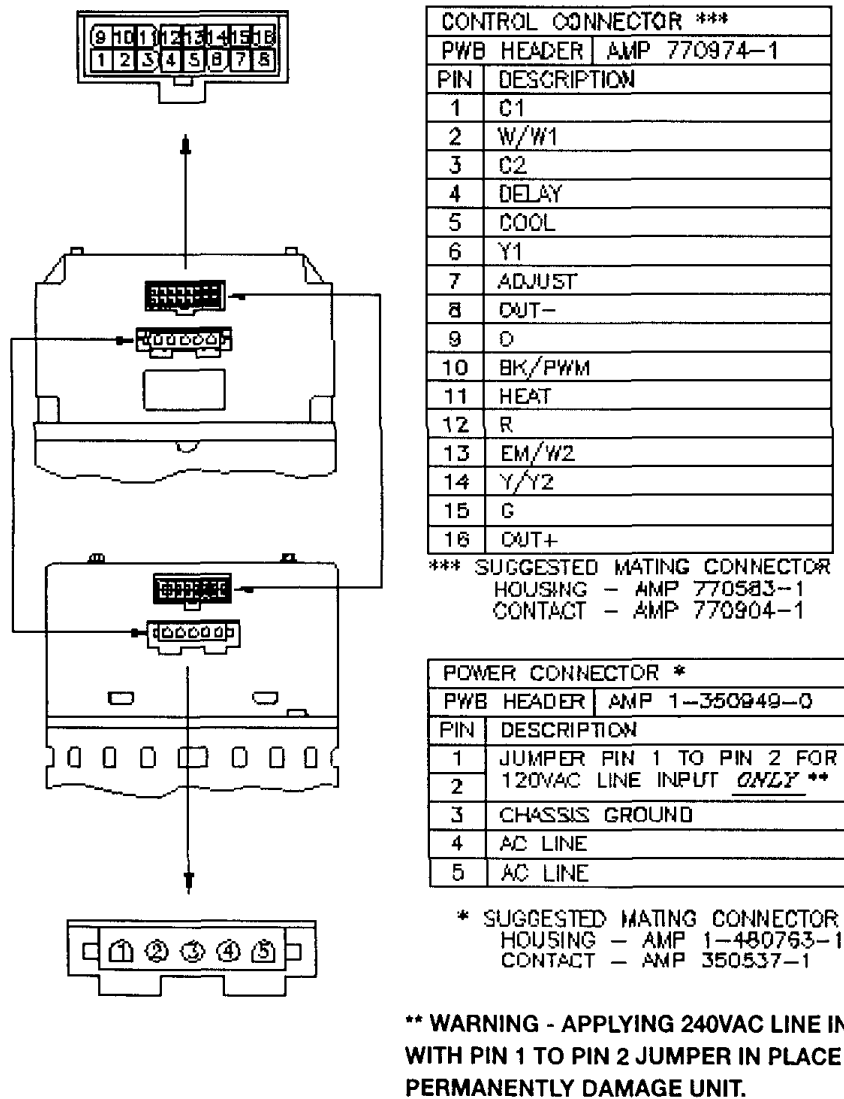

Figure 3: ECM PIN CONNECTORS

Troubleshooting table above and Figure 2 adapted from GE Industrial Systems publication GED-7161C, "Troubleshooting GE ECM - Driven Systems".

All installations and services must be performed by qualified service personnel.

C. TROUBLESHOOTING CHARTS

THIS GUIDE SHOULD BE USED IN THE CASE OF A STOPPED OR MANFUNCTIONED ECM BLOWER MOTOR. THE FOLLOWING SHOULD HELP ESTABLISH THE TYPE OF MALFUNCTION OR DEVIATION FROM THE NORMAL BLOWER OPERATION.

TO USE THIS DIAGRAM, YOU JUST NEED TO FOLLOW THE INSTRUCTIONS IN THE BOXES.

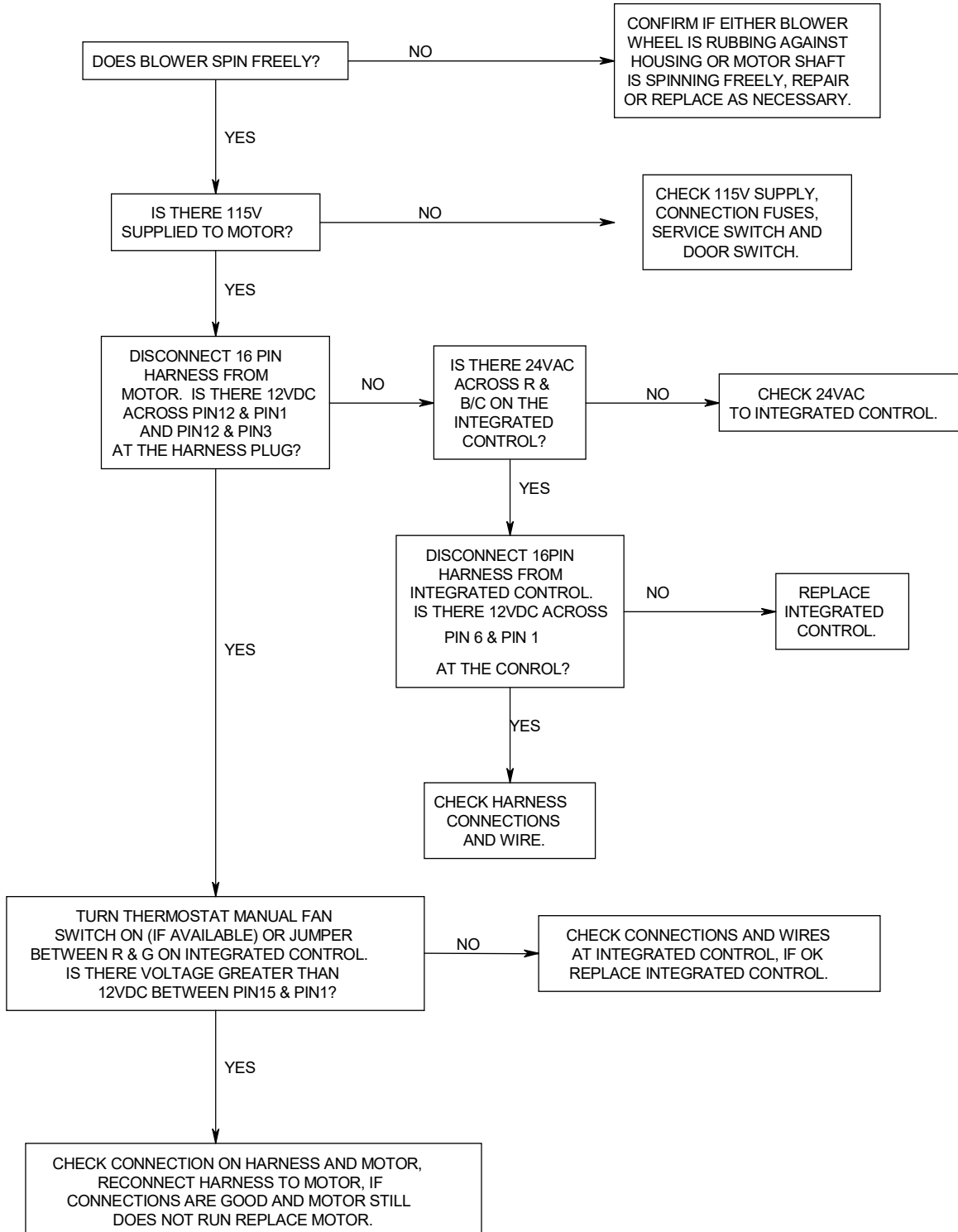

All installations and services must be performed by qualified service personnel.

Sequence of Operation

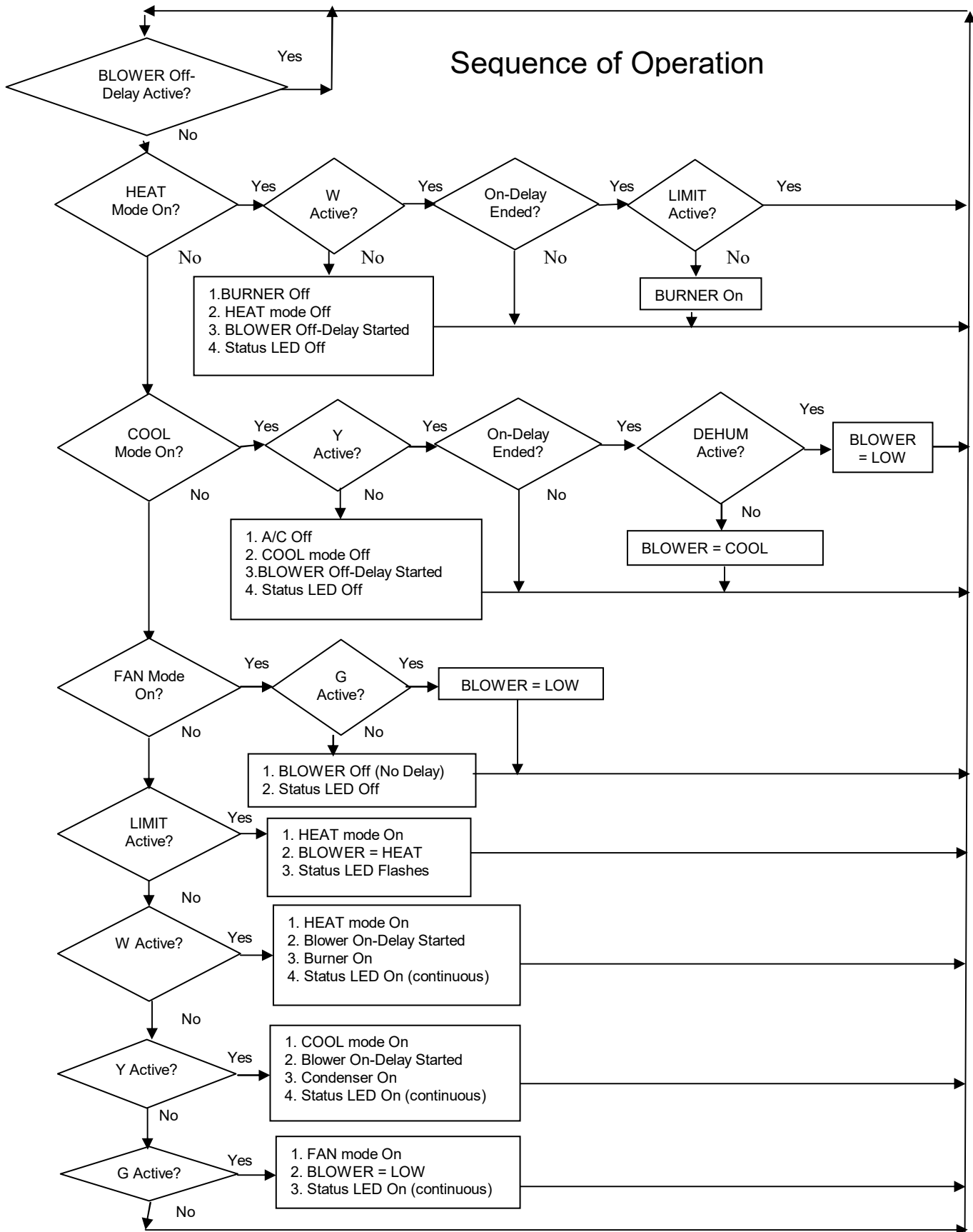

All installations and services must be performed by qualified service personnel.

Sequence of Operation Glossary

Inputs: LIMIT - 120vac power from the High Limit Switch used to power the burner.
W - Switched 24vac indicating a Heat call from the thermostat.
Y - Switched 24vac indicating a Cool call from the thermostat.
G - Switched 24vac indicating a call for blower operation from the thermostat.
DEHUM - Switched 24vac indicating a call for Dehumidification from a de-humidistat.

2 Stage Control

Inputs: LIMIT - 120vac power from the High Limit Switch used to power the burner.
W1- Switched 24vac indicating a Heat call from the thermostat. (Low fire)
W2- Switched 24vac indicating a Heat call from the thermostat. (High fire)
Y - Switched 24vac indicating a Cool call from the thermostat.
G - Switched 24vac indicating a call for blower operation from the thermostat.
DEHUM - Switched 24vac indicating a call for Dehumidification from a de-humidistat.

NOTE: 2-Stage T-stat
W1 – Low Fire
W2 – High Fire
Connect 2-Stage T-stat to both W1 and W2.
Single Stage T-stat
W2
Connect single stage T-stat to W2 only.

BLOWER Speeds:

HEAT - The Heating Blower speed selected by positions 1, 2 & 3 of SW1 (CFM tables on page 4)
COOL - The Cooling Blower speed selected by positions 4, 5 & 6 of SW1 (CFM tables on page 4)
LOW - The LOW Blower speed selected by positions 4, 5 & 6 of SW1 (CFM tables on page 4)

ECM – PSC Replacement

In an emergency situation, a defective ECM motor can be replaced with a PSC motor to provide temporary circulating air flow for heating or cooling. This is done by replacing the ECM motor in the motor mounting bracket with a PSC motor of similar Horsepower. Wire the common lead (typically white) of the replacement PSC motor to the neutral (common) terminal on the fan control board (N - 1 through 7). Connect the high-speed replacement PSC motor lead (typically black) to the EAC terminal on the fan control board. The EAC contact is energized with 115VAC any time the control board is calling for fan operation whether in heating or cooling mode. This replacement should be only used in emergency situations and only until a replacement ECM motor can be obtained and reinstalled.