

INSTALLATION MANUAL

R-410A OUTDOOR SPLIT-SYSTEM HEAT PUMP

MODELS: 13 SEER & 14.5 SEER -
THG(D,F)/GHGD/THJ(D,F)/YHJ(D,F)/YHJR/THJR SERIES
1.5 TO 5 TONS – 1 & 3 PHASE



LIST OF SECTIONS

GENERAL	1	SYSTEM CHARGE	6
SAFETY	1	ELECTRICAL CONNECTIONS	6
UNIT INSTALLATION	2	SYSTEM START-UP	8
ORIFICE INSTALLATION	5	SYSTEM OPERATION	10
TXV INSTALLATIONS	5	INSTRUCTING THE OWNER	12
EVACUATION	6	WIRING DIAGRAM	13

LIST OF FIGURES

Typical Installation with Required Clearances	2	Heat Pump Flow Diagram	9
Tubing Hanger	3	Time/Temp Control Module	9
Underground Installation	3	Demand Defrost Control Module	9
Heat Protection	4	Defrost Operation Curves	11
Orifice Installation	5	Wiring Diagram - Single Phase (Demand Defrost)	13
Outdoor Unit Control Box - Single Phase	7	Wiring Diagram - Single Phase (Time-Temp)	14
Outdoor Unit Control Box - Three Phase	7	Wiring Diagram - Three Phase (Demand Defrost)	15
Typical Field Wiring (Air Handler / Electrical Heat) (Single-Phase)	7	Wiring Diagram - Three Phase (Time-Temp)	16
Typical Field Wiring (Air Handler / Electrical Heat) - (Three Phase)	8		

LIST OF TABLES

R-410A Saturation Properties	9	X/L Output Categories	10
TEST Input Functionality	10	Defrost Initiate Curves	11

SECTION I: GENERAL

The outdoor units are designed to be connected to a matching indoor coil with sweat connect lines. Sweat connect units are factory charged with refrigerant for a matching indoor coil plus 15 feet of field supplied lines.

Matching indoor coils are available with a thermal expansion valve or an orifice liquid feed sized for the most common usage. The orifice size and/or refrigerant charge may need to be changed for some indoor-outdoor unit combinations, elevation differences, or total line lengths. Refer to Application Data covering "General Piping Recommendations and Refrigerant Line Length" (Part Number 247077).

SECTION II: SAFETY



This is a safety alert symbol. When you see this symbol on labels or in manuals, be alert to the potential for personal injury.

Understand and pay particular attention to the signal words **DANGER**, **WARNING**, or **CAUTION**.

DANGER indicates an **imminently** hazardous situation, which, if not avoided, **will result in death or serious injury**.

WARNING indicates a **potentially** hazardous situation, which, if not avoided, **could result in death or serious injury**.

CAUTION indicates a potentially hazardous situation, which, if not avoided **may result in minor or moderate injury**. It is also used to alert against unsafe practices and hazards involving only property damage.

WARNING

Improper installation may create a condition where the operation of the product could cause personal injury or property damage. Improper installation, adjustment, alteration, service, or maintenance can cause injury or property damage. Refer to this manual for assistance or for additional information, consult a qualified contractor, installer, or service agency.

CAUTION

This product must be installed in strict compliance with the enclosed installation instructions and any applicable local, state, and national codes including, but not limited to building, electrical, and mechanical codes.

INSPECTION

As soon as a unit is received, it should be inspected for possible damage during transit. If damage is evident, the extent of the damage should be noted on the carrier's delivery receipt. A separate request for inspection by the carrier's agent should be made in writing. See Local Distributor for more information.

Requirements For Installing/Serviceing R-410A Equipment

- Gauge sets, hoses, refrigerant containers, and recovery system must be designed to handle the POE type oils, and the higher pressures of R-410A.
- Manifold sets should be 800 psig high side and 250 psig low side with 550 psig low side restart.
- All hoses must have a 700 psig service pressure rating.
- Leak detectors should be designed to detect HFC refrigerant.
- Recovery equipment (including refrigerant recovery containers) must be specifically designed to handle R-410A.
- Do not use an R-22 TXV.
- A liquid-line filter drier is required on every unit.

LIMITATIONS

The unit should be installed in accordance with all National, State, and Local Safety Codes and the limitations listed below:

1. Limitations for the indoor unit, coil, and appropriate accessories must also be observed.
2. The outdoor unit must not be installed with any duct work in the air stream. The outdoor fan is the propeller type and is not designed to operate against any additional external static pressure.
3. The maximum and minimum conditions for operation must be observed to assure a system that will give maximum performance with minimum service.
4. The maximum allowable line length for this product is 75 feet.

AIR TEMPERATURE AT OUTDOOR COIL, °F				AIR TEMPERATURE AT INDOOR COIL, °F			
Min.		Max.		Min.		Max.	
DB Cool	DB Heat	DB Cool	DB Heat	WB Cool	DB Heat	WB Cool	DB Heat
50	-10	115	75	57	50 ¹	72	80

1. Operation below this temperature is permissible for a short period of time, during morning warm-up.

SECTION III: UNIT INSTALLATION

LOCATION

Before starting the installation, select and check the suitability of the location for both the indoor and outdoor unit. Observe all limitations and clearance requirements.

The outdoor unit must have sufficient clearance for air entrance to the condenser coil, for air discharge, and for service access. See Figure 1.

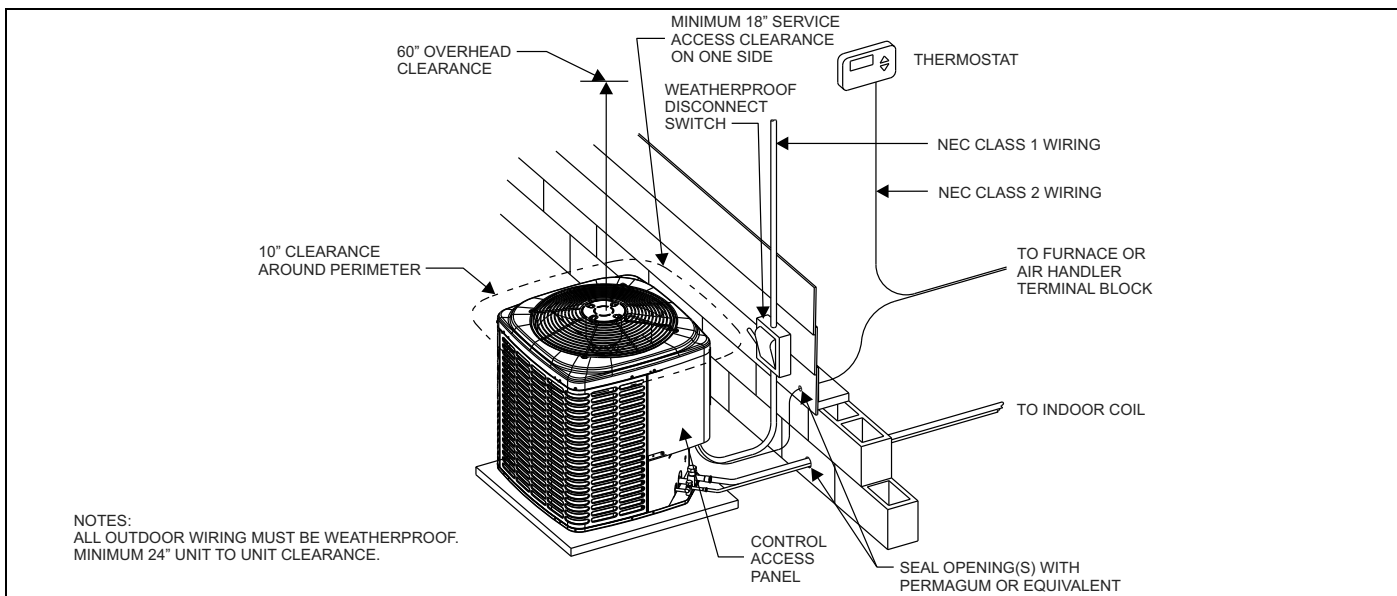

FIGURE 1: Typical Installation with Required Clearances

NOTICE

For multiple unit installations, units must be spaced a minimum of 24 inches apart (coil face to coil face).

If the unit is to be installed on a hot sun exposed roof or a black-topped ground area, the unit should be raised sufficiently above the roof or ground to avoid taking the accumulated layer of hot air into the outdoor unit.

Provide an adequate structural support.

ADD-ON REPLACEMENT/RETROFIT

When this unit is being used as a replacement for an R-22 unit, it is required that the outdoor unit, indoor coil, and metering device all be replaced. The following steps should be performed in order to insure proper system operation and performance. Line-set change out is also recommended.

1. Change-out of the indoor coil to an approved R-410A coil/ condensing unit combination with the appropriate metering device.
2. Change-out of the line-set when replacing an R-22 unit with an R410-A unit is highly recommended to reduce cross-contamination of oils and refrigerants.
3. If change-out of the line set is not practical, then the following precautions should be taken.
 - Inspect the line set for kinks, sharp bends, or other restrictions, and for corrosion.
 - Determine if there are any low spots which might be serving as oil traps.
 - Flush the line set with a commercially available flush kit to remove as much of the existing oil and contaminants as possible.
 - Install a suction line filter-drier to trap any remaining contaminants, and remove after 50 hours of operation.
4. If the outdoor unit is being replaced due to a compressor burnout, then installation of a 100% activated alumina suction-line filter drier in the suction-line is required, in addition to the factory installed liquid-line drier. Operate the system for 10 hours. Monitor the suction drier pressure drop. If the pressure drop exceeds 3 psig, replace both the suction-line and liquid-line driers. After a total of 10 hours run time where the suction-line pressure drop has not exceeded 3 psig, replace the liquid line drier, and remove the suction-line drier. Never leave a suction-line drier in the system longer than 50 hours of run time.

GROUND INSTALLATION

The unit may be installed at ground level on a solid base that will not shift or settle, causing strain on the refrigerant lines and possible leaks. Maintain the clearances shown in Figure 1 and install the unit in a level position.

Normal operating sound levels may be objectionable if the unit is placed directly under windows of certain rooms (bedrooms, study, etc.).

Condensate will drain from beneath the coil of the outdoor unit during the defrost cycle. Normally this condensate may be allowed to drain directly on the ground.

Elevate the unit sufficiently to prevent any blockage of the air entrances by snow in areas where there will be snow accumulation. Check the local weather bureau for the expected snow accumulation in your area.

Isolate the unit from rain gutters to avoid any possible wash out of the foundation.

WARNING

The outdoor unit should not be installed in an area where mud or ice could cause personal injury. Remember that condensate will drip from the unit coil during heat and defrost cycles and that this condensate will freeze when the temperature of the outdoor air is below 32°F.

ROOF INSTALLATION

When installing units on a roof, the structure must be capable of supporting the total weight of the unit, including a pad, lintels, rails, etc., which should be used to minimize the transmission of sound or vibration into the conditioned space.

UNIT PLACEMENT

1. Provide a base in the pre-determined location.
2. Remove the shipping carton and inspect for possible damage.
3. Compressor tie-down bolts should remain tightened.
4. Position the unit on the base provided.

NOTICE

Heat pumps will defrost periodically resulting in water drainage. The unit should not be located where water drainage may freeze and create a hazardous condition - such as sidewalks and steps.

LIQUID LINE FILTER-DRIER

The heat pumps have a solid core bi-flow filter/drier located on the liquid line.

NOTICE

Replacements for the liquid line drier must be exactly the same as marked on the original factory drier. See Source 1 for O.E.M. replacement driers.

CAUTION

Failure to do so or using a substitute drier or a granular type may result in damage to the equipment.

Filter-Drier Source 1 Part No.	Apply with Models
S1-52636219000	All

*As listed on the "Energy Guide yellow sticker on the unit.

PIPING CONNECTIONS

The outdoor unit must be connected to the indoor coil using field supplied refrigerant grade copper tubing that is internally clean and dry. Units should be installed only with the tubing sizes for approved system combinations as specified in Tabular Data Sheet. The charge given is applicable for total tubing lengths up to 15 feet. See Application Data Part Number 247077 for installing tubing of longer lengths and elevation differences.

NOTICE

Using a larger than specified line size could result in oil return problems. Using too small a line will result in loss of capacity and other problems caused by insufficient refrigerant flow. Slope horizontal vapor lines at least 1" every 20 feet toward the outdoor unit to facilitate proper oil return.

PRECAUTIONS DURING LINE INSTALLATION

1. Install the lines with as few bends as possible. Care must be taken not to damage the couplings or kink the tubing. Use clean hard drawn copper tubing where no appreciable amount of bending around obstruction is necessary. If soft copper must be used, care must be taken to avoid sharp bends which may cause a restriction.
2. The lines should be installed so that they will not obstruct service access to the coil, air handling system, or filter.
3. Care must also be taken to isolate the refrigerant lines to minimize noise transmission from the equipment to the structure.
4. The vapor line must be insulated with a minimum of 1/2" foam rubber insulation (Armaflex or equivalent). Liquid lines that will be exposed to direct sunlight and/or high temperatures must also be insulated.
5. Tape and suspend the refrigerant lines as shown. DO NOT allow tube metal-to-metal contact. See Figure 2.
6. Use PVC piping as a conduit for all underground installations as shown in Figure 3. Buried lines should be kept as short as possible to minimize the build up of liquid refrigerant in the vapor line during long periods of shutdown.
7. Pack fiberglass insulation and a sealing material such as permagum around refrigerant lines where they penetrate a wall to reduce vibration and to retain some flexibility.
8. See Form 247077 for additional piping information.

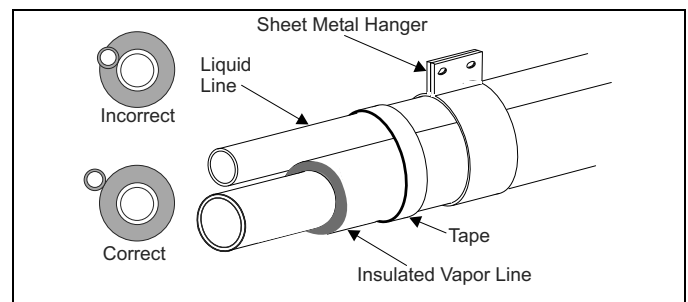

FIGURE 2: Tubing Hanger

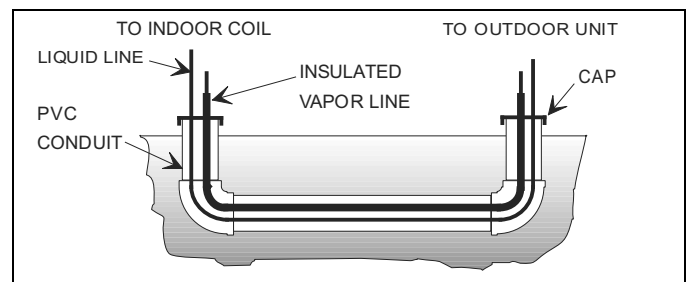

FIGURE 3: Underground Installation

PRECAUTIONS DURING BRAZING OF LINES

All outdoor unit and evaporator coil connections are copper-to-copper and should be brazed with a phosphorous-copper alloy material such as Silfos-5 or equivalent. DO NOT use soft solder. The outdoor units have reusable service valves on both the liquid and vapor connections. The total system refrigerant charge is retained within the outdoor unit during shipping and installation. The reusable service valves are provided to evacuate and charge per this instruction.

Serious service problems can be avoided by taking adequate precautions to assure an internally clean and dry system.

CAUTION

Dry nitrogen should always be supplied through the tubing while it is being brazed, because the temperature is high enough to cause oxidation of the copper unless an inert atmosphere is provided. The flow of dry nitrogen should continue until the joint has cooled. Always use a pressure regulator and safety valve to insure that only low pressure dry nitrogen is introduced into the tubing. Only a small flow is necessary to displace air and prevent oxidation.

PRECAUTIONS DURING BRAZING SERVICE VALVE

Precautions should be taken to prevent heat damage to service valve by wrapping a wet rag around it as shown in Figure 4. Also, protect all painted surfaces, insulation, and plastic base during brazing. After brazing cool joint with wet rag.

WARNING

This is not a backseating valve. The service access port has a valve core. Opening or closing valve does not close service access port. If the valve stem is backed out past the chamfered retaining wall, the O-ring can be damaged causing leakage or system pressure could force the valve stem out of the valve body possibly causing personal injury.

Valve can be opened by removing the plunger cap and fully inserting a hex wrench into the stem and backing out counter-clockwise until valve stem just touches the chamfered retaining wall.

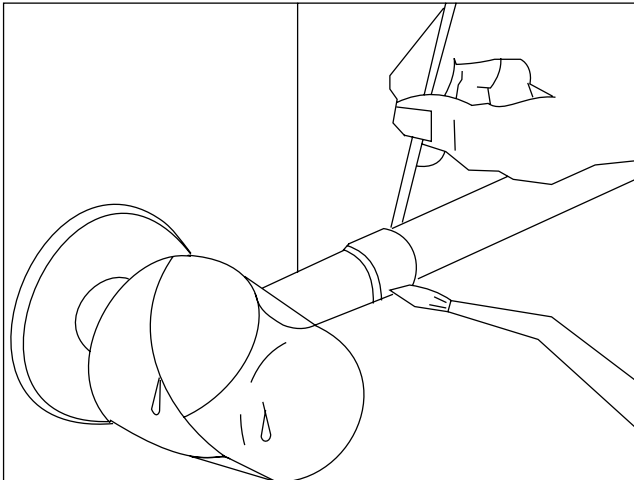

FIGURE 4: Heat Protection

Connect the refrigerant lines using the following procedure:

1. Remove the cap and Schrader core from both the liquid and vapor service valve service ports at the outdoor unit. Connect low pressure nitrogen to the liquid line service port.

2. Braze the liquid line to the liquid valve at the outdoor unit. Be sure to wrap the valve body with a wet rag. Allow the nitrogen to continue flowing. Refer to the Tabular Data Sheet for proper liquid line sizing.
3. Go to "SECTION IV" or "SECTION V" for orifice or TXV Installation depending on application.

CAUTION

Do not install any coil in a furnace which is to be operated during the heating season without attaching the refrigerant lines to the coil. The coil is under 30 to 35 psig inert gas pressure which must be released to prevent excessive pressure build-up and possible coil damage.

4. Braze the liquid line to the evaporator liquid connection. Nitrogen should be flowing through the evaporator coil.
5. Slide the grommet away from the vapor connection at the indoor coil. Braze the vapor line to the evaporator vapor connection. After the connection has cooled, slide the grommet back into original position. Refer to the Tabular Data Sheet for proper vapor line sizing.
6. Protect the vapor valve with a wet rag and braze the vapor line connection to the outdoor unit. The nitrogen flow should be exiting the system from the vapor service port connection. After this connection has cooled, remove the nitrogen source from the liquid fitting service port.
7. Replace the Schrader core in the liquid and vapor valves.
8. Leak test all refrigerant piping connections including the service port flare caps to be sure they are leak tight. DO NOT OVERTIGHTEN (between 40 and 60 inch - lbs. maximum).
9. Evacuate the vapor line, evaporator, and the liquid line to 500 microns or less.

NOTICE

Line set and indoor coil can be pressurized to 250 psig with dry nitrogen and leak tested with a bubble type leak detector. Then release the nitrogen charge.

Do not use the system refrigerant in the outdoor unit to purge or leak test.

10. Replace cap on service ports. Do not remove the flare caps from the service ports except when necessary for servicing the system.

CAUTION

Do not connect manifold gauges unless trouble is suspected. Approximately 3/4 ounce of refrigerant will be lost each time a standard manifold gauge is connected.

11. Release the refrigerant charge into the system. Open both the liquid and vapor valves by removing the plunger cap and with an allen wrench back out counter-clockwise until valve stem just touches the chamfered retaining wall. If the service valve is a ball valve, use a crescent wrench to turn valve stem one-quarter turn counterclockwise to open. Do not overturn or the valve stem may break or become damaged. See "PRECAUTIONS DURING BRAZING SERVICE VALVE".
12. Replace plunger cap finger tight, then tighten an additional 1/12 turn (1/2 hex flat). Cap must be replaced to prevent leaks.

WARNING

Never attempt to repair any brazed connections while the system is under pressure. Personal injury could result.

See "System Charge" section for checking and recording system charge.

SECTION IV: ORIFICE INSTALLATION

⚠ WARNING

Failure to install Schrader Valve Core on orifice applications could result in total refrigerant loss of the system!

Install Schrader Valve Core and Orifice as follows:

1. Relieve the holding charge by depressing the Schrader valve stem located in the end of the liquid line. Cut the spundown copper to allow installation of the suction line.
2. Slide indoor coil out of cabinet far enough to gain access to equalizer fitting on the suction line.
3. After holding charge is completely discharged remove black plastic cap on equalizer fitting.
4. Install Schrader Valve Core supplied with the outdoor unit into equalizer fitting using a valve core tool.
5. Loosen and remove the liquid line fitting from the orifice distributor assembly. Note that the fitting has right hand threads.
6. Install proper size orifice supplied with outdoor unit. Refer to supplied Tabular Data Sheet for specific orifice size and indoor coil match up.
7. After orifice is installed reinstall the liquid line to the top of the orifice distributor assembly. Hand tighten and turn an additional 1/8 turn to seal. Do not over tighten fittings.
8. Leak test system.
9. Replace black plastic cap on equalizer fitting.
10. Slide indoor coil back into cabinet.

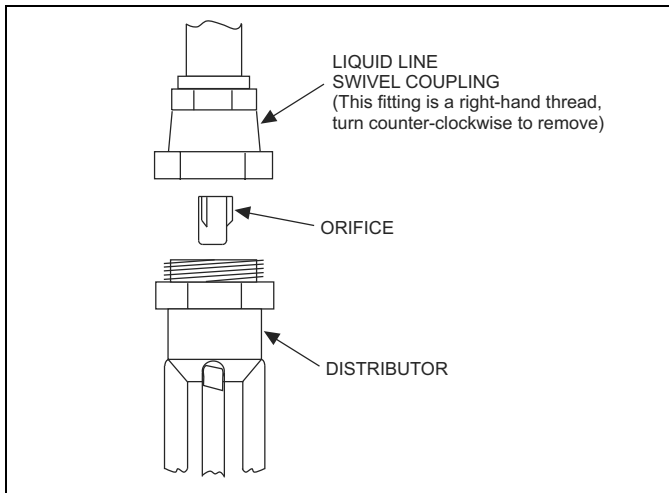

FIGURE 5: Orifice Installation

SECTION V: TXV INSTALLATIONS

For installations requiring a TXV, the following are the basic steps for installation. For detailed instructions, refer to the Installation Instructions accompanying the TXV kit.

Install TXV kit as follows:

1. Relieve the holding charge by depressing the Schrader valve stem located in the end of the liquid line. Cut the spundown copper to allow installation of the suction line.
2. After holding charge is completely discharged, loosen and remove the Schrader cap seal.

3. Loosen and remove distributor cap seal.
4. Install the thermal expansion valve to the orifice distributor assembly with supplied fittings. Hand tighten and turn an additional 1/4 turn to seal. Do not overtighten fittings.
5. Install the liquid line to the top of the thermal expansion valve with fitting supplied with the liquid line. Hand modify the liquid line to align with casing opening. Hand tighten the liquid line and an additional 1/4 turn to seal.
6. Install the TXV equalizer line into the vapor line as follows:
 - a. Hand tighten the 1/4" SAE nut to the Schrader fitting and an additional 1/3 turn to seal.
7. Install the TXV bulb to the vapor line near the equalizer line, using the bulb clamp(s) furnished with the TXV assembly. Ensure the bulb is making maximum contact.
 - a. Bulb should be installed on a horizontal run of the vapor line if possible. On lines under 7/8" O.D. the bulb may be installed on top of the line. With 7/8" O.D. and over, the bulb should be installed at the position of about 2 or 10 o'clock.
 - b. If bulb installation is made on a vertical run, the bulb should be located at least 16" (40.6 cm) from any bend, and on the tubing sides opposite the plane of the bend. The bulb should be positioned with the bulb tail at the top, so that the bulb acts as a reservoir.
 - c. Bulb should be insulated using thermal insulation provided to protect it from the effect of the surrounding ambient temperature. Cover completely to insulate from air-stream.

⚠ CAUTION

In all cases, mount the TXV bulb after vapor line is brazed and has had sufficient time to cool.

⚠ WARNING

*Schrader valve core **MUST NOT** be installed with TXV installation. Poor system performance or system failure could result.*

⚠ CAUTION

Dry nitrogen should always be supplied through the tubing while it is being brazed, because the temperature is high enough to cause oxidation of the copper unless an inert atmosphere is provided. The flow of dry nitrogen should continue until the joint has cooled. Always use a pressure regulator and safety valve to insure that only low pressure dry nitrogen is introduced into the tubing. Only a small flow is necessary to displace air and prevent oxidation.

All connections to be brazed are copper-to-copper and should be brazed with a phosphorous-copper alloy material such as Silfos-5 or equivalent. DO NOT use soft solder.

Install the TXV bulb to the vapor line near the equalizer line, using the two bulb clamps furnished with the TXV assembly. Ensure the bulb is making maximum contact. Refer to TXV installation instruction for view of bulb location.

⚠ CAUTION

In all cases, mount the TXV bulb after vapor line is brazed and has had sufficient time to cool.

SECTION VI: EVACUATION

It will be necessary to evacuate the system to 500 microns or less. If a leak is suspected, leak test with dry nitrogen to locate the leak. Repair the leak and test again.

To verify that the system has no leaks, simply close the valve to the vacuum pump suction to isolate the pump and hold the system under vacuum. Watch the micron gauge for a few minutes. If the micron gauge indicates a steady and continuous rise, it's an indication of a leak. If the gauge shows a rise, then levels off after a few minutes and remains fairly constant, it's an indication that the system is leak free but still contains moisture and may require further evacuation if the reading is above 500 microns.

SECTION VII: SYSTEM CHARGE

To ensure that your unit performs at the published levels, it is important that the indoor airflow is determined and refrigerant charge added accordingly.

Measure Indoor Air Flow:

To determine rated air flow for a specific match, consult the technical literature at www.upgnet.com.

Examples:

GHGD18S41S2 + AHE18B3XH21 = 610 CFM

THGF24S41S1+ FC35B3XN1 = 800 CFM

THJR36S41S4 + AHV36C3XH21 = 940 CFM

YHJD48S44S3 + FC60C3XN1H + TM9X100C20MP11A = 1625 CFM.

THGF60S41S1 + MC62D3XH1 + MV20DN21C = 1855 CFM(High) & 1160 (Low)

When attempting to match this air flow, select the lowest possible speed tap and measure the actual flow and adjust as necessary. Checking jumper pin setting tables is not an acceptable method for determining air flow. To determine indoor air flow, first measure the static pressure with a manometer between the filter and blower. On a single-piece air handler, take a second reading after the coil. On a furnace or modular air handler, take the second reading after the heat exchanger, but before the indoor coil. Add the negative return static to the positive supply static to determine the system total static pressure. Treat the negative return static as a positive pressure as even though it is a negative reading, it is static pressure on the blower; i.e. -.10 return static added to a .40 supply static equals a .50 total system static pressure. Compare this value the indoor unit's static pressure chart vs. CFM table or curve.

Charging the Unit:

The factory charge in the outdoor unit includes enough charge for the unit, a 15 ft. (4.6 m) line set, and the smallest indoor coil/air handler match-up. Some indoor coil/air handler matches may require additional charge. See Tabular Data Sheet provided in unit Customer Booklet for charge requirements.

The "TOTAL SYSTEM CHARGE" must be permanently marked on the unit data plate.

CAUTION

Do not leave the system open to the atmosphere.

Total system charge is determined as follows:

1. Determine outdoor unit factory charge from Tabular Data Sheet.
2. Determine indoor coil adjustment (if any) from Tabular Data Sheet.
3. Calculate the additional charge for lineset using the Tabular Data Sheet if line length is greater than 15 feet (4.6 m).
4. Total system charge = item 1 + item 2 + item 3.
5. Permanently mark the unit data plate with the total amount of refrigerant in the system.

NOTICE

This method is for systems that only have interconnecting lines. If any other objects that adjust the charge levels are placed between the indoor and outdoor units (example: a refrigerant flow meter), then before adding charge, the device must first be removed. Follow the steps above. Run the system in both cooling and heating mode and record the high side pressure in each mode. Then insert the device and charge the system by matching the same high side pressure in both heating and cooling as that value recorded without the device. It is not acceptable to add a pre-determined charge amount listed by the device manufacturer nor is it acceptable to use any other method.

WARNING

DO NOT attempt to pump "Total System Charge" into outdoor unit for maintenance, service, etc. This may cause damage to the compressor and/or other components. The outdoor unit only has enough volume for the factory charge, not the "Total System Charge".

Using the charging charts:

The unit includes heating charging charts and cooling charging charts. All units include a subcooling charging chart for cooling. If the unit can be used with an indoor orifice, then a cooling superheat chart is also included. If a charging chart is not on the unit, then it can be obtained at www.upgnet.com.

These charts should not be used to charge the unit. They are reference charts for servicing the unit. After the unit has been serviced, collect the charge and weigh it back in according to the directions.

Charging by only one method (cooling or heating), as well as charging to a superheating or subcooling value is not acceptable. Most heat pumps are sensitive to charge in one mode, so charging by only one mode can cause it under perform in the other.

Before confirming system performance against the charging charts, you should first confirm that your gauges are accurate by either comparing your gauges against a calibrated pressure gauge that has been calibrated against a national standard, or if that is not available, then place a R-410A virgin refrigerant container in a conditioned space long enough to come to temperature equilibrium with the surroundings. Then measure the temperature of the air and the pressure of the refrigerant and compare it to the following table:

Temp (°F)	Pressure (Psig)	Temp (°F)	Pressure (Psig)	Temp (°F)	Pressure (Psig)
40	119	75	218	110	365
45	130	80	236	115	391
50	143	85	255	120	418
55	156	90	274	125	447
60	170	95	295	130	477
65	185	100	317		
70	201	105	341		

If the gauges are correct, then measure the pressures using both the cooling and heating charts.

CAUTION

Refrigerant charging should only be carried out by a qualified air conditioning contractor.

CAUTION

Compressor damage will occur if system is improperly charged. On new system installations, charge system per tabular data sheet for the matched coil and follow guidelines in this instruction.

CAUTION

IT IS UNLAWFUL TO KNOWINGLY VENT, RELEASE OR DISCHARGE REFRIGERANT INTO THE OPEN AIR DURING REPAIR, SERVICE, MAINTENANCE OR THE FINAL DISPOSAL OF THIS UNIT.

SECTION VIII: ELECTRICAL CONNECTIONS

GENERAL INFORMATION & GROUNDING

Check the electrical supply to be sure that it meets the values specified on the unit nameplate and wiring label.

Power wiring, control (low voltage) wiring, disconnect switches and over current protection must be supplied by the installer. Wire size should be sized per NEC requirements.

CAUTION

All field wiring must USE COPPER CONDUCTORS ONLY and be in accordance with Local, National, Fire, Safety & Electrical Codes. This unit must be grounded with a separate ground wire in accordance with the above codes.

The complete connection diagram and schematic wiring label is located on the inside surface of the unit service access panel.

FIELD CONNECTIONS POWER WIRING

1. Install the proper size weatherproof disconnect switch outdoors and within sight of the unit.
2. Remove the screws from the control box cover and remove from unit.
3. Run power wiring from the disconnect switch to the unit.
4. Route wires from disconnect through power wiring opening provided and into the unit control box as shown in Figures 6 or 7.
5. Install the proper size time-delay fuses or circuit breaker, and make the power supply connections.

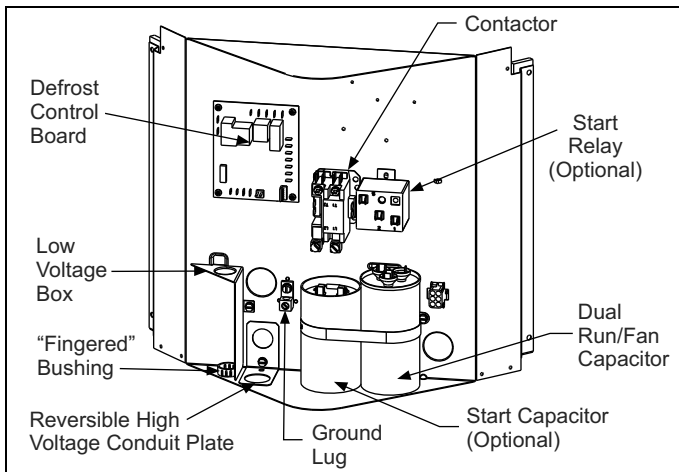

FIGURE 6: Outdoor Unit Control Box - Single Phase

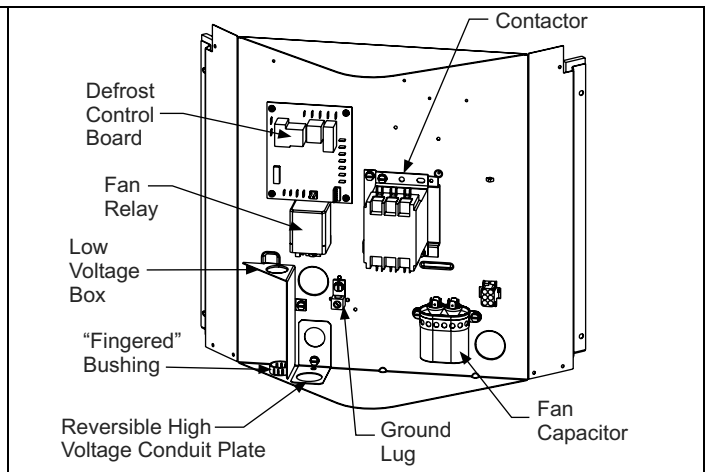

FIGURE 7: Outdoor Unit Control Box - Three Phase

FIELD CONNECTIONS CONTROL WIRING

1. Route low voltage wiring into bottom of control box as shown in Figures 6 or 7. Make low voltage wiring connections inside the low voltage box per Figures 8-9.
2. The complete connection diagram and schematic wiring label is located on the inside surface of the unit service access panel.
3. Replace the control box cover removed in Step 2.
4. All field wiring to be in accordance with national electrical codes (NEC) and/or local-city codes.
5. Mount the thermostat about 5 ft. above the floor, where it will be exposed to normal room air circulation. Do not place it on an outside wall or where it is exposed to the radiant effect from exposed glass or appliances, drafts from outside doors or supply air grilles.

6. Route the 24-volt control wiring (NEC Class 2) from the outdoor unit to the indoor unit and thermostat.

NOTICE

To eliminate erratic operation, seal the hole in the wall at the thermostat with permagum or equivalent to prevent air drafts affecting the operation of in the thermostat.

A Start Assist Kit is available and recommended for long line set applications or in areas of known low voltage problems.

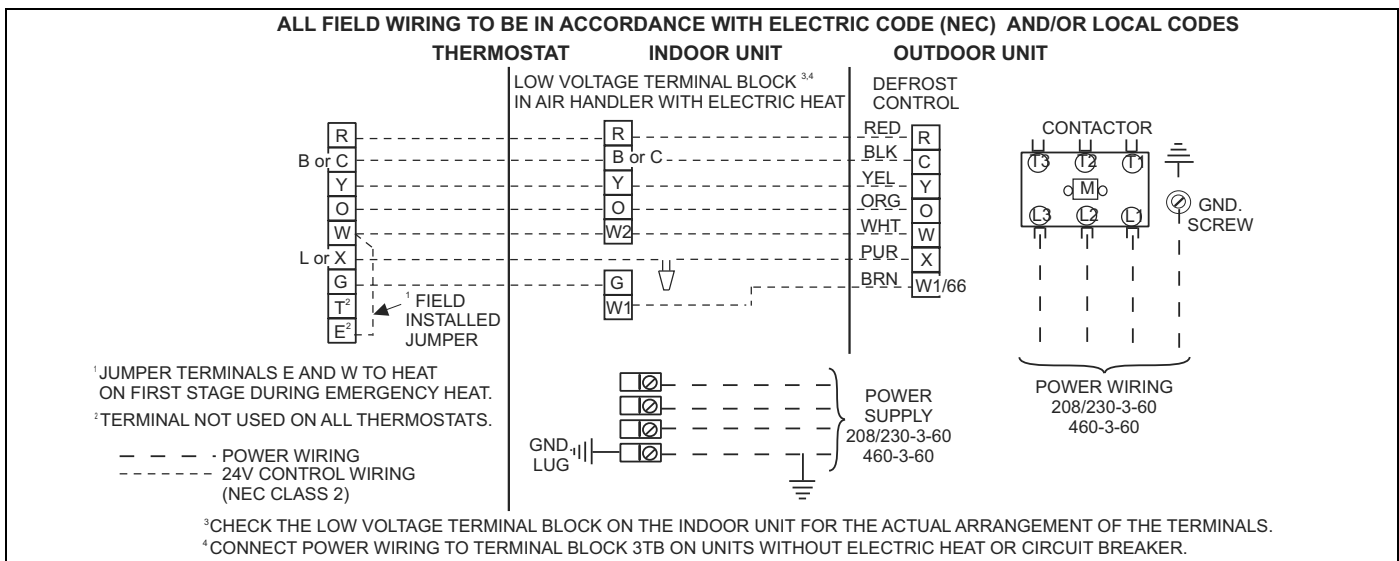

FIGURE 8: Typical Field Wiring (Air Handler / Electrical Heat) - (Three Phase)

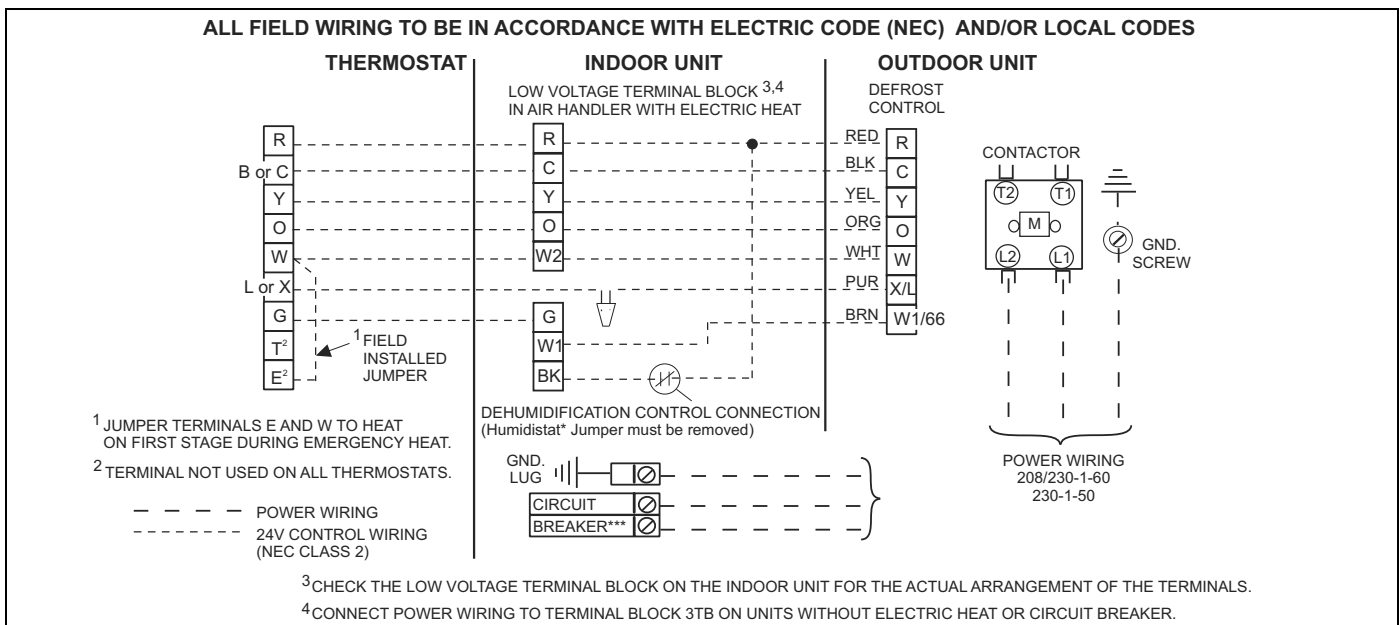

FIGURE 9: Typical Field Wiring (Air Handler / Electrical Heat) (Single-Phase)

DEHUMIDIFICATION CONTROL

A dehumidification control accessory 2HU06700124 may be used with variable speed air handlers or furnaces in high humidity areas. This control works with the variable speed indoor unit to provide cooling at a reduced air flow, lowering evaporator temperature and increasing latent heat capacity. The humidistat in this control opens the humidistat contacts on humidity rise. To install, refer to instructions packaged with the accessory. Prior to the installation of the dehumidification control, the jumper across the HUMIDISTAT terminals on the indoor variable speed air handler or furnace CFM selection board must be removed.

During cooling, if the relative humidity in the space is higher than the desired set point of the dehumidification control, the variable speed blower motor will operate at lower speed until the dehumidification control is satisfied. A 40-60% relative humidity level is recommended to achieve optimum comfort.

If a dehumidification control is installed, it is recommended that a minimum air flow of 325 cfm/ton be supplied at all times.

For connection diagrams for all UPG equipment refer to "Low Voltage System Wiring" document available online at www.upgnet.com in the Product Catalog Section.

CFM SELECTION BOARD SETTINGS

For proper system operation the CFM Selection control jumpers must be set properly.

Refer to the Tabular Data Sheet for the recommended air flow settings for each size condensing unit.

Set the cooling speed per the instructions for the air handler or furnace by selecting the correct COOL and ADJ taps. Verify the airflow using the LED display on the CFM selection board.

SECTION IX: SYSTEM START-UP

ENERGIZE CRANKCASE HEATER

If this unit is equipped with a crankcase heater for the compressor, a warning label with an adhesive back is supplied in the unit installation instruction packet. This label should be attached to the field supplied disconnect switch where it will be easily seen.

In order to energize the crankcase heater, set the indoor cooling thermostat to the OFF position. Close the line power disconnect to the unit.

IMPORTANT

An attempt to start the compressor without at least 8 hours of crankcase heat will damage the compressor.

WITH POWER TO UNIT AND THERMOSTAT IN COOLING POSITION:

1. In the cooling cycle, discharge gas is pumped to the outdoor coil which is the condenser. The indoor coil is the evaporator.
2. If fan switch is in ON position, a circuit is made through blower relay to provide continuous blower operation.
3. With fan switch in AUTO position, a circuit is made from thermostat cooling contact through blower relay to provide blower operation.
4. System will cycle with thermostat demand to provide cooling as needed.

TABLE 1: R-410A Saturation Properties

Temp °F	Pressure PSIG	Temp °F	Pressure PSIG	Temp °F	Pressure PSIG	Temp °F	Pressure PSIG	Temp °F	Pressure PSIG
45	130	60	170	75	217	90	274	105	341
46	132	61	173	76	221	91	278	106	345
47	135	62	176	77	224	92	282	107	350
48	137	63	179	78	228	93	287	108	355
49	140	64	182	79	232	94	291	109	360
50	142	65	185	80	235	95	295	110	365
51	145	66	188	81	239	96	299	111	370
52	147	67	191	82	243	97	304	112	375
53	150	68	194	83	247	98	308	113	380
54	153	69	197	84	250	99	313	114	385
55	156	70	201	85	254	100	317	115	391
56	158	71	204	86	258	101	322	116	396
57	161	72	207	87	262	102	326	117	401
58	164	73	211	88	266	103	331	118	407
59	167	74	214	89	270	104	336	119	412

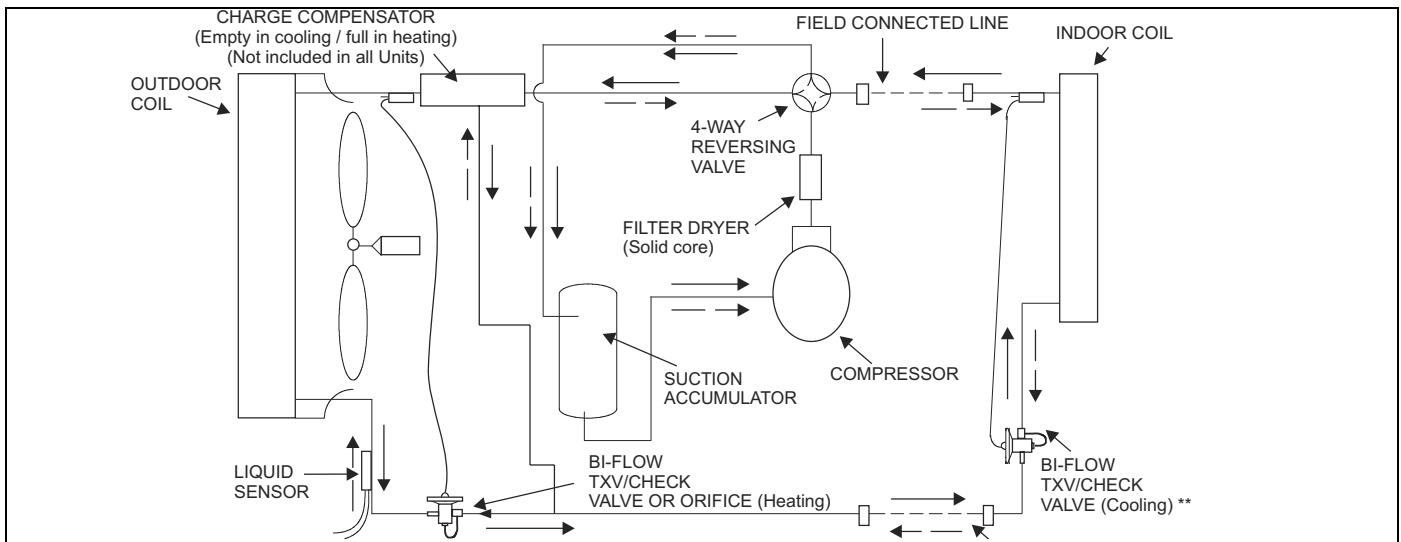

FIGURE 10: Heat Pump Flow Diagram

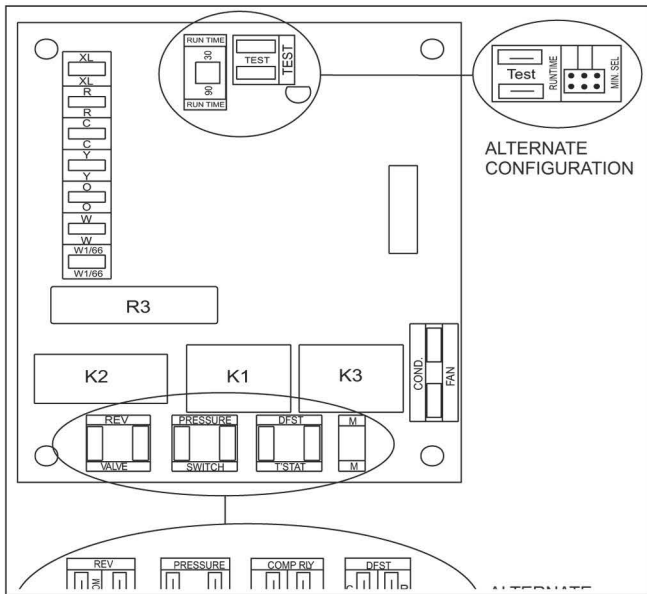

FIGURE 11: Time/Temp Control Module

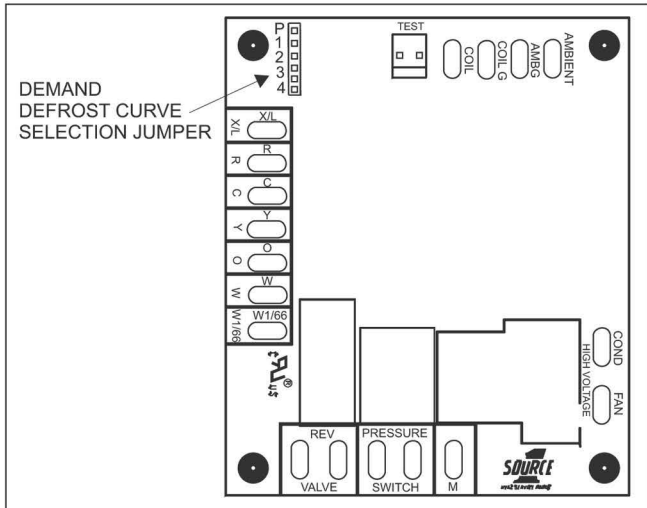

FIGURE 12: Demand Defrost Control Module

SECTION V: SYSTEM OPERATION

ANTI-SHORT CYCLE DELAY

The control includes a five-minute anti-short cycle delay (ASCD) timer to prevent the compressor from short cycling after a power or thermostat signal interruption. The ASCD timer is applied when the control is first powered from the indoor unit thermostat and immediately following the completion of a compressor run cycle. The compressor and the outdoor fan will not operate during the five minutes that the timer is active.

The ASCD timer can be bypassed by connecting the TEST terminals for three seconds while the thermostat is calling for compressor operation (Y input signal energized).

LOW VOLTAGE DETECTION

The control monitors the transformer secondary (24 VAC) voltage and provides low voltage protection for the heat pump and its components. In particular, the control prevents contactor chatter during low voltage conditions. If the voltage drops below approximately 19 VAC, the control will continue to energize any relays that are already energized but

will not energize any additional relays until the voltage level increases. If the voltage drops below approximately 16 VAC, the control will immediately de-energize the relay outputs and will not energize any relays until the voltage level increases.

TEST INPUT

The control includes a TEST input connector that can be used for various testing functions during installation and service. The TEST input connector is shown in Figures 11 & 12. The following table summarizes the behavior of the control when the two TEST pins are connected. More detailed descriptions of the various functions are included in other sections of this document.

TABLE 2: TEST Input Functionality

Duration of Connection (seconds)		Control Behavior
Time-Temp	Demand Defrost	
Less than 2	Less than 2	No response
2-9	2-6	Bypass ASCD. If Y is present and pressure switch is closed, contactors will be energized.
		Clear lockout
More than 9	More than 6	Initiate defrost cycle. (Demand only: Energize X/L with active defrost curve flash code)
Connection removed		Terminate defrost as normal
Connection not removed		Continue defrost cycle (Demand only: and X/L flash code) until TEST connection removed.

FAULT CODE DISPLAY

X/L Output

The X/L terminal of the heat pump control is typically connected to the X/L input of the room thermostat. The thermostat uses this signal to notify the homeowner of a problem with the heat pump using an LED or LCD display. When the control energizes the X/L terminal, the thermostat displays the flash code so the homeowner can see it.

TABLE 3: X/L Output Categories

Condition	X/L
Pressure Switch lockout - last mode of operation was heating	2 flashes
Pressure Switch lockout - last mode of operation was defrost	3 flashes
Incorrect Defrost Curve - jumper selection	On

When the control locks out the compressor because of a pressure switch lockout, it will energize the X/L output as shown in Table 3. The control has a three second delay between fault code flashes.

If the conditions above exist during cooling mode, the system could be in the loss of charge condition.

DEFROST OPERATION

Time/Temperature Defrost (13 Seer 2-5 Ton)

The defrost control is a time/temp. control which includes a field-selectable (tap located at board edge) time period between defrost cycle (30, 60, and 90 minutes). The jumper is factory set at 60 minutes. See Figure 13.

The electronic timer and the defrost cycle will start only when the contactor is energized and the defrost thermostat is closed. The defrost thermostat is closed when the liquid temperature falls below approximately 31° F.

The defrost mode is identical to the cooling mode except that the outdoor fan motor stops and the first stage of heat is turned on through W1 / 66 to continue warming the conditioned space.

The defrost cycle will be terminated when the defrost thermostat is opened at 55° F or 10 minutes of compressor accumulated run time, whichever comes first.

NOTICE

The defrost thermostat delay will make the coil temperature about 75-80° F. Please note that the timer will stop the circuit when R to Y is disconnected.

Demand Defrost (13 Seer 1.5 ton, 14.5 Seer 1.5-4 Ton)

The control maintains proper airflow through the outdoor coil during heating operation by melting frost and ice that may form on the coil. Frost may accumulate unevenly in different sections of the coil because of the arrangement of the refrigeration circuit within the coil. The control may initiate a defrost cycle even when the coil is not completely covered with frost. This is normal operation.

The control regulates the defrost operation of the heat pump based on accumulated compressor run time, outdoor coil temperature, and outdoor ambient temperature. The control will cause the unit to operate in the normal heating mode until it determines that a defrost cycle is needed.

All defrost timings are based on accumulated compressor run time.

Operation

The defrost mode is equivalent to the cooling mode except that the outdoor fan motor is de-energized. The control shall do the following to initiate a defrost cycle.

- De-energize the outdoor fan.
- Energize the reversing valve.
- Energize the auxiliary heat output through the W1/66 terminal.
- Begin the maximum defrost cycle length timer.

If the call for heating (Y) is removed from the control during the defrost cycle, it will terminate the defrost cycle and de-energize the compressor. The control will also stop the defrost cycle length timer but not reset it. When the control receives another call for heating, it will restart the defrost cycle and the timer at the point at which the call for heating was removed. This will happen only if the liquid line temperature conditions allow defrost to occur.

Defrost Curves

The control uses a set of defrost curve parameters that are selected using the defrost curve selection jumper. The location of the defrost curve selection jumper is shown in Figure 13. Table 4 shows the jumper position that is appropriate for each heat pump model. Jumper position 4 is not used and the control will not allow the compressor to operate when the jumper is in this position.

Defrost Curve Selection

The factory will place the defrost curve selection jumper in the P position or in a numbered position appropriate for the specific heat pump model. You should not have to change the defrost curve selection jumper during initial installation.

If the jumper is inadvertently moved, it should be placed in the appropriate numbered location based on the model number and Table 4. The control will also not energize the compressor if the defrost curve selection jumper is in a numbered position that is not described in Table 4 or if the defrost curve selection jumper is missing. The control will display the proper fault code when a defrost curve jumper error is present. The control will display the active defrost curve using the X/L terminal when the heat pump is operating in a defrost cycle that has been forced using the TEST inputs.

TABLE 4: Defrost Initiate Curves

Defrost Curve Selection Jumper Position	1	2	3	4
All Other Models	YHJR, THJR, THRD, GHRD	YHJD, YHJF, THJD, THJF, CHJD, CHJF, LHJD, LHJF, THGD, GHGD	None	None

Jumper settings 1-3 are different defrost curve settings. 4 & P will not work in application.

For instance, the X/L output will be energized with two flashes when defrost curve 2 is active. The control only reads the jumper input when the Y and W thermostat inputs are de-energized. If a jumper position is changed while either of these inputs is energized, the control will not act upon the jumper changes until the thermostat calls are de-energized or power (24 VAC) to the control is cycled.

Defrost Cycle Initiation

The control will allow the heat pump to operate in the heating mode until the combination of outdoor ambient and outdoor coil temperatures indicate that a defrost cycle is necessary.

The control will initiate a defrost cycle when the liquid line temperature is below the initiate point for the measured ambient temperature (See Figure 13) continuously for 4-1/2 minutes. This delay eliminates unnecessary defrost cycles caused by refrigeration surges such as those that occur at the start of a heating cycle.

The control will initiate a defrost cycle every 6 hours (accumulated compressor run time) to recirculate refrigerant lubricants. This forced defrost timer will be reset and restarted following the completion or termination of a defrost cycle.

The control will also initiate a defrost cycle when the TEST terminals are shorted. This feature allows an installer or service technician to start a defrost cycle immediately as required. When the TEST terminals are shorted for more than six seconds with a Y input energized and the pressure switch input is closed, the ASCD will be bypassed and the compressor and the W1/66 terminal to auxiliary heat will be energized.

When the TEST inputs are used to force a defrost cycle, the control will ignore the state of the liquid line temperature and outdoor ambient temperature inputs. The coil does not have to be cold and the outdoor temperature does not have to be within a certain range for the heat pump to be forced into a defrost cycle. After the TEST input jumper is removed, the defrost mode will be terminated as normal. The defrost cycle length timer will not be started until the TEST input is removed. If the TEST terminals remain shorted, the control will keep the unit in defrost mode.

Defrost Inhibition

The control will not initiate a defrost cycle if the liquid line temperature is above 40°F unless the defrost cycle is forced using the TEST input.

The control will also prevent a defrost cycle from being initiated too soon after the initiation of the previous defrost cycle. When power is applied to the control and after the completion or termination of each defrost cycle, the control will start a 40-minute timer. When this timer expires, the control will allow another defrost cycle when needed. The timer is based on accumulated compressor run time.

Defrost Termination

The control will terminate the defrost cycle immediately after the liquid line temperature reaches 80°F or after eight minutes of defrost operation.

The control will do the following to terminate a defrost cycle:

- Energize the outdoor fan.
- De-energize the reversing valve.
- De-energize the auxiliary heat output through the W1/66 terminal.
- Reset and restart the 40-minute defrost inhibit timer.

Compressor Delay

When Defrost Jumper Position #2 is selected the compressor is shut down for 30 seconds entering and exiting defrost mode. This delay is present in normal operation but is not present when the TEST pins are shorted to force a defrost cycle. Position #1 is recommended for reciprocating compressors, and Position #2 is recommended for scroll compressors.

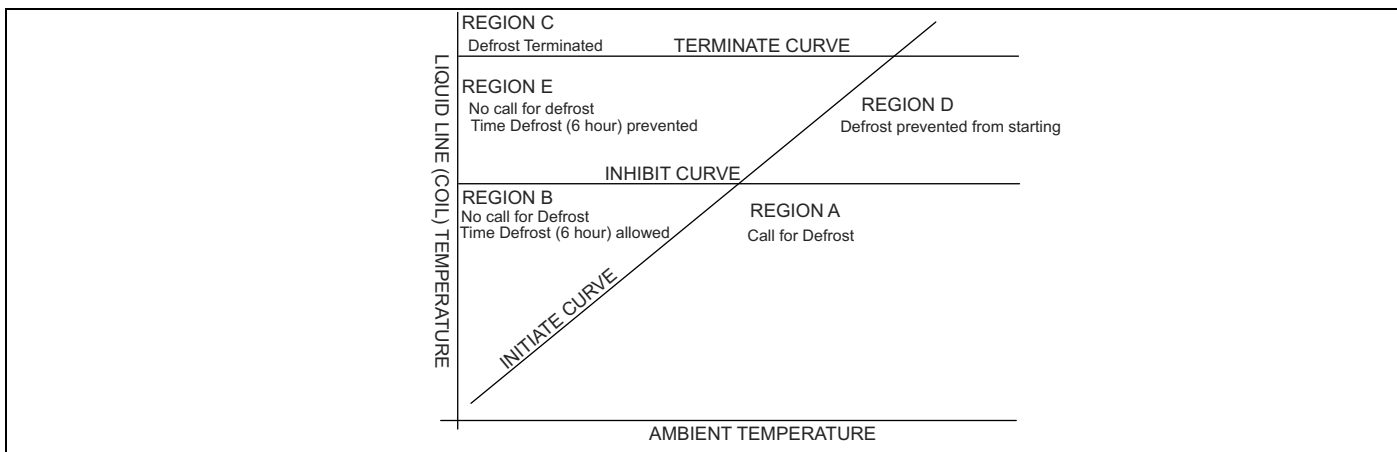

FIGURE 13: Defrost Operation Curves

COOLING OPERATION

During cooling operation, the control will receive thermostat signals at the Y and O input terminals. The control will energize the M compressor output terminal. This signal energizes the coil of the compressor contactor causing the compressor to run. The control also delivers power to the COND FAN terminals causing the outdoor fan to operate. The control energizes the REV VALVE terminal with 24VAC to switch the reversing valve.

HEATING OPERATION

During normal heating mode, the control will receive a thermostat signal at the Y input terminal. The control will energize the M compressor output terminal. This signal energizes the coil of the compressor contactor causing the compressor to run. The control also delivers power to the COND FAN terminals causing the outdoor fan to operate. The reversing valve is not energized in heating mode.

EMERGENCY HEAT

When the thermostat calls for emergency heat operation (W signal without a Y signal), the control will de-energize the compressor and energize the W1/66 terminal immediately.

PRESSURE SWITCH FAULT & LOCKOUT

The heat pump is equipped with a pressure switch, loss of charge switch and an over temp switch (units equipped with scroll compressor) that are connected to the control at the pressure switch terminals. If one of these switches input opens for more than 40 milliseconds, the control will de-energize the compressor. If the switch closes and a thermostat call for compressor operation is present, the control will apply the five-minute anti-short cycle delay timer and start the compressor when the timer expires.

When the compressor is started following a switch fault, the control will start a six-hour timer based on accumulated compressor run time. If the control senses another opening of the switch before the timer expires, it will cause a soft lockout condition. The second opening of the switch must be greater than 160 milliseconds for the lockout to occur. If the second opening is between 40 and 160 milliseconds, the control will de-energize the compressor but not cause a soft lockout condition. If the control does not sense a second switch opening before the six-hour timer expires, the timer and counter will be reset.

During the soft lockout mode, the control will de-energize the compressor and energize the X/L output with the appropriate flash code.

The control will reset the soft lockout condition when any of the following occur following removal of the fault condition.

1. Power is cycled to the R or Y inputs of the control. This will cause the soft lockout condition to be reset when the thermostat is satisfied or when the thermostat is set to SYSTEM OFF and back to HEAT or COOL mode.

2. The TEST terminals are shorted for more than two seconds.

When the soft lockout condition is reset, the control will stop displaying the fault code and will respond to thermostat inputs normally.

SECTION VI: INSTRUCTING THE OWNER

Assist owner with processing warranty cards and/or online registration. Review Owners Guide and provide a copy to the owner and guidance on proper operation and maintenance. Instruct the owner or the operator how to start, stop and adjust temperature setting.

When applicable, instruct the owner that the compressor is equipped with a crankcase heater to prevent the migration of refrigerant to the compressor during the OFF cycle. The heater is energized only when the unit is not running. If the main switch is disconnected for long periods of shut down, do not attempt to start the unit until 8 hours after the switch has been connected. This will allow sufficient time for all liquid refrigerant to be driven out of the compressor.

The installer should also instruct the owner on proper operation and maintenance of all other system components.

MAINTENANCE

1. Dirt should not be allowed to accumulate on the outdoor coils or other parts in the air circuit. Clean as often as necessary to keep the unit clean. Use a brush, vacuum cleaner attachment, or other suitable means.
2. The outdoor fan motor is permanently lubricated and does not require periodic oiling.
3. If the coil needs to be cleaned, it should be washed with Calgon Coilclean (mix one part Coilclean to seven parts water). Allow solution to remain on coil for 30 minutes before rinsing with clean water. Solution should not be permitted to come in contact with painted surfaces.
4. Refer to the furnace or air handler instructions for filter and blower motor maintenance.
5. The indoor coil and drain pan should be inspected and cleaned regularly to prevent odors and assure proper drainage.

CAUTION

IT IS UNLAWFUL TO KNOWINGLY VENT, RELEASE OR DISCHARGE REFRIGERANT INTO THE OPEN AIR DURING REPAIR, SERVICE, MAINTENANCE OR THE FINAL DISPOSAL OF THIS UNIT.

SUBCOOLING CHARGE TABLE IS ON THE UNIT RATING PLATE.

SECTION VII: WIRING DIAGRAM

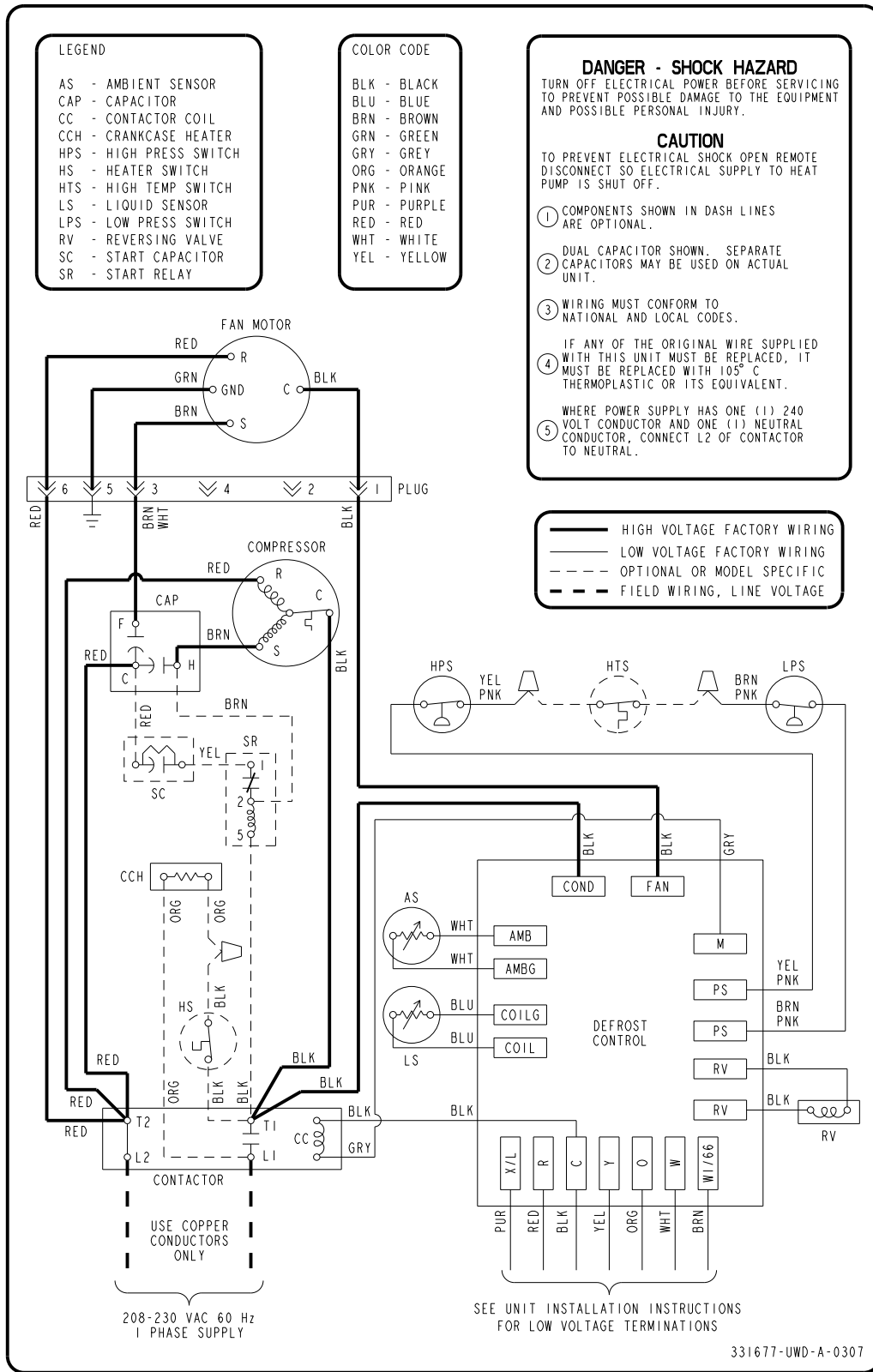

FIGURE 14: Wiring Diagram - Single Phase (Demand Defrost)

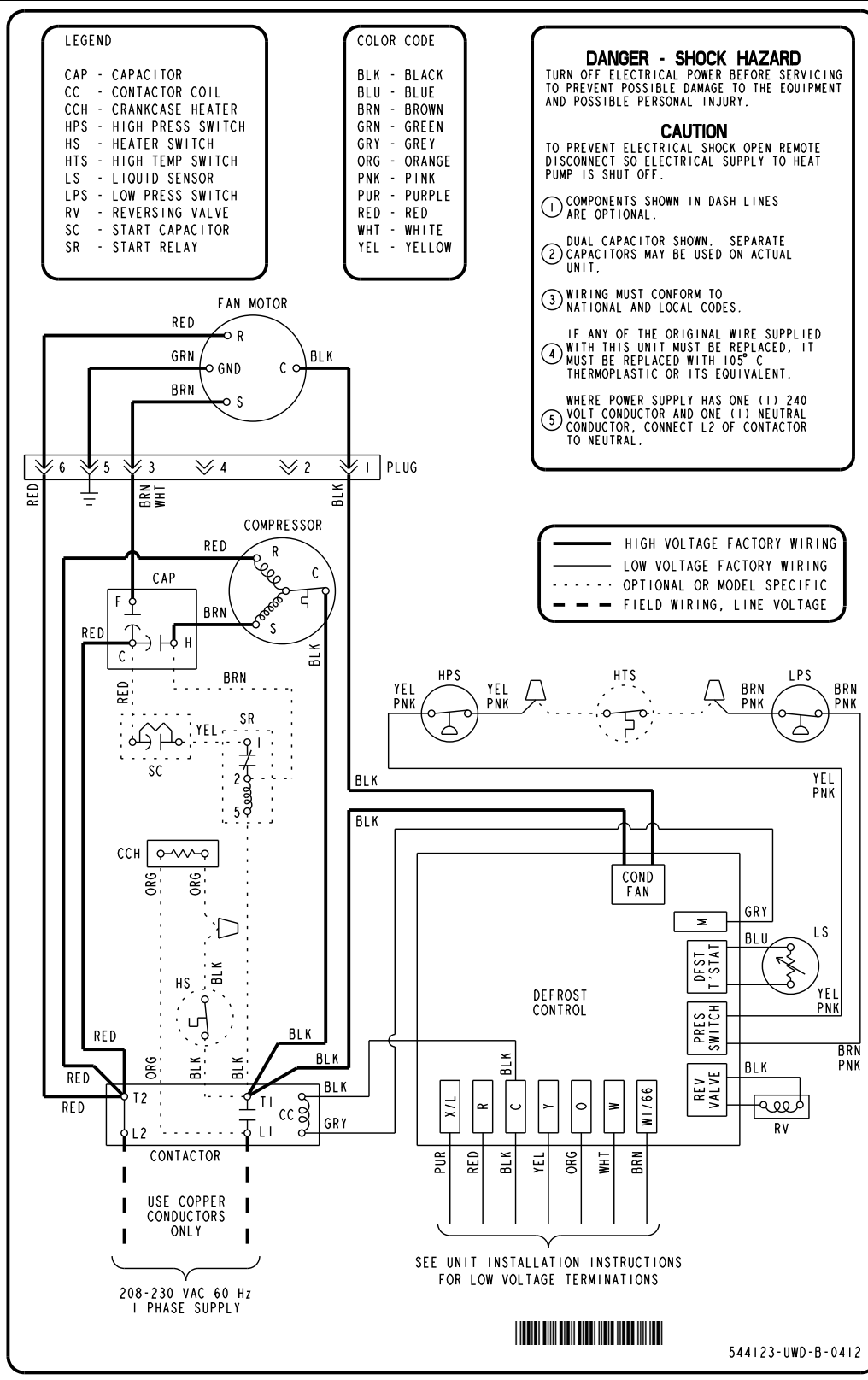

FIGURE 15: Wiring Diagram - Single Phase (Time-Temp)

LEGEND

AS - AMBIENT SENSOR
 CAP - CAPACITOR
 CC - CONTACTOR COIL
 CCH - CRANKCASE HEATER
 HPS - HIGH PRESS SWITCH
 HS - HEATER SWITCH
 LS - LIQUID SENSOR
 LPS - LOW PRESS SWITCH
 RV - REVERSING VALVE
 SC - START CAPACITOR
 SR - START RELAY

COLOR CODE

BLK - BLACK
 BLU - BLUE
 BRN - BROWN
 BR/WH - BROWN/WHITE
 GRN - GREEN
 GRY - GREY
 ORG - ORANGE
 PUR - PURPLE
 RED - RED
 WHT - WHITE
 YEL - YELLOW

DANGER - SHOCK HAZARD
 TURN OFF ELECTRICAL POWER BEFORE SERVICING TO PREVENT POSSIBLE DAMAGE TO THE EQUIPMENT AND POSSIBLE PERSONAL INJURY.

CAUTION
 TO PREVENT ELECTRICAL SHOCK OPEN REMOTE DISCONNECT SO ELECTRICAL SUPPLY TO HEAT PUMP IS SHUT OFF.

1 COMPONENTS SHOWN IN DASH LINES ARE OPTIONAL.
 2 WIRING MUST CONFORM TO NATIONAL AND LOCAL CODES.
 3 IF ANY OF THE ORIGINAL WIRE SUPPLIED WITH THIS UNIT MUST BE REPLACED, IT MUST BE REPLACED WITH 105° C THERMOPLASTIC OR ITS EQUIVALENT.
 4 WHERE POWER SUPPLY HAS ONE (1) 240 VOLT CONDUCTOR AND ONE (1) NEUTRAL CONDUCTOR, CONNECT L2 OF CONTACTOR TO NEUTRAL.
 5 FAN RELAY AND WIRES LABELED 460V ONLY USED ON 380/415V OR 460V

— HIGH VOLTAGE FACTORY WIRING
 — LOW VOLTAGE FACTORY WIRING
 - - - - - OPTIONAL WIRING
 - - - - - FIELD WIRING, LINE VOLTAGE
 ····· 460V FAN RELAY WIRING

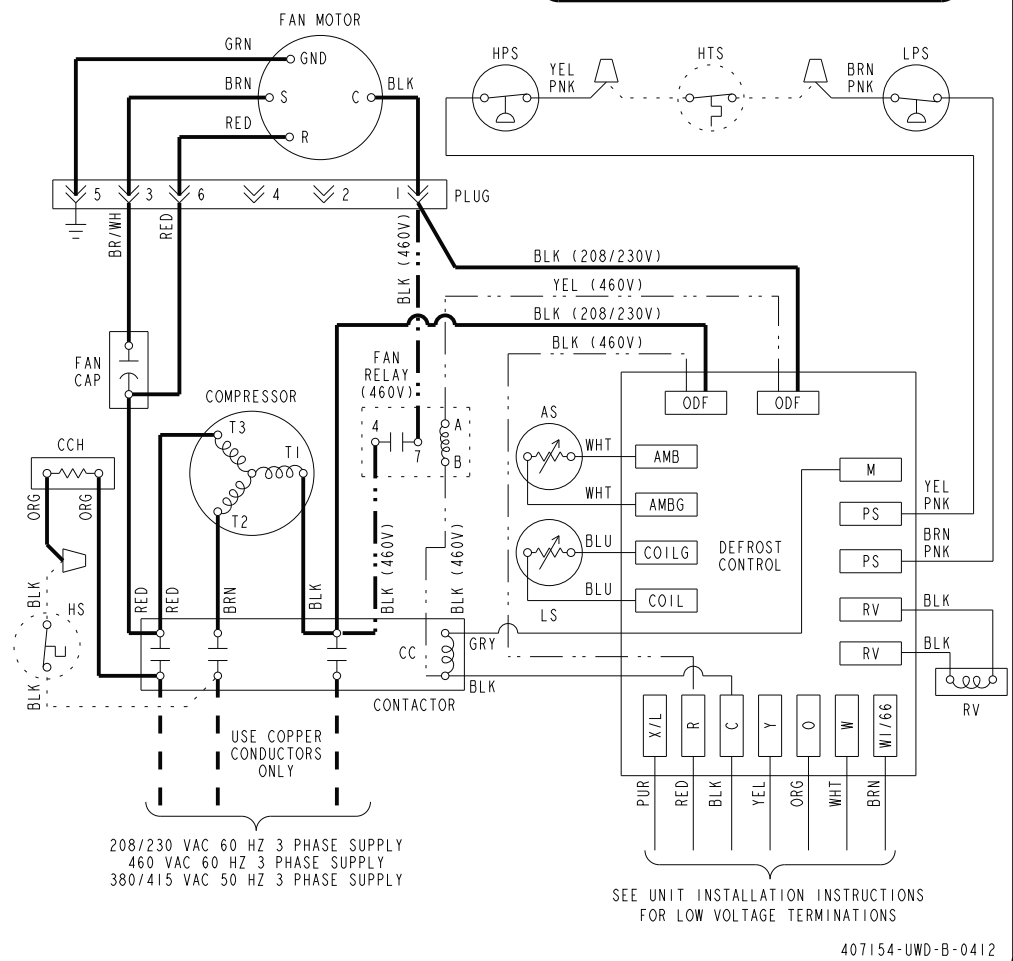

FIGURE 16: Wiring Diagram - Three Phase (Demand Defrost)

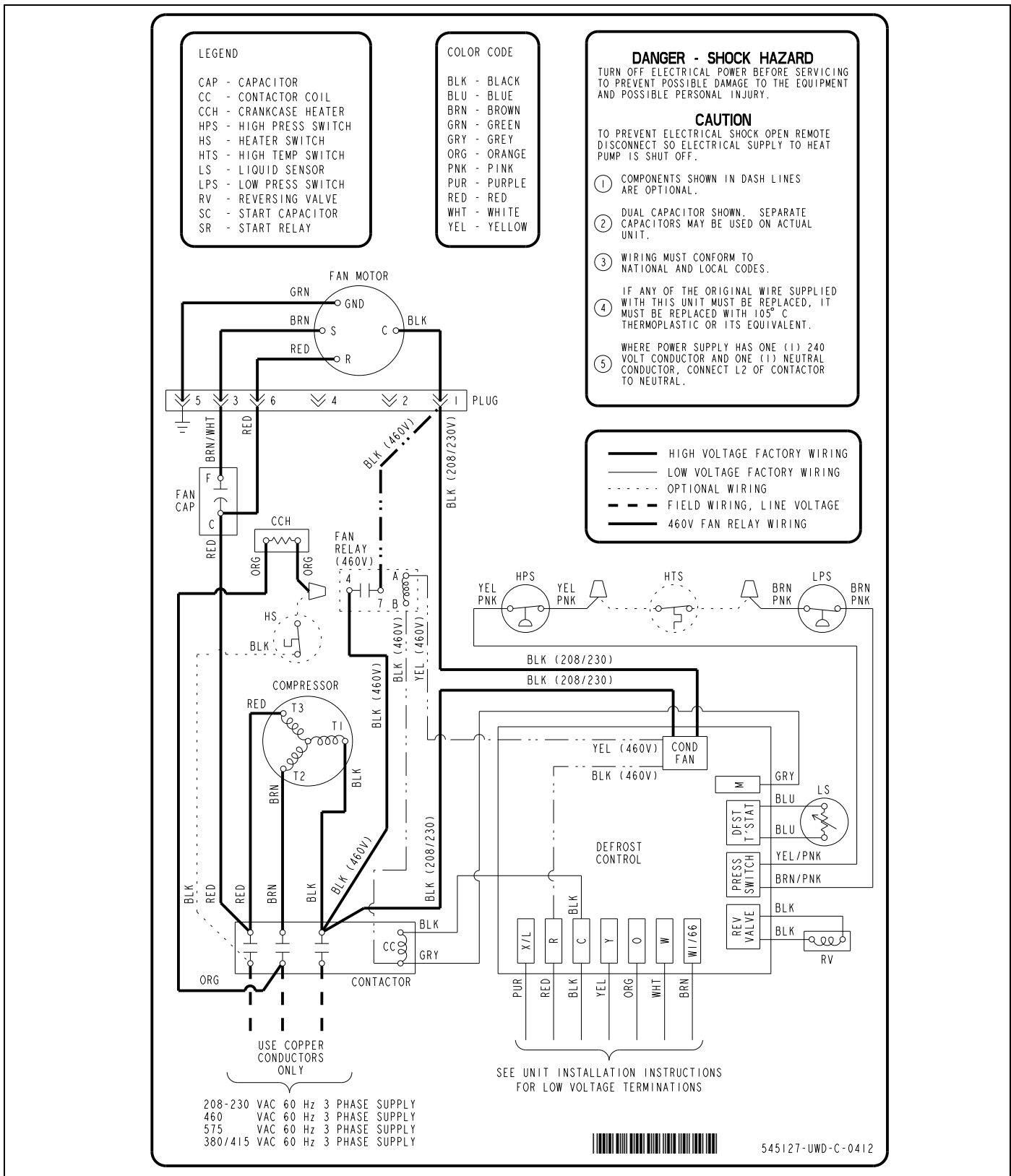

FIGURE 17: Wiring Diagram - Three Phase (Time-Temp)